



TOYOTA A540E

INDEX

GENERAL DESCRIPTION	3
GENERAL TROUBLE-SHOOTING	9
COMPONENT APPLICATION CHART	11
WIRING SCHEMATIC	16
EXPLODED TRANSAXLE VIEWS	18
TRANSAXLE DISASSEMBLY	22
COMPONENT INSPECTION AND ASSEMBLY	35
VALVE BODY INSPECTION AND ASSEMBLY	61
FINAL DRIVE INSPECTION AND ASSEMBLY	71
TRANSAXLE ASSEMBLY	80
CHECK BALL LOCATIONS	96
CHECKING TRANSAXLE FREEWHEELS	99
UPDATED COMMON SUMP CASE DIFFERENCES	102
HIGH OR LOW LINE PRESSURE CONCERNS	106

AUTOMATIC TRANSMISSION SERVICE GROUP
18639 SW 107TH AVENUE
MIAMI, FLORIDA 33157
(305) 670-4161



*Updated
January, 2004*

INTRODUCTION TOYOTA A540E

The Toyota A540E is an automatic overdrive transaxle that is found in the V-6 Camery model vehicles. It is an electronic controlled transaxle and very similar to the A140. We have included a section on the basic operation, diagnosis, disassembly, reassembly of this unit along with a section on some of the updates and changes that have occurred.

*We wish to thank Toyota
for the information and illustrations
that have made this booklet possible.*

No part of any ATSG publication may be reproduced, stored in any retrieval system or transmitted in any form or by any means, including but not limited to electronic, mechanical, photocopying, recording or otherwise, without *written* permission of Automatic Transmission Service Group. This includes all text illustrations, tables and charts.

*The information and part numbers contained in this booklet have
been carefully compiled from industry sources known for their
reliability, but ATSG does not guarantee its accuracy.*

Copyright © ATSG 2003

DALE ENGLAND
FIELD SERVICE CONSULTANT

WAYNE COLONNA
TECHNICAL SUPERVISOR

PETER LUBAN
TECHNICAL CONSULTANT

JON GLATSTEIN
TECHNICAL CONSULTANT

ROLAND ALVAREZ
TECHNICAL CONSULTANT

GERALD CAMPBELL
TECHNICAL CONSULTANT

JIM DIAL
TECHNICAL CONSULTANT

ED KRUSE
TECHNICAL CONSULTANT

GREGORY LIPNICK
TECHNICAL CONSULTANT

DAVID CHALKER
TECHNICAL CONSULTANT

JERRY GOTT
TECHNICAL CONSULTANT

MIKE SOUZA
TECHNICAL CONSULTANT

AUTOMATIC TRANSMISSION SERVICE GROUP
18639 SW 107TH AVENUE
MIAMI, FLORIDA 33157
(305) 670-4161



DESCRIPTION

GENERAL

The A540E is a 4-speed, Electronic Controlled Transaxle (hereafter called ECT) developed exclusively for use with a transversely-mounted engine. A lock-up is built into the torque converter.

The A540E transaxle is mainly composed of the torque converter, the 4-speed planetary gear unit, the differential, the hydraulic control system and the electronic control system.

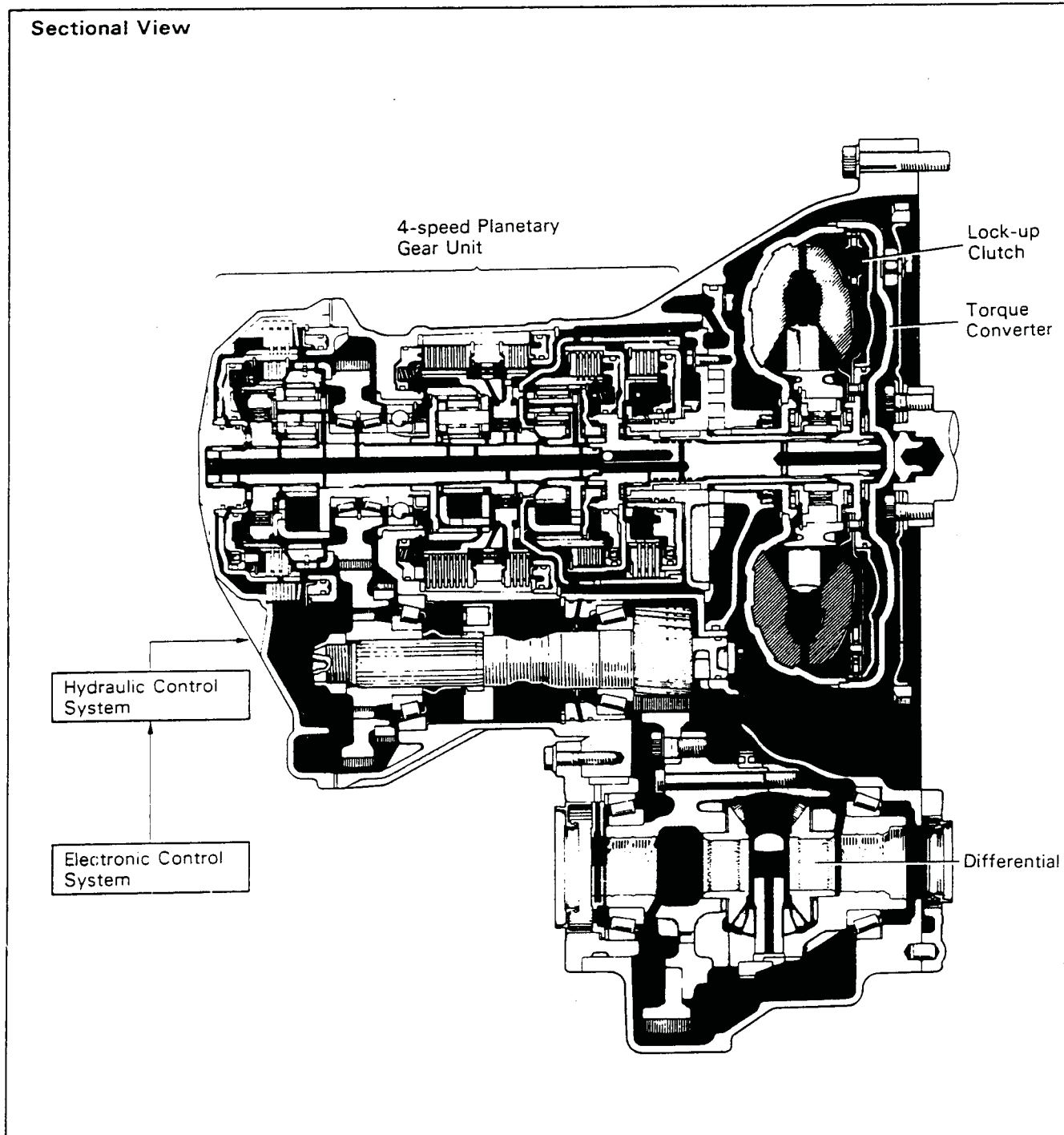



Technical Service Information

OUTLINE OF ECT

The conventional automatic transmission operates by mechanically converting vehicle speed into governor pressure, and throttle opening into throttle pressure, and using these hydraulic pressures to control the operation of the clutches and brakes in the planetary gear unit, thus controlling the timing of up-shift and down-shift of the transmission. This is called the "hydraulic control method."

In the case of the ECT, on the other hand, sensors electronically sense the speed of the vehicle and the throttle opening and send this information to the electronic controlled unit (hereafter called ECU) in the form of electrical signals. The ECU then controls the operation of the clutches and brakes based on these data, thus controlling the timing of the shift points.

SHIFT CONTROL

• Hydraulic Controlled Transmission

Shifting in the fully hydraulic controlled automatic transmission is carried out by the hydraulic control unit in the following way:

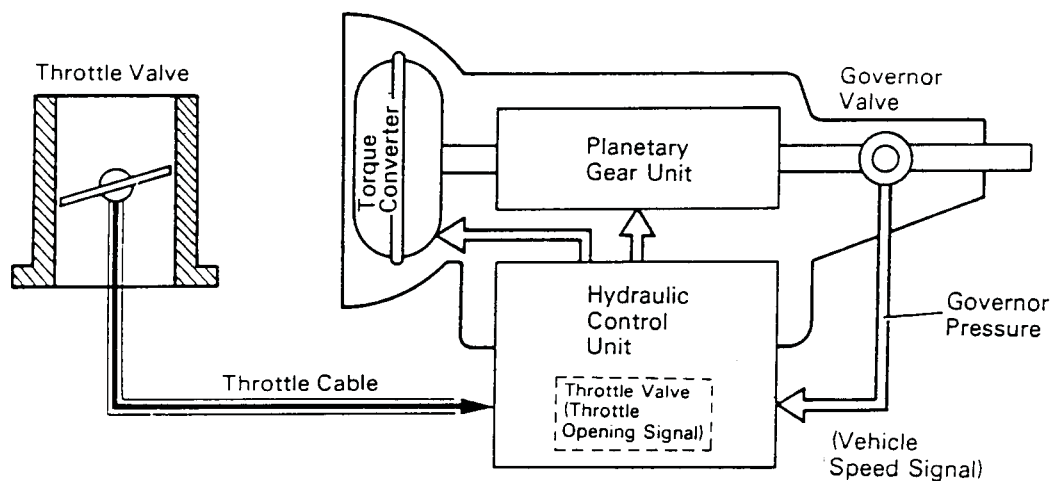

GOVERNOR VALVE

The governor valve generates hydraulic pressure in proportion to the speed of the vehicle; this pressure (called "governor pressure") acts as a vehicle speed "signal" to the hydraulic control unit.

THROTTLE VALVE

The throttle valve in the hydraulic control unit generates hydraulic pressure in proportion to the amount that the accelerator pedal is depressed; this pressure (called "throttle pressure") acts as a throttle opening "signal" to the hydraulic control unit.

HYDRAULIC CONTROL UNIT

Governor pressure and throttle pressure cause the shift valves in the hydraulic control unit to operate; the strengths of these pressures control the movements of these valves, and these valves control the fluid passage to the clutches and brakes in the planetary gear unit, which in turn control the shifting of the transmission.

AUTOMATIC TRANSMISSION SERVICE GROUP

• ECT

Aside from having an ECU which controls shifting based upon electrical speed and throttle opening signals, the ECT is basically the same as a fully hydraulic controlled automatic transmission. The ECT controls shifting in the following manner:

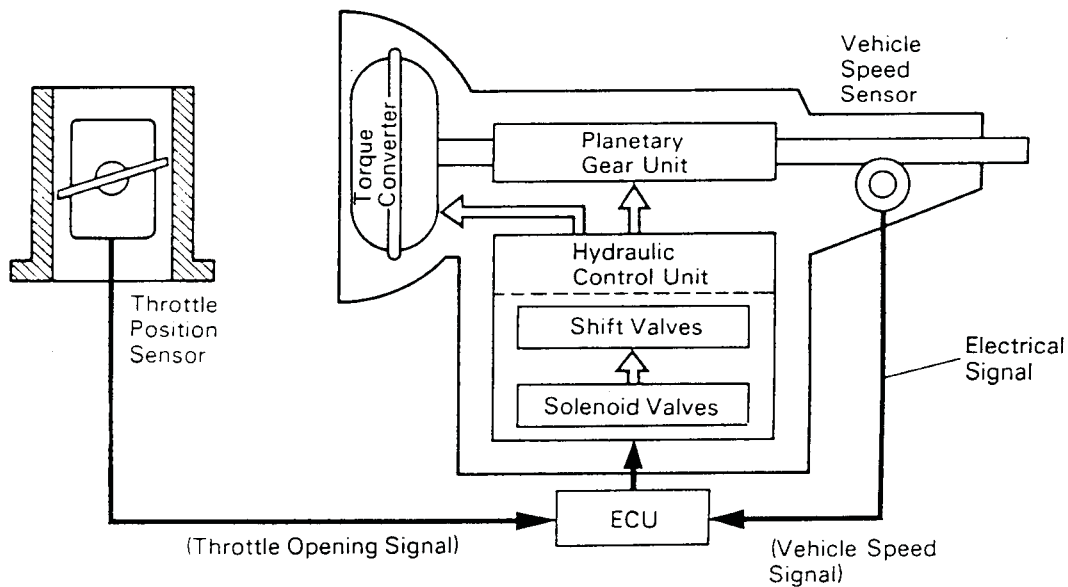

VEHICLE SPEED SENSOR

The vehicle speed is sensed by the vehicle speed sensor, which sends this data to the ECU in the form of electrical signals.

THROTTLE POSITION SENSOR

The throttle opening is sensed by the throttle position sensor, which sends this data to the ECU in the form of electrical signals.

ECU

The ECU determines the shift timing on the basis of the vehicle speed and throttle opening signals, and operates the solenoid valves in the hydraulic control unit, thus controlling the movement of the shift valves. These valves in turn control the fluid passage to the clutches and brakes in the planetary gear unit, which control the shifting of the transmission.



HYDRAULIC CONTROL SYSTEM

The hydraulic control system is composed of the oil pump, the valve body, the solenoid valves, and the clutches and brakes, as well as the fluid passages which connect all of these components. Based on the hydraulic pressure created by the oil pump, the hydraulic control system governs the hydraulic pressure acting on the torque converter, clutches and brakes in accordance with the vehicle driving conditions.

There are three solenoid valves on the valve body. These solenoid valves are turned on and off by signals from the ECU to operate the shift valves. These shift valves then switch the fluid passages so that fluid goes to the torque converter and planetary gear units.

(Except for the solenoid valves, the hydraulic control system of the ECT is basically the same as that of the fully hydraulic controlled automatic transmission.)

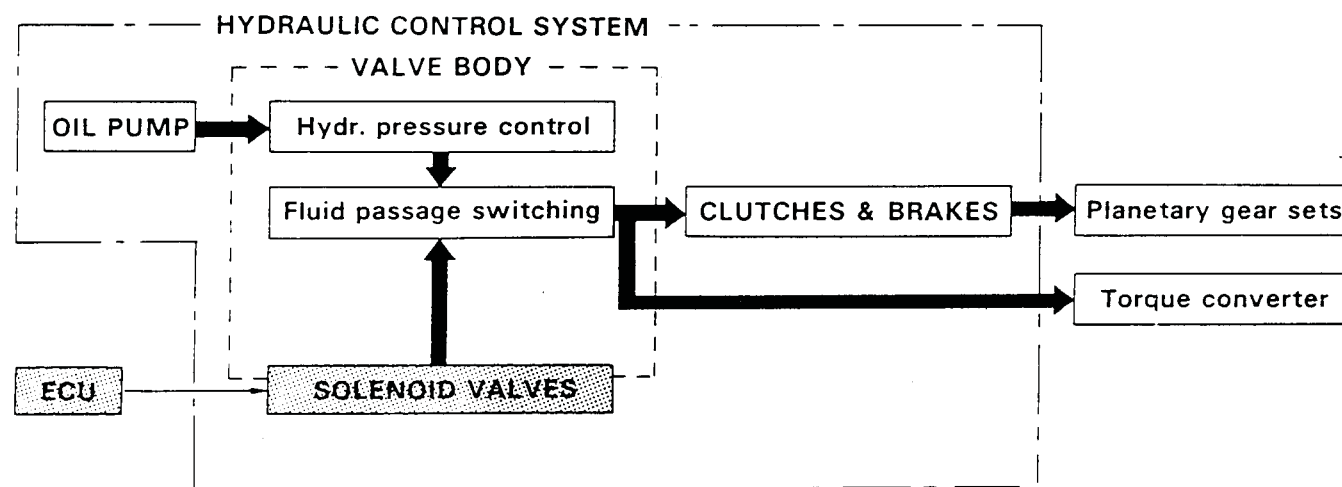

● LINE PRESSURE

Line pressure is the most basic and important pressure used in the automatic transmission, because it is used to operate all of the clutches and brakes in the transmission.

If the primary regulator valve does not operate correctly, line pressure will be either too high or too low. Line pressure that is too high will lead to shifting shock and consequent engine power loss due to the greater effort required of the oil pump; line pressure that is too low will cause slippage of clutches and brakes, which will, in extreme cases, prevent the vehicle from moving. Therefore, if either of these problems are noted, the line pressure should be measured to see if it is within standard.

● THROTTLE PRESSURE

Throttle pressure is always kept in accordance with the opening angle of the engine throttle valve. This throttle pressure acts on the primary regulator valve and, accordingly, line pressure is regulated in response to the throttle valve opening.

In the fully hydraulic controlled automatic transmission, throttle pressure is used for regulating line pressure and as signal pressure for up-shift and down-shift of the transmission. In the ECT, however, throttle pressure is used only for regulating line pressure. Consequently, improper adjustment of the transmission throttle cable may result in a line pressure that is too high or too low. This, in turn, will lead to shifting shock or clutch and brake slippage.



ELECTRONIC CONTROL SYSTEM

The electronic control system, which controls the shift points and the operation of the lock-up clutch, is composed of the following three parts:

1. **Sensors**

These sensors sense the vehicle speed, throttle opening and other conditions and send this data to the ECU in the form of electrical signals.

2. **ECU**

The ECU determines the shift and lock-up timing based upon the signals from sensors, and controls the solenoid valves of the hydraulic control unit accordingly.

3. **Actuators**

These are three solenoid valves that control hydraulic pressure acting on the hydraulic valves to control shifting and lock-up timing.

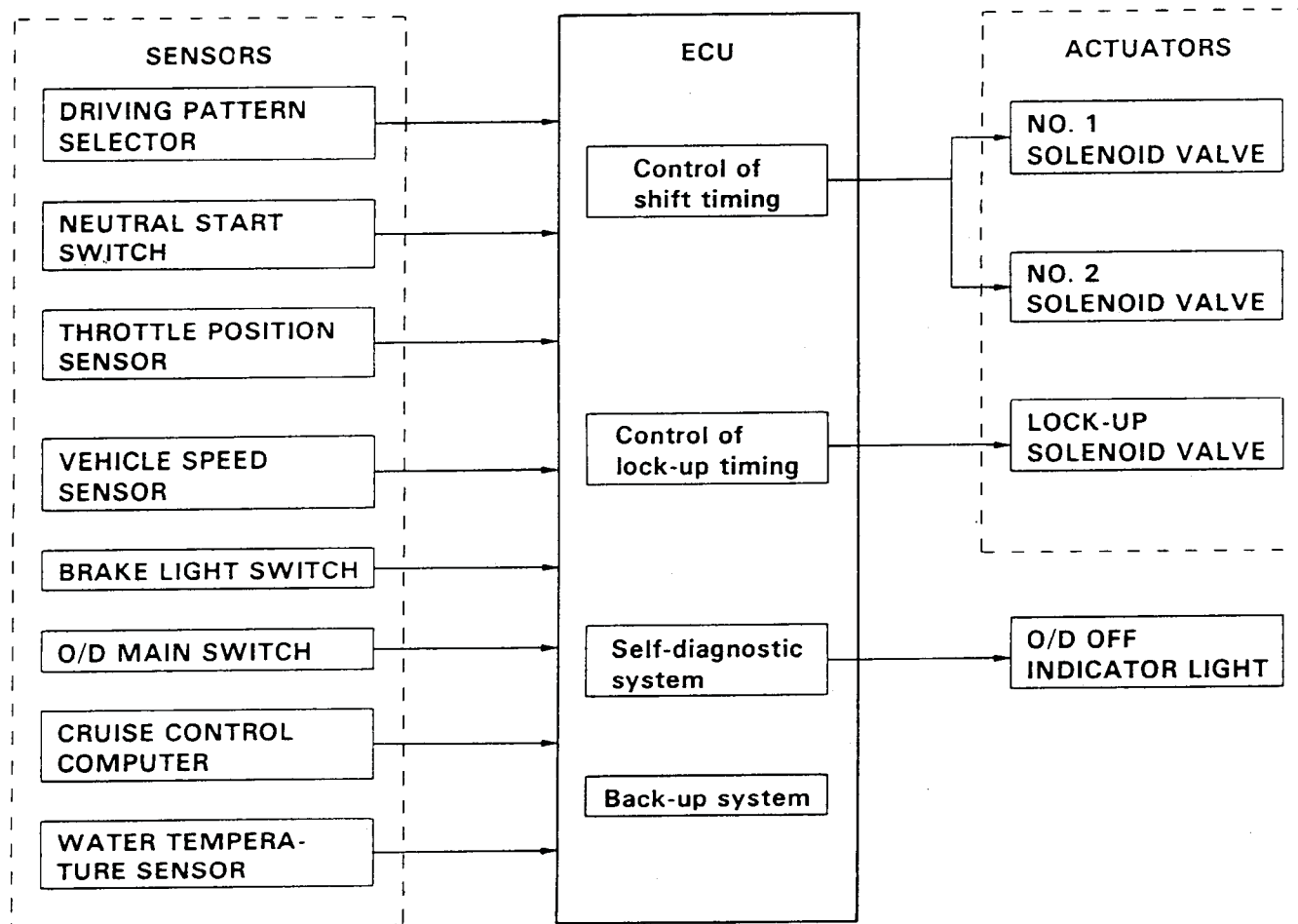



Technical Service Information

FUNCTION OF ECU

● Control of Shift Timing

The ECU has programmed into its memory the optimum shift pattern for each shift lever position (D, 2, L range) and driving mode (Normal or Power).

Based on the appropriate shift pattern, the ECU turns No. 1 and No. 2 solenoid valves on or off in accordance with the vehicle speed signal from the vehicle speed sensor and the throttle opening signal from the throttle position sensor. In this manner, the ECU operates each shift valve, opening or closing the fluid passages to the clutches and brakes to permit up-shift or down-shift of the transmission.

NOTE: The electronic control system provides shift timing and lock-up control only while the vehicle is traveling forward. In REVERSE, PARK, and NEUTRAL, the transmission is mechanically, not electronically controlled.

● Control of Overdrive

Driving in overdrive is possible if the O/D main switch is on and the shift lever is in the D range. However, when the vehicle is being driven using the cruise control system (CCS), if the actual vehicle speed drops to about 10 km/h (6 mph) below the set speed while the vehicle is running in overdrive, the CCS computer sends a signal to the TCCS ECU to release the overdrive and prevent the transmission from shifting back into overdrive until the actual vehicle speed reaches the speed set in the CCS memory.

On this model, if the coolant temperature falls below 60°C (140°F), preventing the transmission from up-shifting into overdrive.

● Control of Lock-up System

The TCCS ECU has programmed in its memory a lock-up clutch operation pattern for each driving mode (Normal or Power). Based on this lock-up pattern, the ECU turns lock-up solenoid valve on or off in accordance with the vehicle speed signals received from the vehicle speed sensor and the throttle opening signals from the throttle position sensor.

Depending on whether lock-up solenoid valve is on or off, the lock-up relay valve performs changeover of the fluid passages for the converter pressure acting on the torque converter to engage or disengage the lock-up clutch.

(Mandatory Cancellation of Lock-up System)

If any of the following conditions exist, the ECU turns off lock-up solenoid valve to disengage the lock-up clutch.

- 1) The brake light switch comes on (during braking).
- 2) The IDL points of the throttle position sensor close (throttle valve fully closed).
- 3) The vehicle speed drops 10 km/h (6 mph) or more below the set speed while the cruise control system is operating.
- 4) The coolant temperature falls below 60°C (140°F).

The purpose of 1) and 2) above is to prevent the engine from stalling if the front wheels lock up. The purpose of 3) is to cause the torque converter to operate to obtain torque multiplication. The purpose of 4) is both to improve general driveability, and to speed up transmission warm-up.

Also, while the lock-up system is in operation, the ECU will temporarily turn it off during up-shift or down-shift in order to decrease shifting shock.



General Troubleshooting

Problem	Possible cause	Remedy
Fluid discolored or smells burnt	Fluid contaminated Torque converter faulty Transmission faulty	Replace fluid Replace torque converter Disassemble and inspect transmission
Vehicle does not move in any forward range or reverse	Shift cable out of adjustment Valve body or primary regulator faulty Parking lock pawl faulty Torque converter faulty Converter drive plate broken Oil pump intake screen blocked Transmission faulty	Adjust shift cable Inspect valve body Inspect parking lock pawl Replace torque converter Replace drive plate Clean screen Disassemble and inspect transmission
Shift lever position incorrect	Shift cable out of adjustment Manual valve and lever faulty Transmission faulty	Adjust shift cable Inspect valve body Disassemble and inspect transmission
Harsh engagement into any drive range	Throttle cable out of adjustment Valve body or primary regulator faulty Accumulator pistons faulty Transmission faulty	Adjust throttle cable Inspect valve body Inspect accumulator pistons Disassemble and inspect transmission
Delayed 1-2, 2-3 or 3-O/D up-shift, or down-shifts from O/D-3 or 3-2 and shifts back to O/D or 3	Electronic control faulty Valve body faulty Solenoid valve faulty	Inspect electronic control Inspect valve body Inspect solenoid valve
Slips on 1-2, 2-3 or 3-O/D up-shift, or slips or shudders on acceleration	Shift cable out of adjustment Throttle cable out of adjustment Valve body faulty Solenoid valve faulty Transmission faulty	Adjust shift cable Adjust throttle cable Inspect valve body Inspect solenoid valve Disassemble and inspect transmission
Drag, binding or tie-up on 1-2, 2-3 or 3-O/D up-shift	Shift cable out of adjustment Valve body faulty Transmission faulty	Adjust shift cable Inspect valve body Disassemble and inspect transmission



Technical Service Information

General Troubleshooting (Cont'd)

Problem	Possible cause	Remedy
No lock-up in 2nd, 3rd or O'D	Electronic control faulty Valve body faulty Solenoid valve faulty Transmission faulty	Inspect electronic control Inspect valve body Inspect solenoid valve Disassemble and inspect transmission
Harsh down-shift	Throttle cable out of adjustment Throttle cable and cam faulty Accumulator pistons faulty Valve body faulty Transmission faulty	Adjust throttle cable Inspect throttle cable and cam Inspect accumulator pistons Inspect valve body Disassemble and inspect transmission
No down-shift when coasting	Valve body faulty Solenoid valve faulty Electronic control faulty	Inspect valve body Inspect solenoid valve Inspect electronic control
Down-shift occurs too quickly or too late while coasting	Throttle cable faulty Valve body faulty Transmission faulty Solenoid valve faulty Electronic control faulty	Inspect throttle cable Inspect valve body Disassemble and inspect transmission Inspect solenoid valve Inspect electronic control
No O-D-3, 3-2 or 2-1 kick-down	Solenoid valve faulty Electronic control faulty Valve body faulty	Inspect solenoid valve Inspect electronic control Inspect valve body
No engine braking in 2 or L range	Solenoid valve faulty Electronic control faulty Valve body faulty Transmission faulty	Inspect solenoid valve Inspect electronic control Inspect valve body Disassemble and inspect transmission
Vehicle does not hold in P	Shift cable out of adjustment Parking lock pawl cam and spring faulty	Adjust shift cable Inspect cam and spring



Technical Service Information

Operating Mechanism for Each Gear

1. CLUTCH BRAKE AND ONE-WAY CLUTCH

○ Operating

Shift lever position	Gear position	C ₀	C ₁	C ₂	B ₀	B ₁	B ₂	B ₃	F ₀	F ₁	F ₂
P	Parking	○									
R	Reverse	○		○				○			
N	Neutral	○									
D	1st	○	○						○		○
	2nd	○	○				○		○	○	
	3rd	○	○	○			○		○		
	O/D		○	○	○		○				
2	1st	○	○						○		○
	2nd	○	○			○	○		○	○	
	*3rd	○	○	○			○		○		
L	1st	○	○					○	○		○
	*2nd	○	○			○	○		○	○	

*Down-shift only — no up-shift

2. SOLENOID SYSTEM

Possible gear positions in accordance with solenoid operating conditions.

Range	NORMAL			NO. 1 SOLENOID MALFUNCTIONING			NO. 2 SOLENOID MALFUNCTIONING			BOTH SOLENOIDS MALFUNCTIONING		
	Solenoid Valve		Gear Position	Solenoid Valve		Gear Position	Solenoid Valve		Gear Position	Solenoid Valve		Gear Position
	No. 1	No. 2		No. 1	No. 2		No. 1	No. 2		No. 1	No. 2	
D range	ON	OFF	1st	X	ON (OFF)	3rd (O/D)	ON	X	1st	X	X	O/D
	ON	ON	2nd	X	ON	3rd	OFF (ON)	X	O/D (1st)	X	X	O/D
	OFF	ON	3rd	X	ON	3rd	OFF	X	O/D	X	X	O/D
	OFF	OFF	O/D	X	OFF	O/D	OFF	X	O/D	X	X	O/D
2 range	ON	OFF	1st	X	ON (OFF)	3rd (O/D)	ON	X	1st	X	X	O/D
	ON	ON	2nd	X	ON	3rd	OFF (ON)	X	O/D (1st)	X	X	O/D
	OFF	ON	3rd	X	ON	3rd	OFF	X	O/D	X	X	O/D
L range	ON	OFF	1st	X	OFF	1st	ON	X	1st	X	X	1st
	ON	ON	2nd	X	ON	2nd	ON	X	1st	X	X	1st

(): No fail-safe function X: Malfunctions

AUTOMATIC TRANSMISSION SERVICE GROUP



Technical Service Information

Diagnosis System

DESCRIPTION

1. A self-diagnosis function is built into the electrical control system. Warning is indicated by the overdrive OFF indicator.

NOTE: Warning and diagnostic codes can be read only when the overdrive switch is ON. If OFF, the overdrive OFF indicator is lit continuously and will not blink.

- (a) If a malfunction occurs within the speed sensors (No. 1 or 2) or solenoids (No. 1 or 2), the overdrive OFF light will blink to warn the driver. However, there will be no warning of a malfunction with lock-up solenoid.
- (b) The diagnostic code can be read by the number of blinks of the overdrive OFF indicator when terminals TE_1 and E_1 are short-circuited.
- (c) The throttle position sensor or brake signal are not indicated, but inspection can be made by checking the voltage at terminal ECT of the service connector (diagnosis).
- (d) The signals to each gear can be checked by measuring the voltage at terminal ECT of the service connector while driving.

2. The diagnostic (malfunction) code is retained in memory by the CPU and due to back-up voltage, is not canceled out when the engine is turned off. Consequently, after repair, it is necessary to turn the ignition switch off and remove the fuse EFI (15A) or disconnect the TCCS ECU connector to cancel out the diagnostic (malfunction) code.

NOTE:

- Low battery voltage will cause faulty operation of the diagnosis system. Therefore, always check the battery first.
- Use a voltmeter and ohmmeter that have an impedance of at least $10\text{ k}\Omega/\text{V}$.

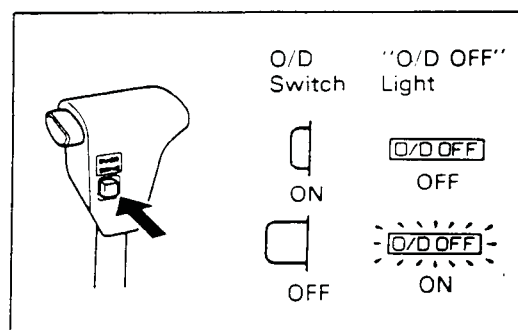
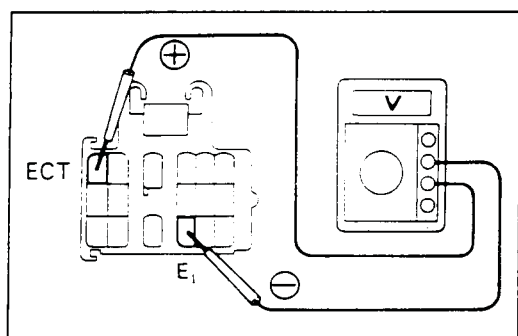
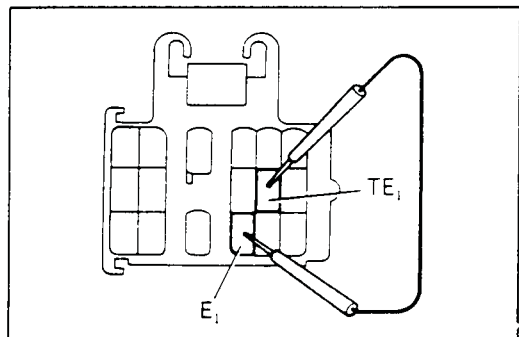
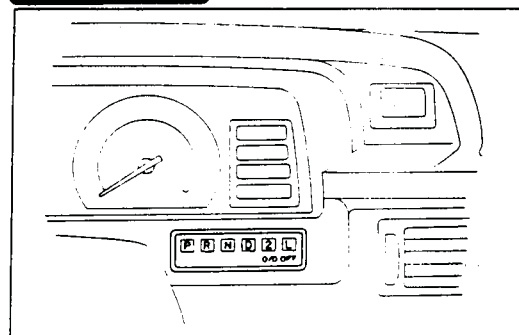

CHECK O/D OFF INDICATOR LIGHT

1. Turn the ignition switch ON.
2. The O/D OFF light will come on when the O/D switch is placed at OFF.
3. When the O/D switch is set to ON, the O/D OFF light should go out.

If the O/D OFF light flashes when the O/D switch is set to ON, the electronic control system is faulty.

AUTOMATIC TRANSMISSION SERVICE GROUP



Technical Service Information

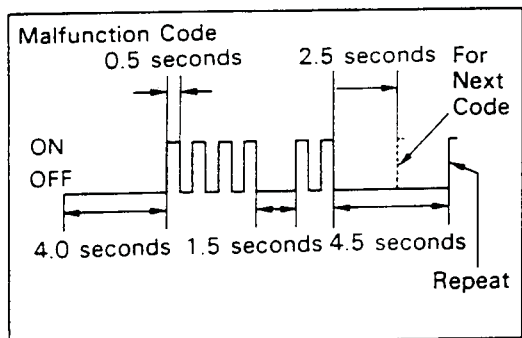
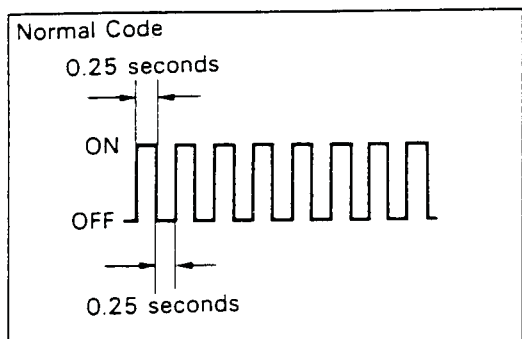
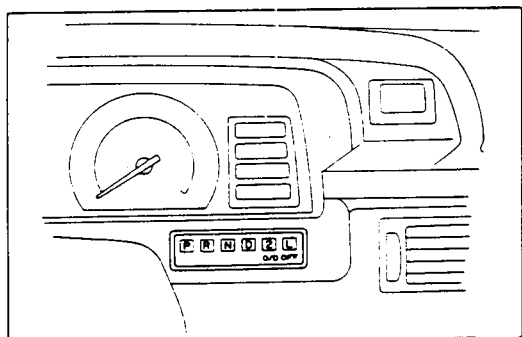
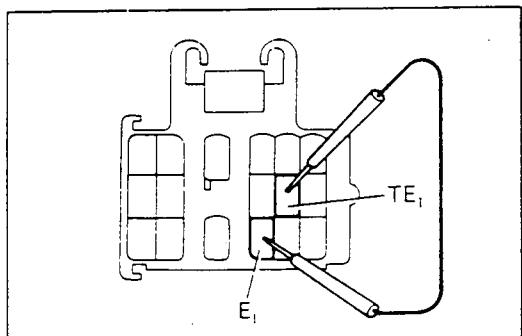
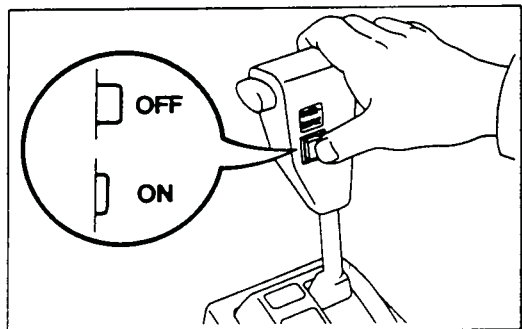

READ DIAGNOSTIC CODE

1. TURN IGNITION SWITCH AND O/D SWITCH TO ON

Do not start the engine.

NOTE: Warning and diagnostic codes can be read only when the overdrive switch is ON. If OFF, the overdrive OFF light will light continuously and will not blink.

2. SHORT TE₁ TERMINAL CIRCUIT OF SERVICE CONNECTOR

Using a service wire, short terminals TE₁ and E₁ of the service connector.

3. READ DIAGNOSTIC CODE

Read the diagnostic code as indicated by the number of times the O/D OFF light flashes.

(Diagnostic Code Indication)

- If the system is operating normally, the light will blink once every 0.25 seconds.

- In the event of a malfunction, the light will blink once every 0.5 seconds. The number of blinks will equal the first number and, after 1.5 seconds pause, the second number of the two digit diagnostic code. If there are two or more codes, there will be a 2.5 seconds pause between each.

NOTE: In the event of several trouble codes occurring simultaneously, indication will begin from the smaller value and continue to the larger.

4. REMOVE SERVICE WIRE

AUTOMATIC TRANSMISSION SERVICE GROUP



Technical Service Information

Diagnostic code 62 (No. 1 solenoid valve circuitry)

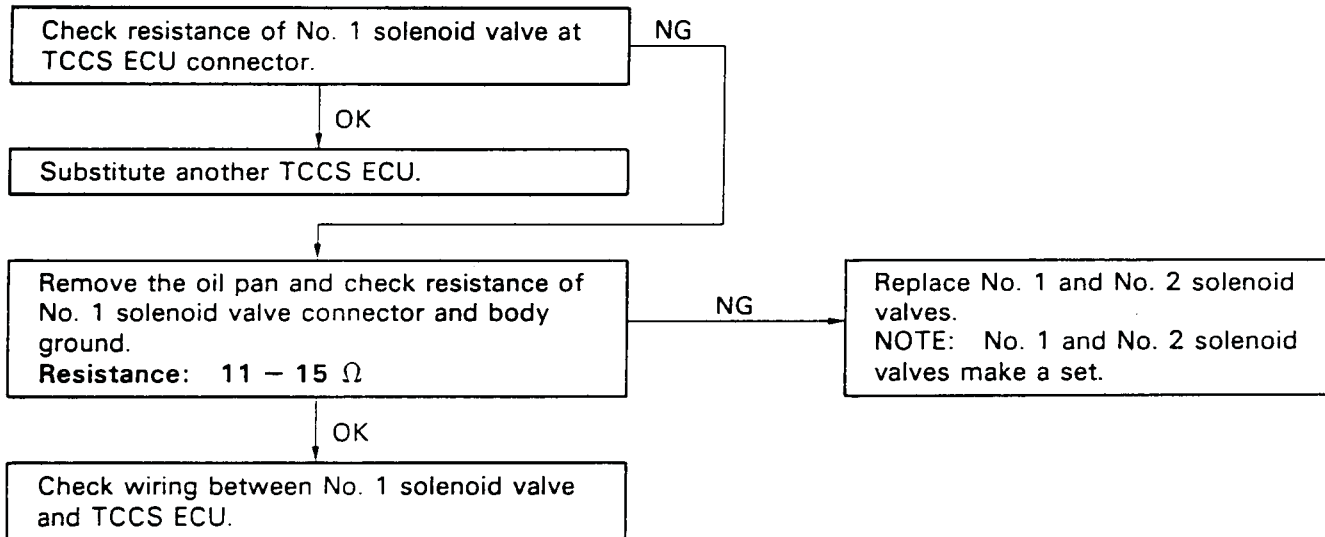

Diagnostic code 63 (No. 2 solenoid valve circuitry)

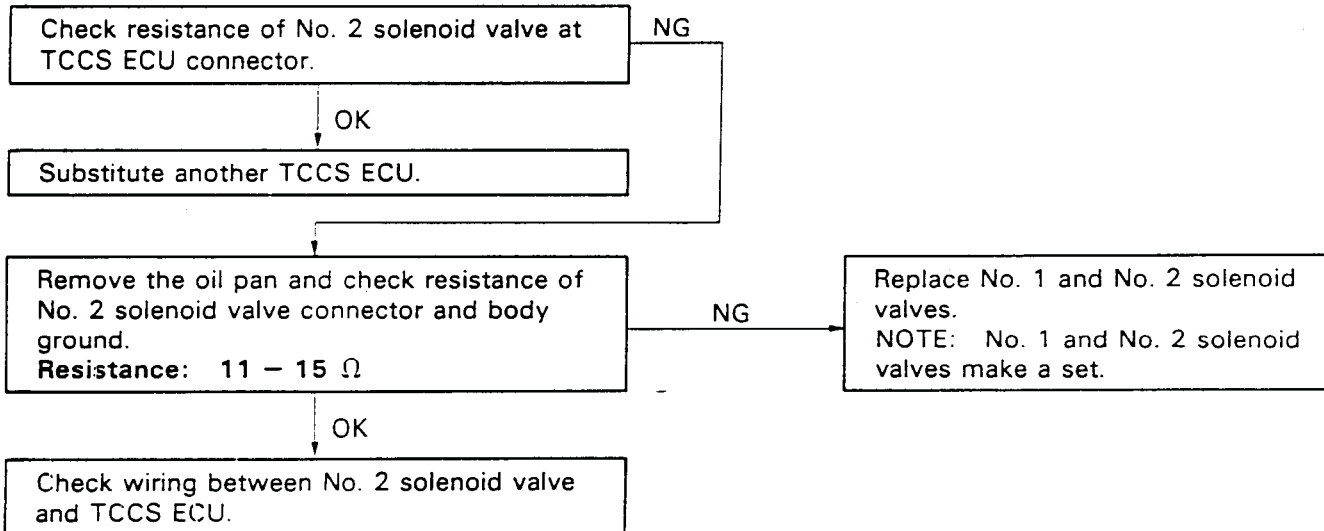

Diagnostic code 64 (Lock-up solenoid valve circuitry)

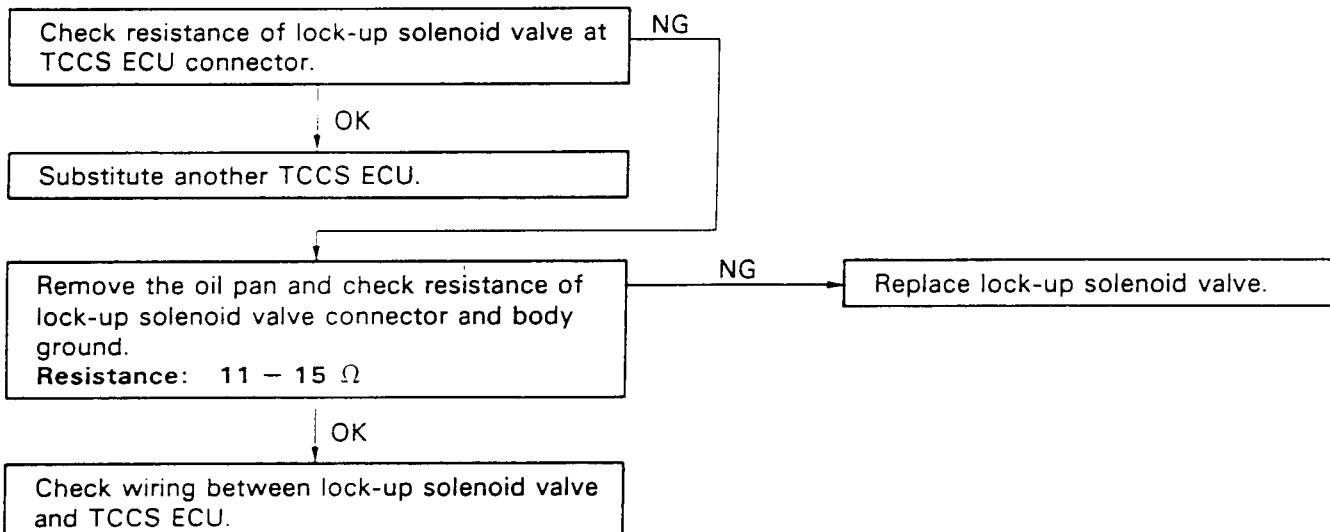



Technical Service Information

TROUBLESHOOTING FLOW-CHART

NOTE:

- If diagnostic code Nos. 42, 61, 62 or 63 are output, the overdrive OFF indicator light will begin to blink immediately to warn the driver. However, an impact or shock may cause the blinking to stop; but the code will still be retained in the TCCS ECU memory until canceled out.
- There is no warning for diagnostic code No. 64.
- In the event of a simultaneous malfunction of both No. 1 and No. 2 speed sensors, no diagnostic code will appear and the fail-safe system will not function. However, when driving in the D range, the transmission will not up-shift from first gear, regardless of the vehicle speed.

Diagnostic code 42 (No. 1 speed sensor circuitry)

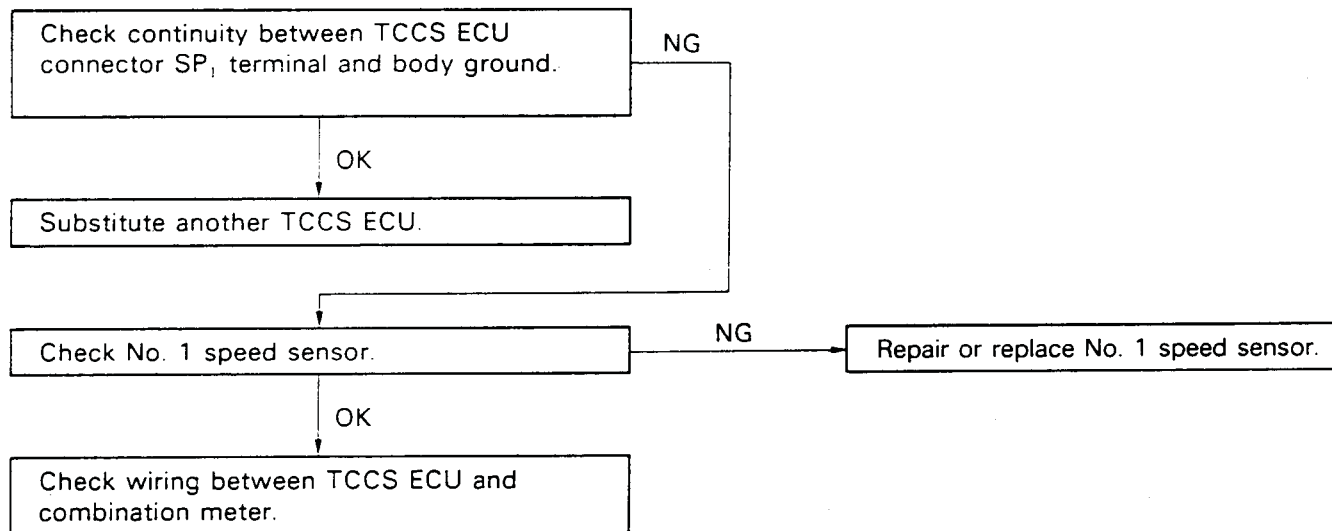

Diagnostic code 61 (No. 2 speed sensor circuitry)

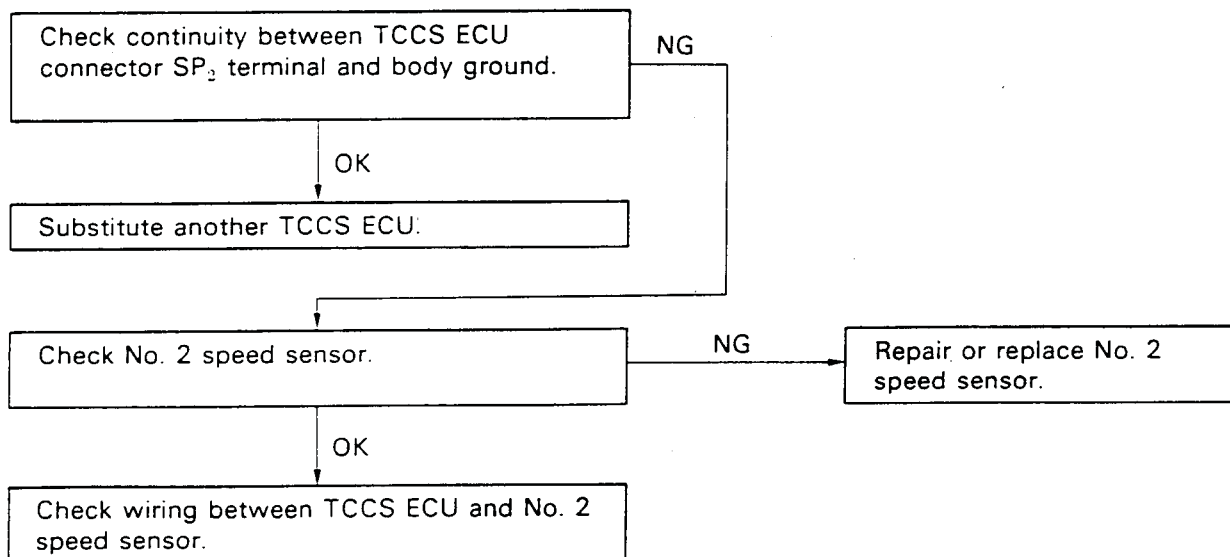

AUTOMATIC TRANSMISSION SERVICE GROUP



Technical Service Information
Electronic Control System
ELECTRONIC CONTROL CIRCUIT

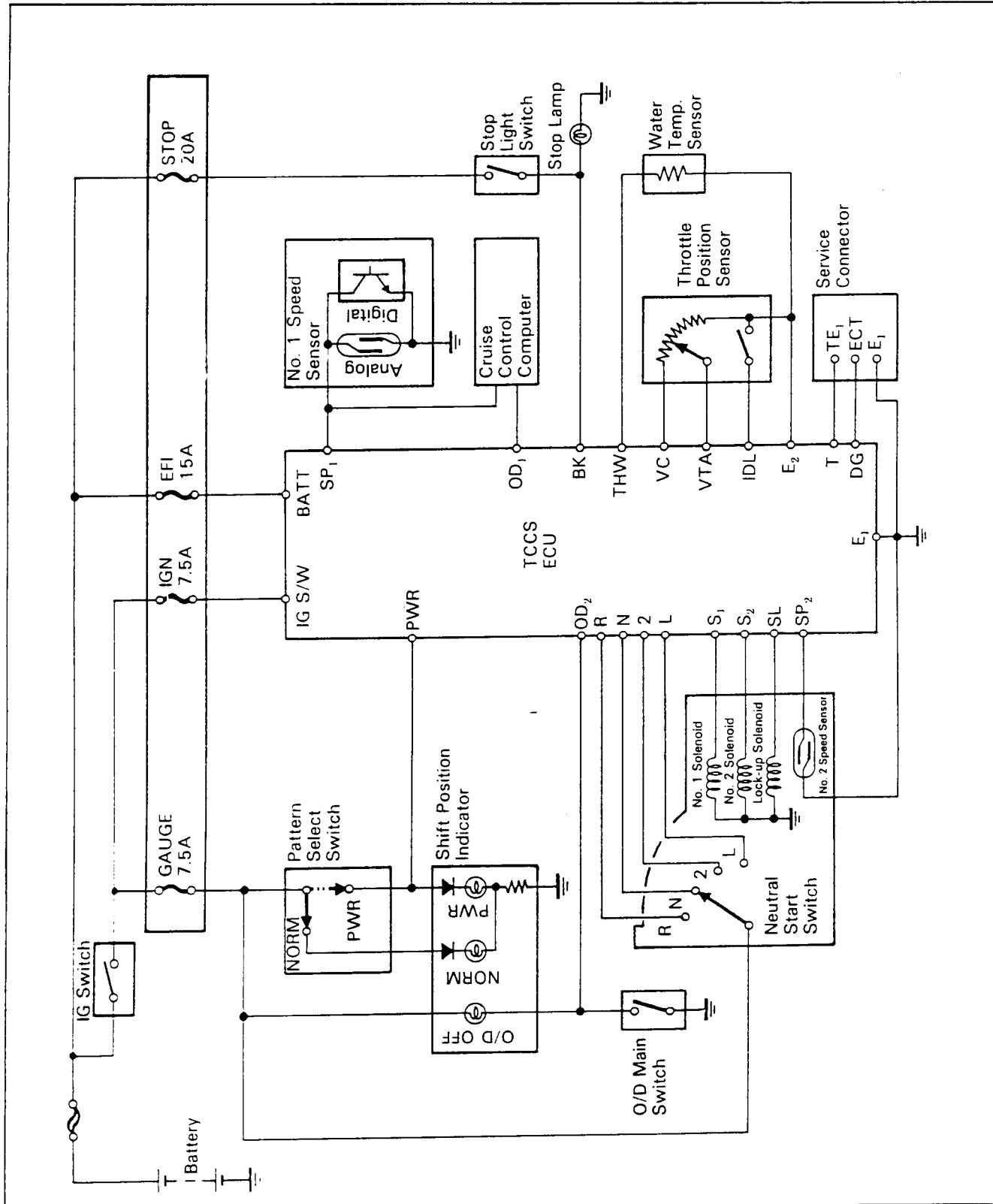

AUTOMATIC TRANSMISSION SERVICE GROUP



Technical Service Information

ELECTRONIC CONTROL COMPONENTS

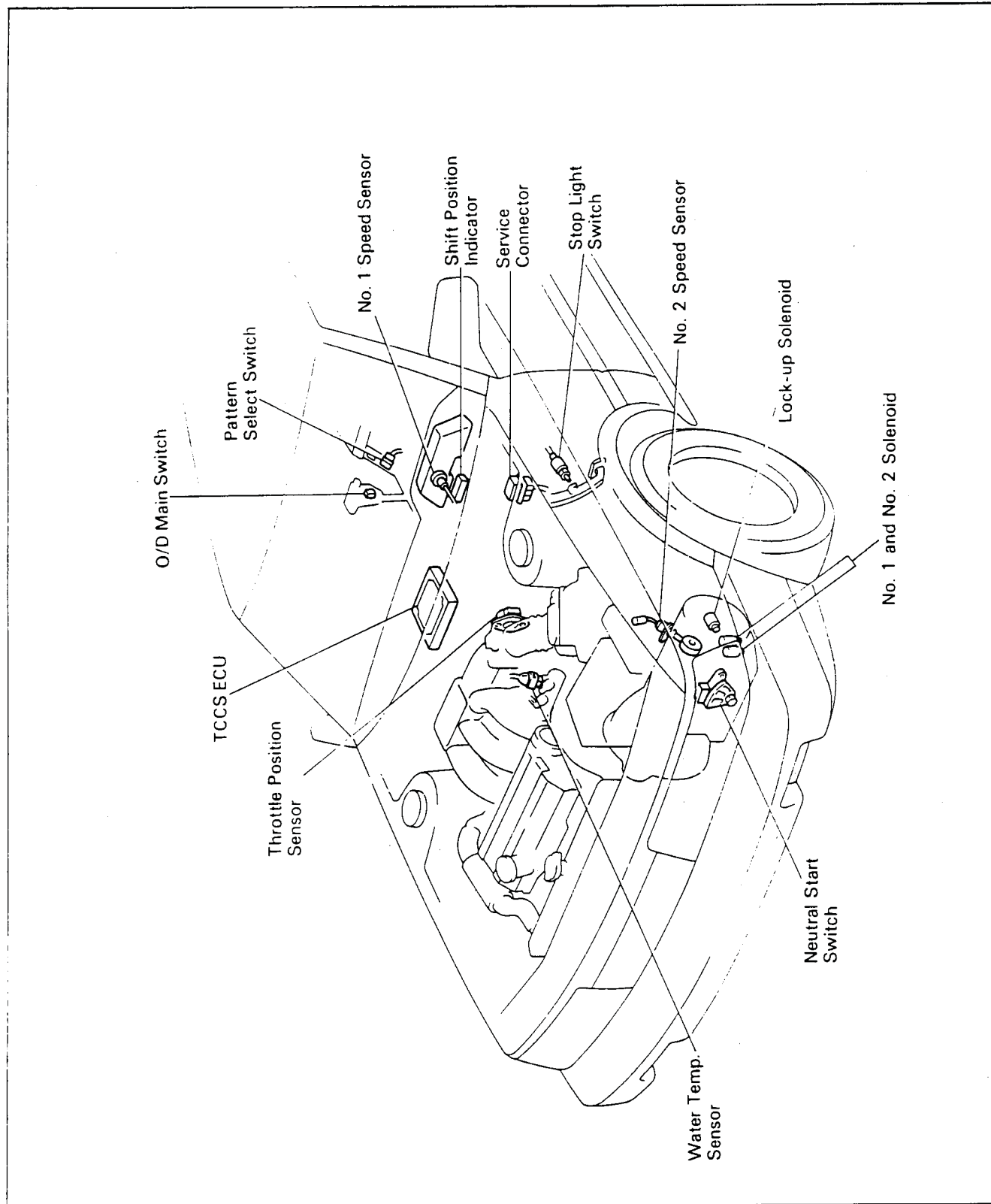

AUTOMATIC TRANSMISSION SERVICE GROUP



Technical Service Information

REMOVAL OF COMPONENT PARTS COMPONENTS

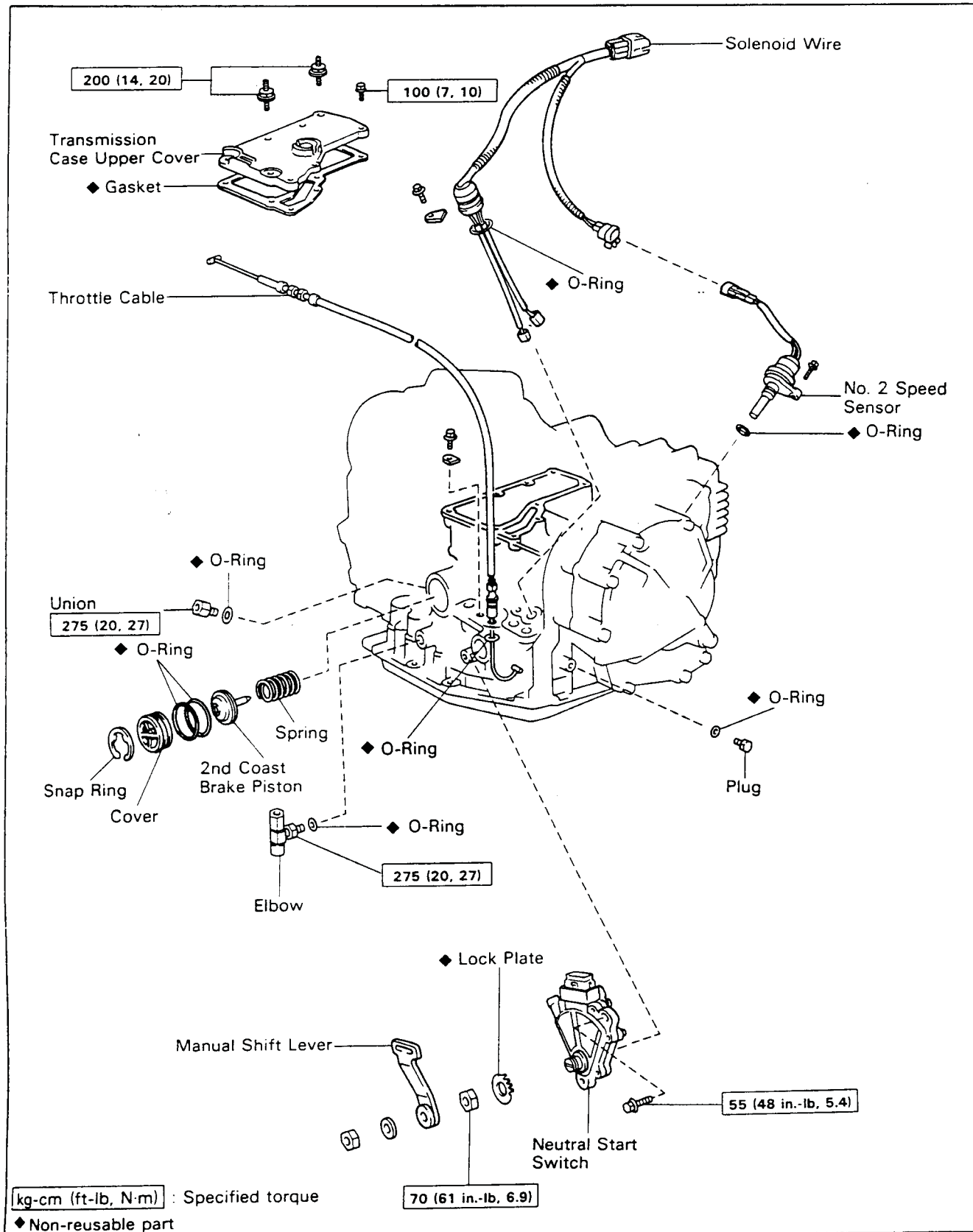

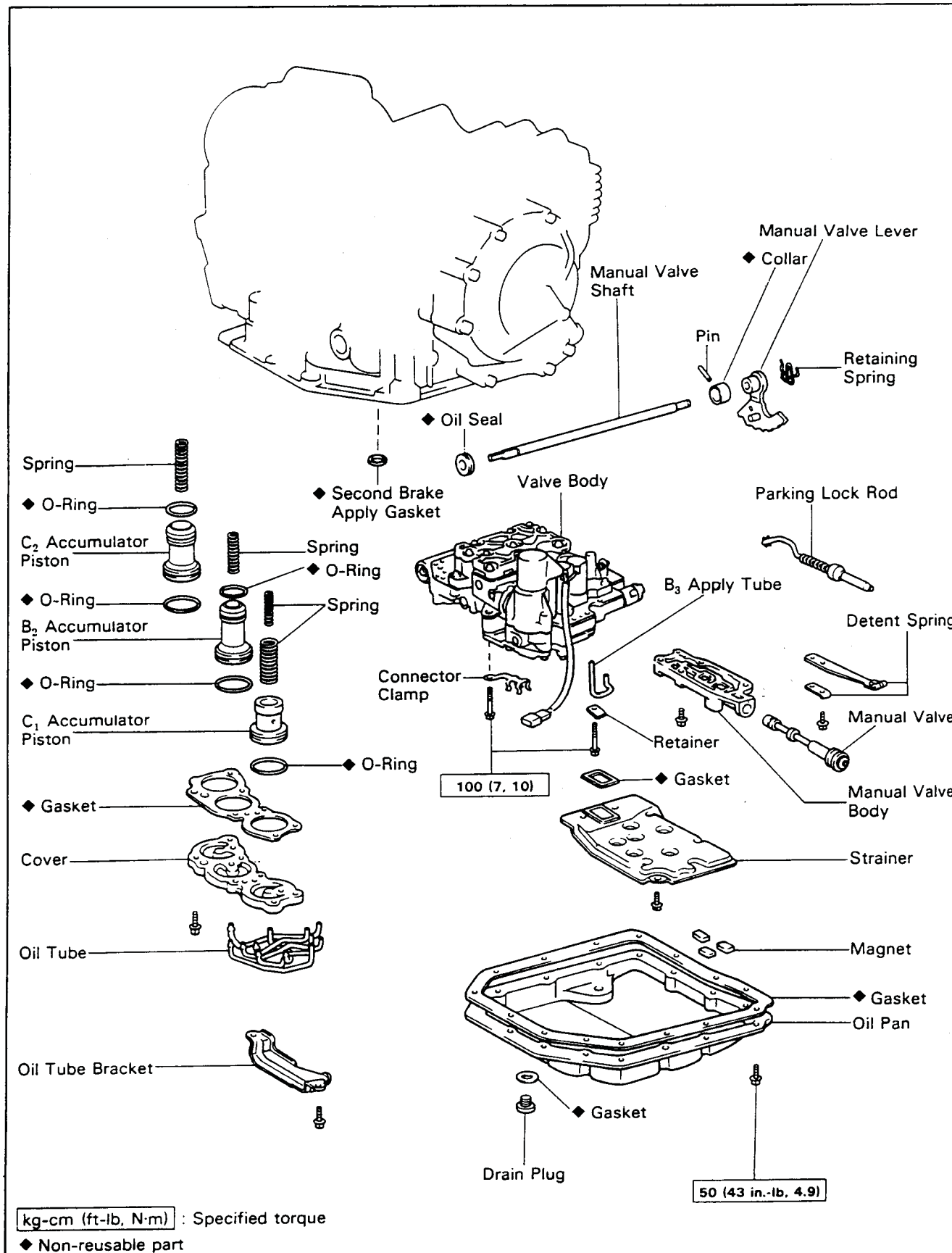

Technical Service Information

COMPONENTS (Cont'd)

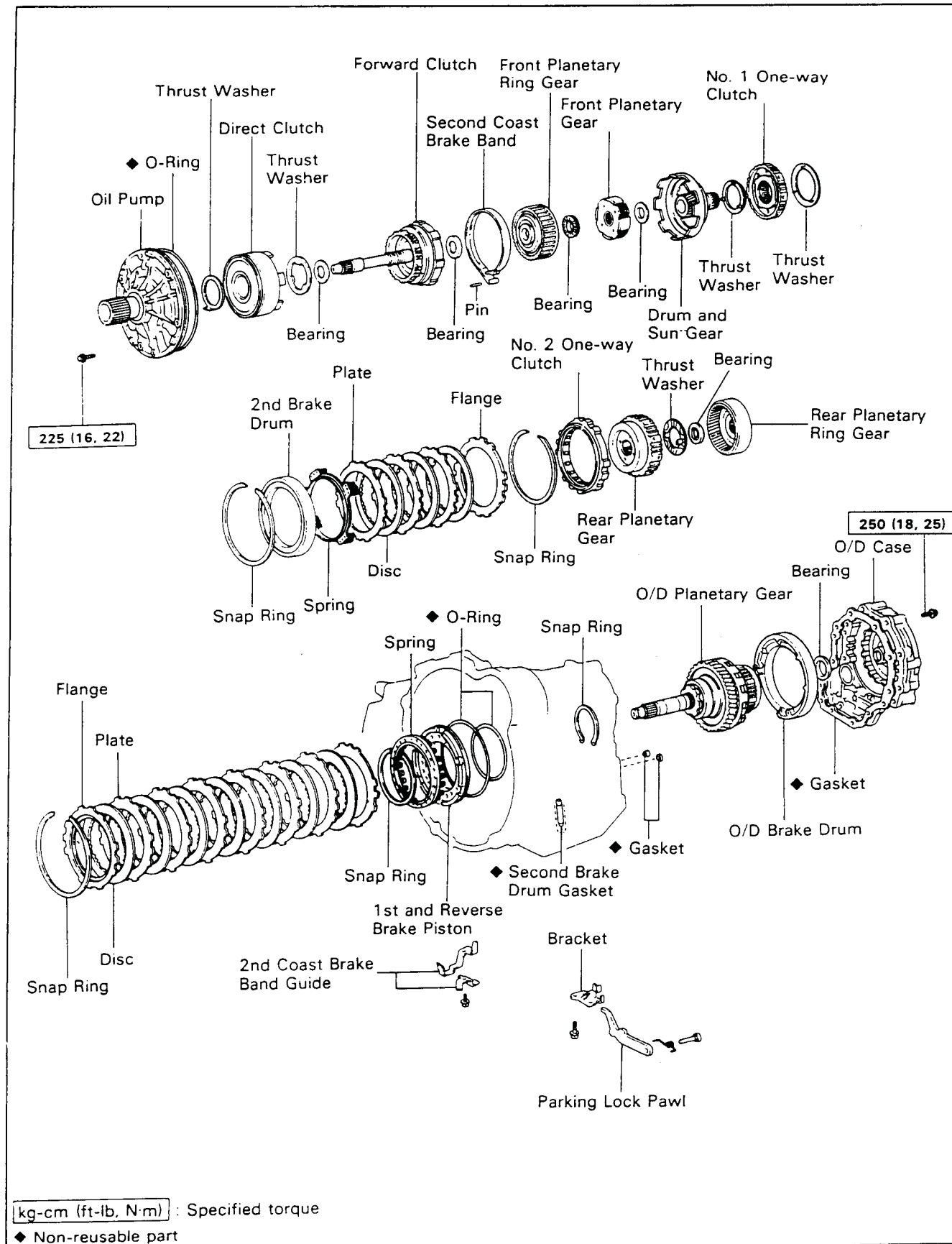

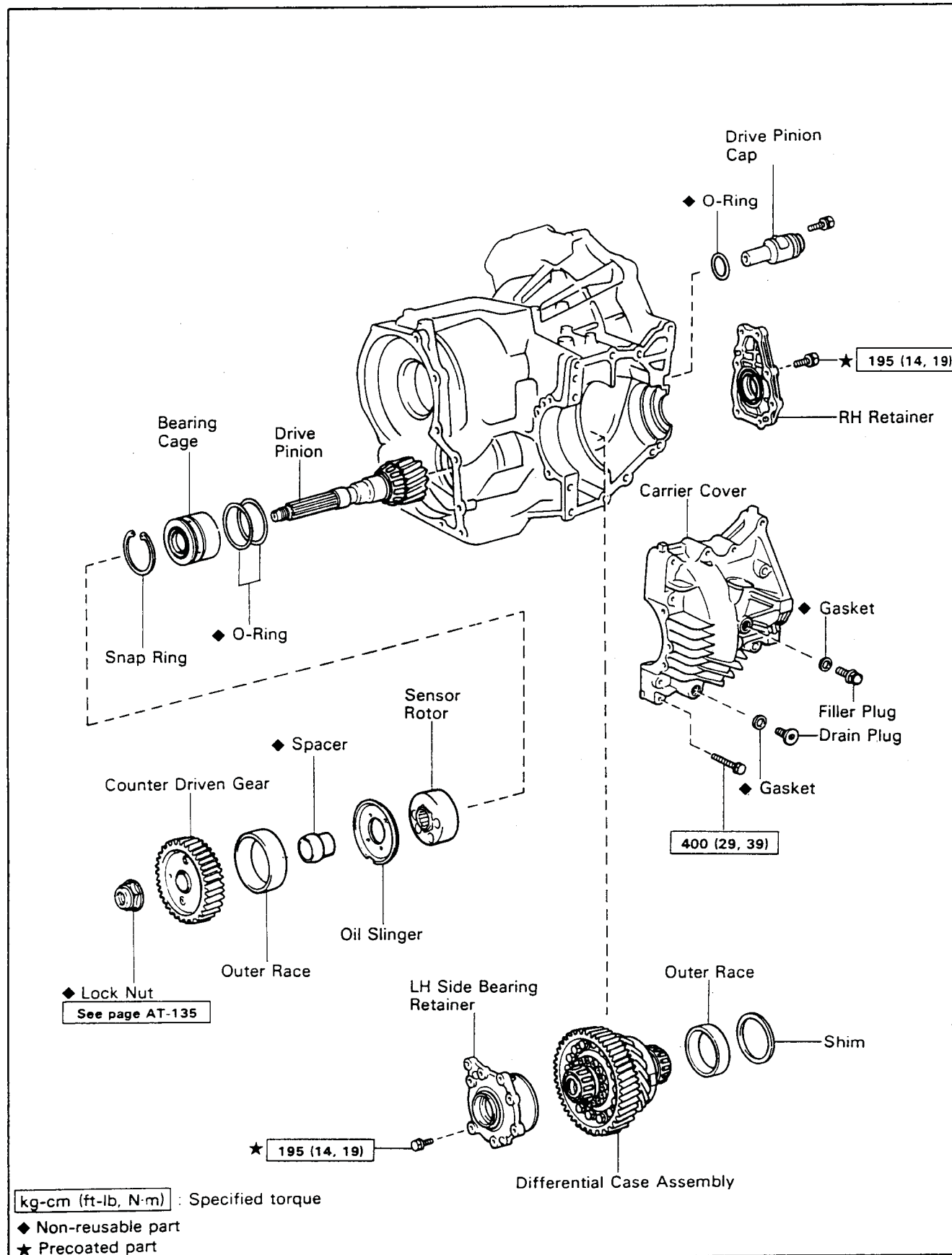



Technical Service Information

SEPARATE BASIC SUBASSEMBLY

REMOVE UNION AND ELBOW

Using the open end wrench, remove the union and elbow.

Remove the O-rings from the union and elbow.

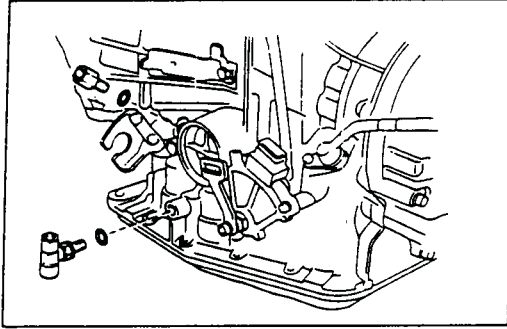

REMOVE NEUTRAL START SWITCH

Remove the manual shift lever.

Pry off the lock washer and remove the manual valve shaft nut.

Remove the two bolts and pull out the neutral start switch.

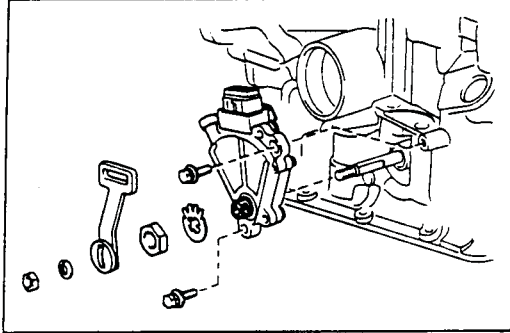

REMOVE THROTTLE CABLE RETAINING PLATE

REMOVE SOLENOID WIRE RETAINING BOLT

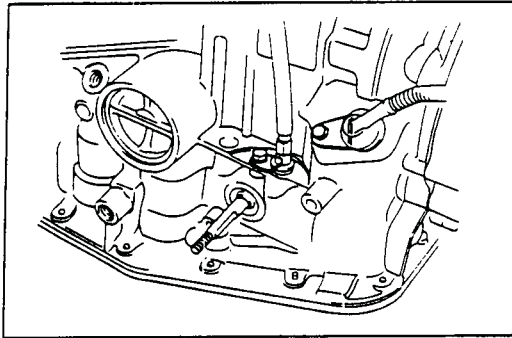

REMOVE SPEED SENSOR

Disconnect the connector.

Remove the bolt and pull out the speed sensor.

Remove the O-ring from speed sensor.

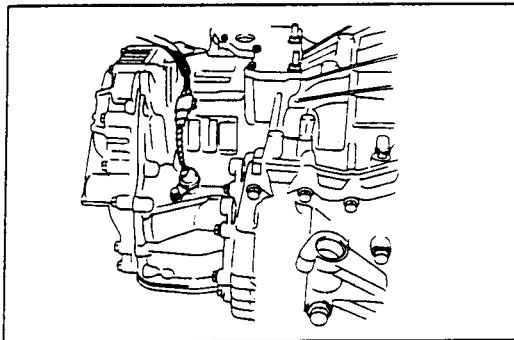

REMOVE TUBE BRACKET AND OIL STRAINER

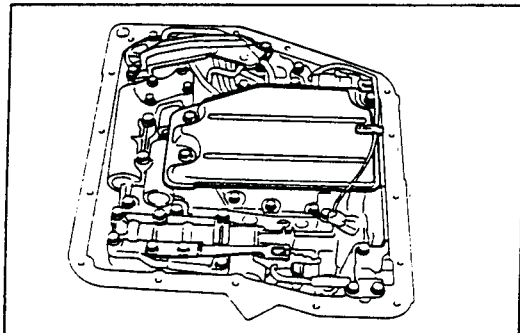



Technical Service Information

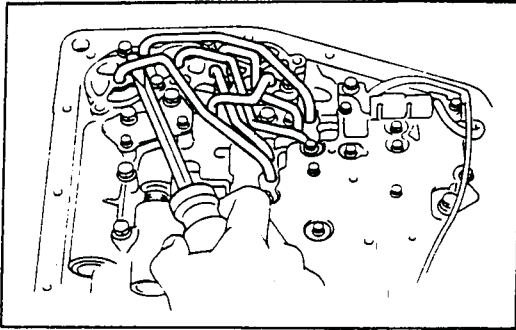

REMOVE OIL TUBES

Pry up both tube ends with a large screwdriver and remove the six tubes.

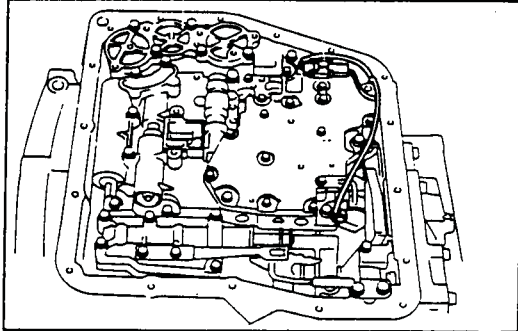

DISCONNECT SOLENOID CONNECTORS

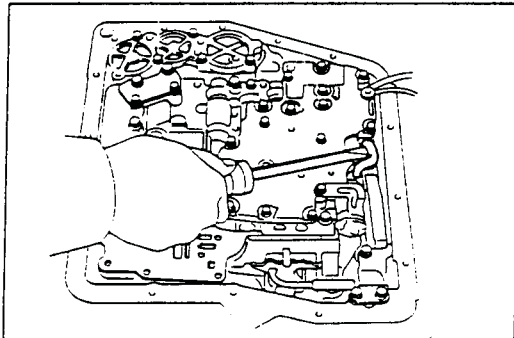

REMOVE B₃ APPLY TUBE

Pry up the tube with a screwdriver and remove the tube.

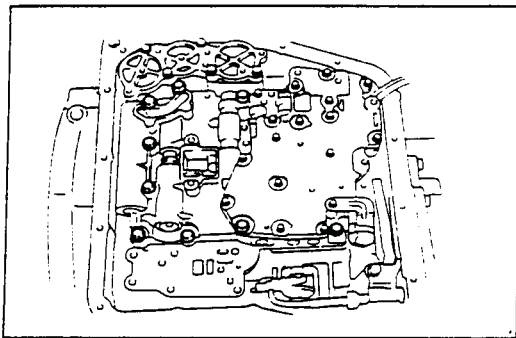

REMOVE VALVE BODY

Remove the nine bolts.

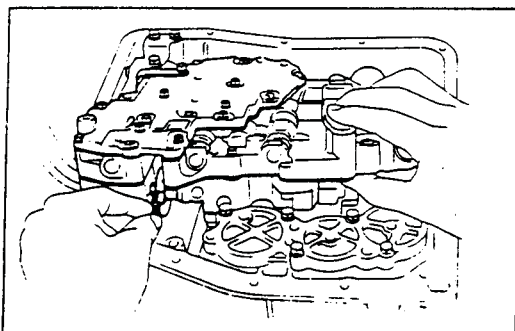

Disconnect the throttle cable from the cam and remove the valve body.



Technical Service Information

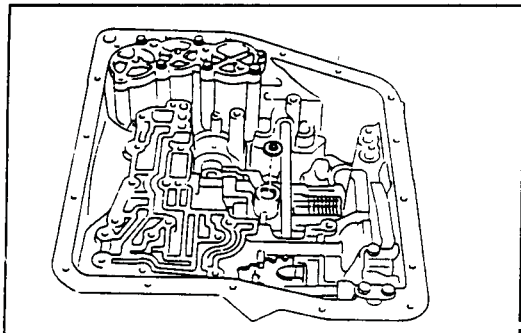

REMOVE SECOND BRAKE APPLY GASKET

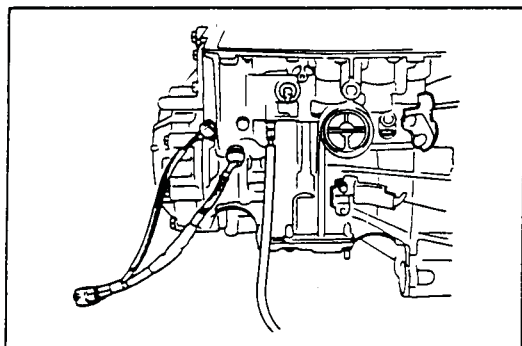

REMOVE THROTTLE CABLE AND SOLENOID WIRE

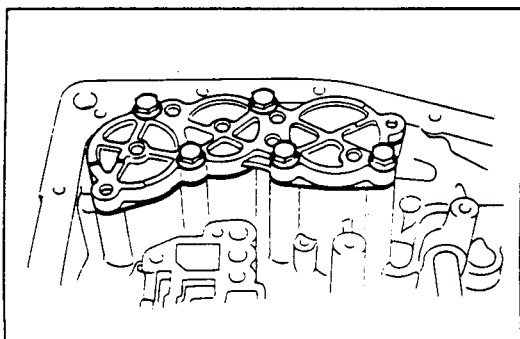

REMOVE ACCUMULATOR PISTONS AND SPRINGS

Loosen the five bolts one turn at a time until the spring tension is released.

Remove the cover and gasket.

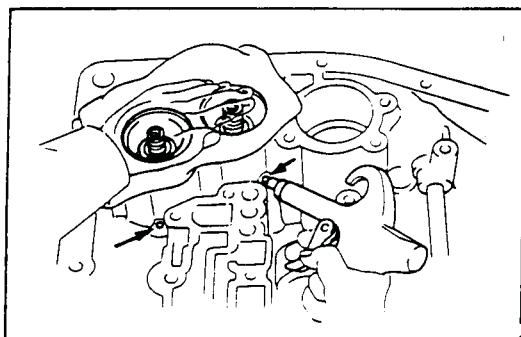

Pop out pistons for C₂ and B₂ into a rag, using low-pressure compressed air (1 kg/cm², 14 psi or 98 kPa). Force air into the holes shown and remove the pistons and springs.

Remove the O-rings from the pistons.

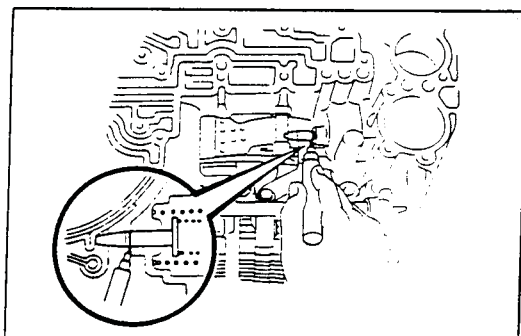

MEASURE PISTON STROKE OF SECOND COAST BRAKE

Apply a small amount of paint to the piston rod at the point it meets the case as shown in the illustration.



Technical Service Information

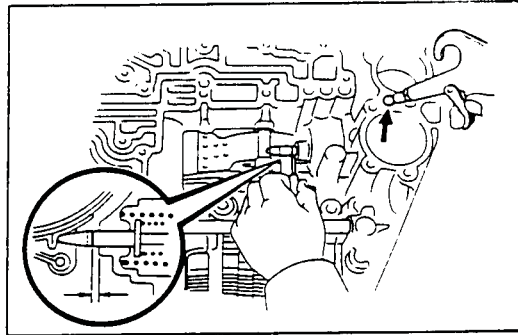

Using SST, measure the piston stroke applying and releasing the compressed air (4 – 8 kg/cm², 57 – 114 psi or 392 – 785 kPa) as shown.

SST 09240-00020

Piston stroke: 2.0 – 3.5 mm (0.079 – 0.138 in.)

If the piston stroke exceed the limit, inspect the brake band.

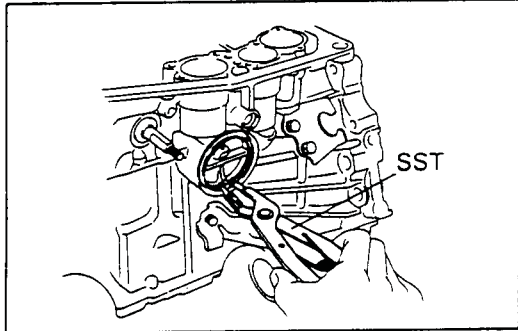

REMOVE SECOND COAST BRAKE PISTON

Using SST, remove the snap ring.

SST 09350-32014 (09351-32050)

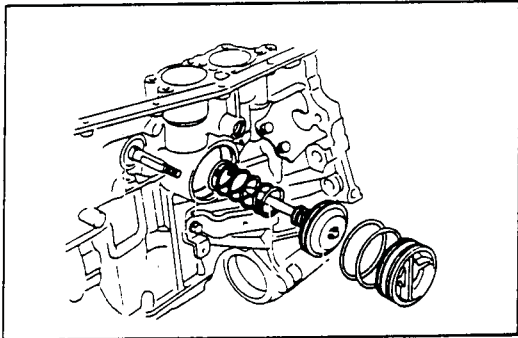

Remove the cover.

Remove the piston and outer return spring.

Remove the two O-rings from the cover.

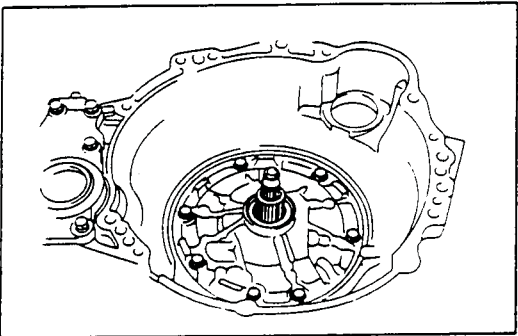

STAND TRANSAXLE ENGINE SIDE UPWARD

REMOVE OIL PUMP

CAUTION: Before remove the oil pump, remove the second coast brake piston.

Remove the seven bolts.

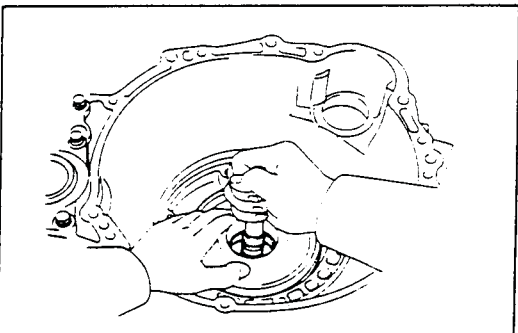

REMOVE DIRECT CLUTCH AND FORWARD CLUTCH



Technical Service Information

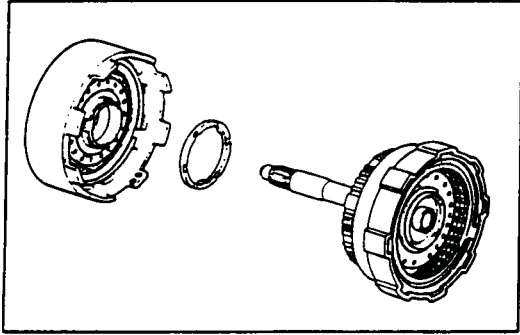

SEPARATE DIRECT CLUTCH AND FORWARD CLUTCH

Separate the direct clutch and forward clutch.
Remove the thrust washer from direct clutch.

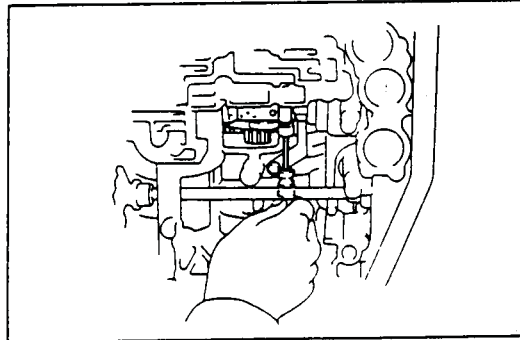

REMOVE SECOND COAST BRAKE BAND

Push the pin with a small screwdriver and remove it from the bolt hole of the oil pump mounting.
Remove the brake band.

NOTE: The method of inspection, refer to page

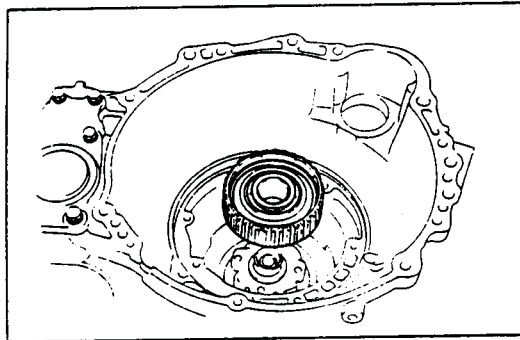

REMOVE FRONT PLANETARY RING GEAR

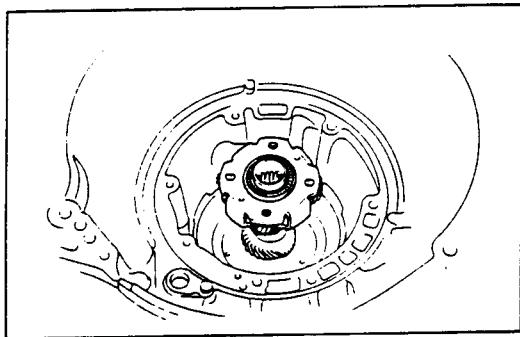

REMOVE FRONT PLANETARY GEAR

Remove the front planetary gear.

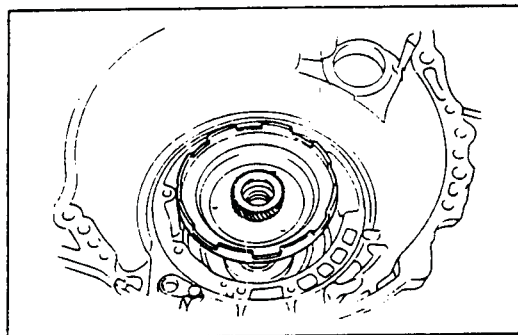

REMOVE SUN GEAR AND SUN GEAR INPUT DRUM

Remove the sun gear and sun gear input drum.



Technical Service Information

Remove the thrust washer from sun gear input drum.

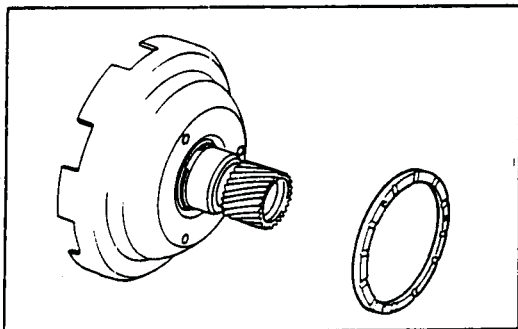

REMOVE SECOND BRAKE DRUM

Remove the snap ring.

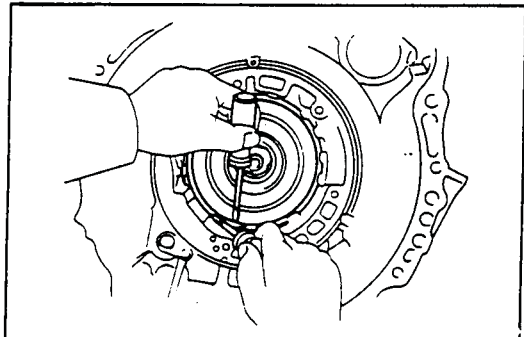

Remove the second brake drum.

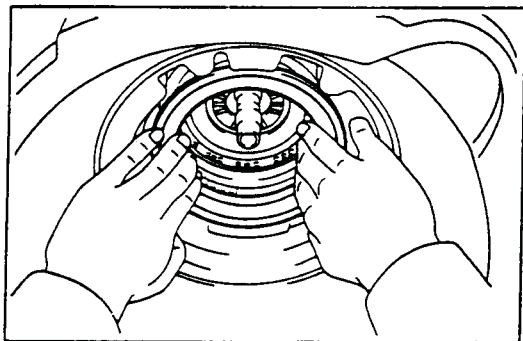

REMOVE SECOND BRAKE PISTON RETURN SPRING

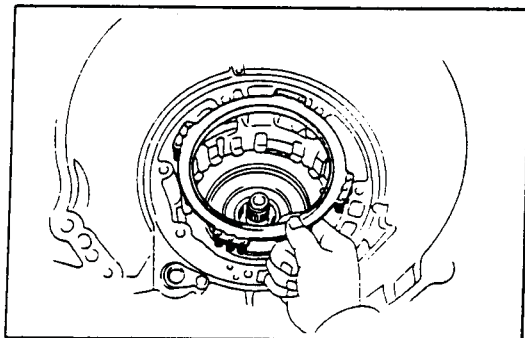

REMOVE NO. 1 ONE-WAY CLUTCH

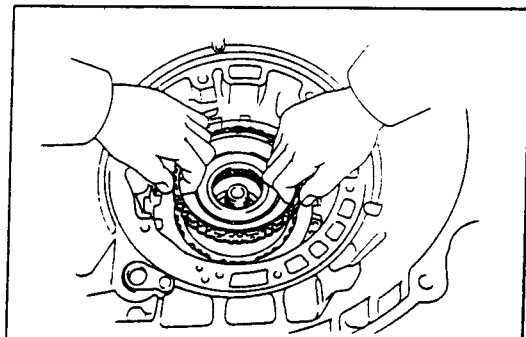



Technical Service Information

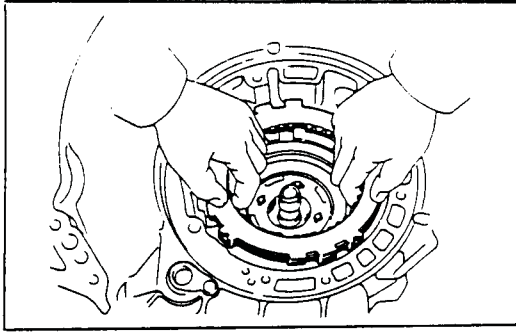

REMOVE PLATES, DISCS AND FLANGE

NOTE: The method of inspection

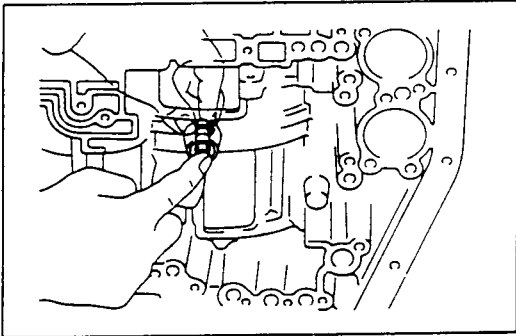

REMOVE SECOND BRAKE DRUM GASKET

Remove the gasket.

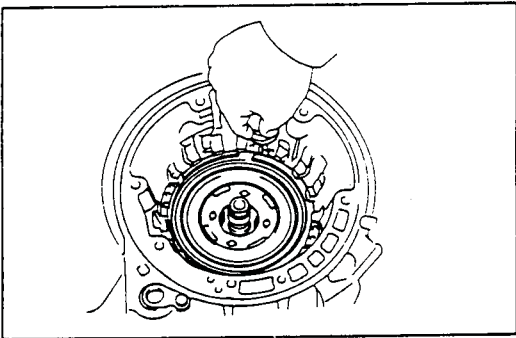

REMOVE NO. 2 ONE-WAY CLUTCH AND REAR PLANETARY GEAR

Remove the snap ring.

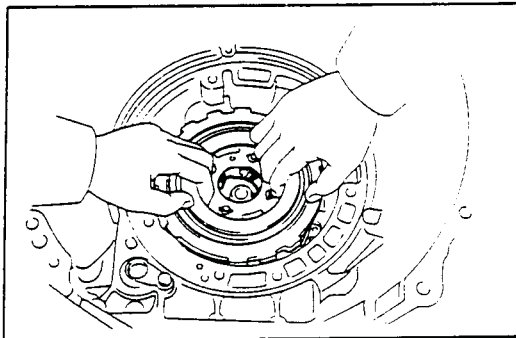

Remove the No.2 one-way clutch and rear planetary gear.

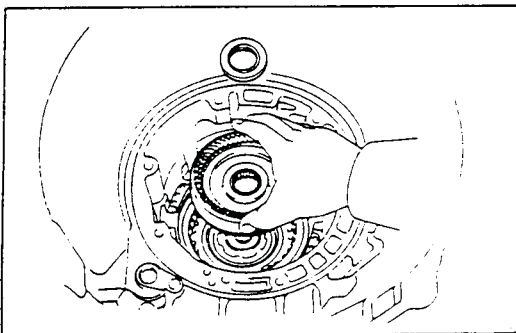

REMOVE REAR PLANETARY RING GEAR

Remove the rear planetary ring gear.

Remove the bearing from the ring gear.



Technical Service Information

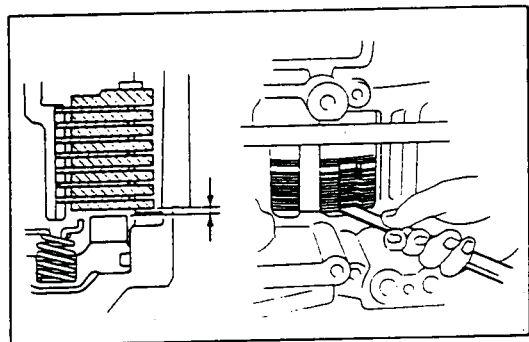

Using a filler gauge, check the pack clearance of the first and reverse brake.

Clearance: 0.85 – 2.05 mm (0.033 – 0.081 in.)

If the pack clearance is not in the specification, disassemble and inspect.

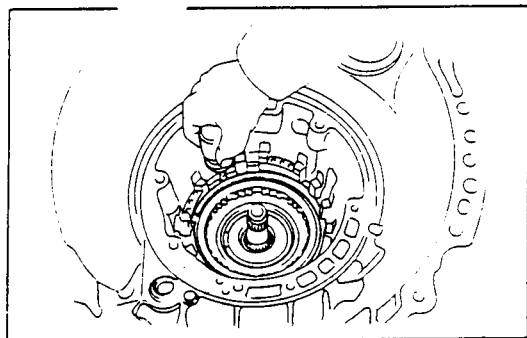

REMOVE FLANGE, DISCS AND PLATES OF FIRST AND REVERSE BRAKE

Remove the snap ring.

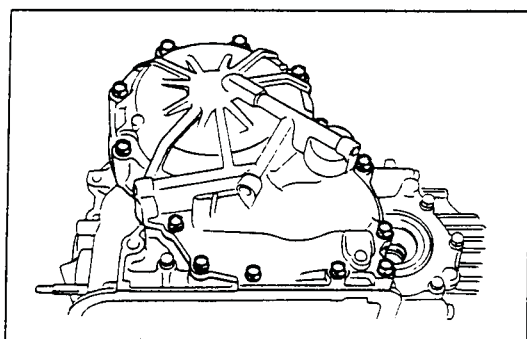

TURN TRANSAXLE CASE AROUND

REMOVE OVERDRIVE UNIT

Remove the thirteen bolts.

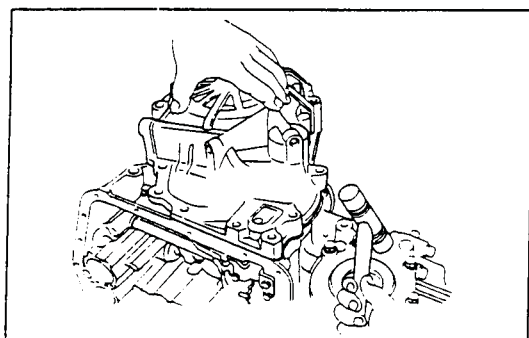

Tap on the circumference of the overdrive case with a plastic hammer to remove the overdrive case.

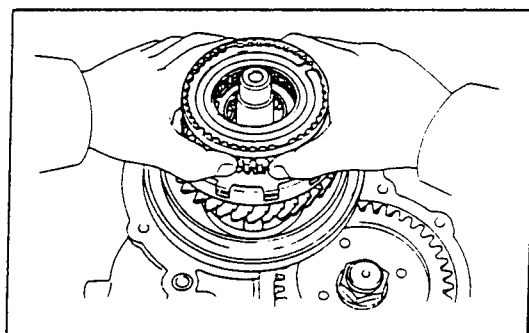

Remove the overdrive planetary gear from transaxle case.



Technical Service Information

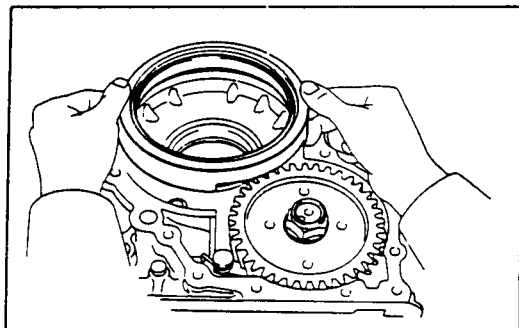

Remove the overdrive brake drum from the transaxle case.

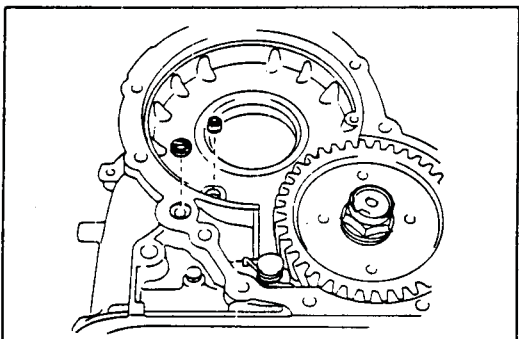

Remove the overdrive clutch apply gasket and overdrive brake apply gasket.

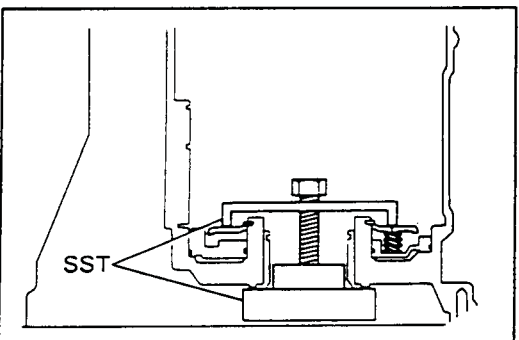

REMOVE FIRST AND REVERSE BRAKE PISTON

Remove the piston return spring.

- Place SST, and compress the return spring evenly by tightening the bolt gradually.

SST 09350-32014 (09351-32040)

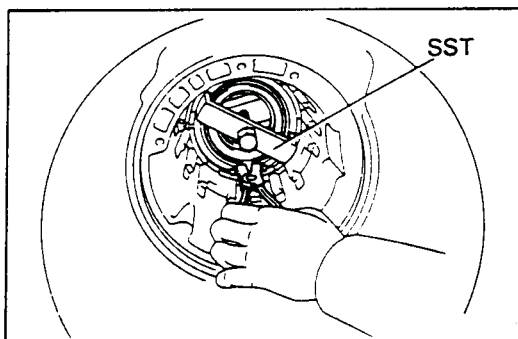

- Using snap ring pliers, remove the snap ring.
- Remove SST.
- Remove the return spring from the case.

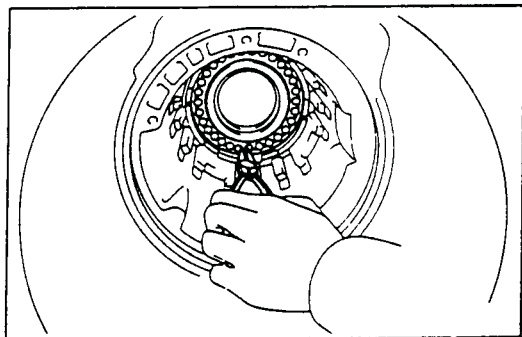

If the piston does not pop out with compressed air, use needle-nose pliers to remove it.



Technical Service Information

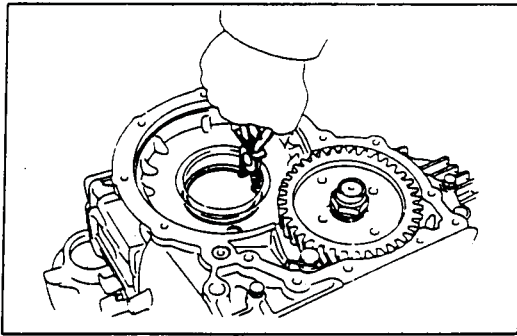

REMOVE SNAP RING FROM TRANSAXLE CASE

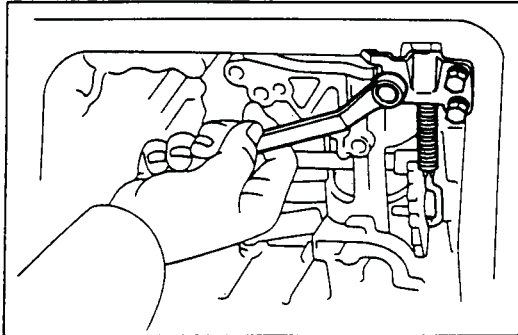

REMOVE PARKING LOCK PAWL BRACKET

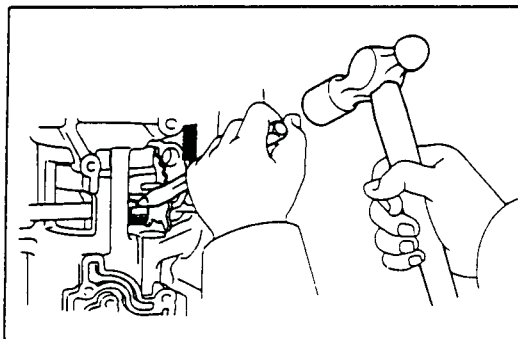

REMOVE MANUAL VALVE SHAFT

Using a cold chisel and hammer, cut the collar.

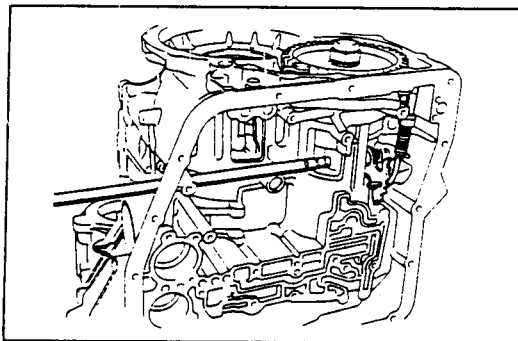

Slide out the shaft from the transaxle case and remove the manual valve lever and parking lock rod.

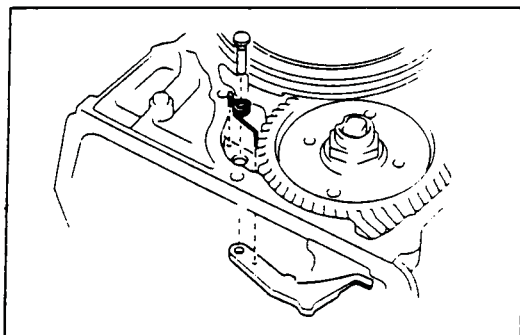

REMOVE PIN, SPRING AND PARKING LOCK PAWL



Technical Service Information

REMOVAL OF DIFFERENTIAL COMPONENT PARTS

MEASURE DIFFERENTIAL TOTAL PRELOAD

Using a torque meter, measure the total preload, and make a note of it.

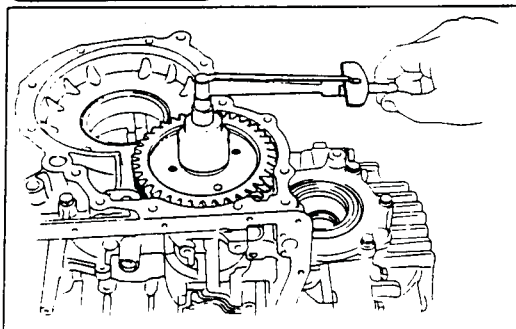

REMOVE LH BEARING RETAINER

Remove the six bolts.

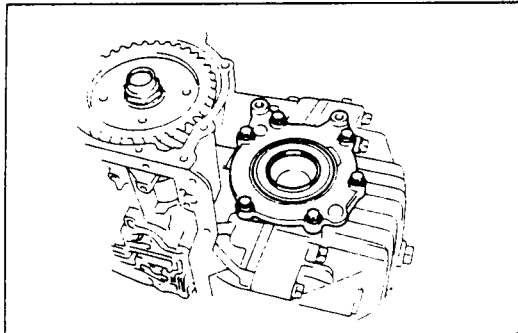

Using a large screwdriver, remove the LH bearing retainer.

CAUTION: Wrap the screwdriver in a rag, etc. to avoid damage to the case and retainer.

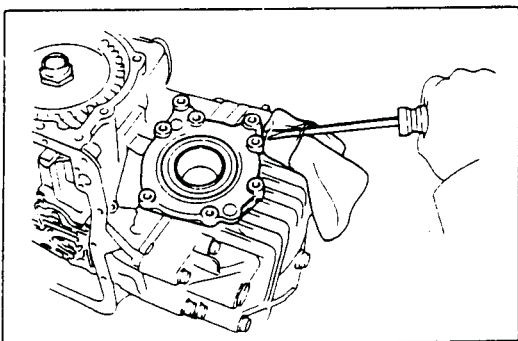

REMOVE RH RETAINER

Remove the six bolts.

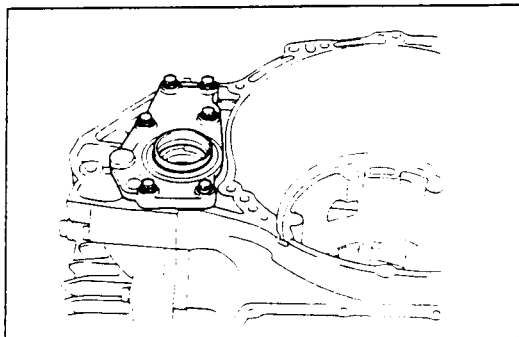

Using a large screwdriver, remove the RH retainer.

CAUTION: Wrap the screwdriver in a rag, etc. to avoid damage to the case and retainer.

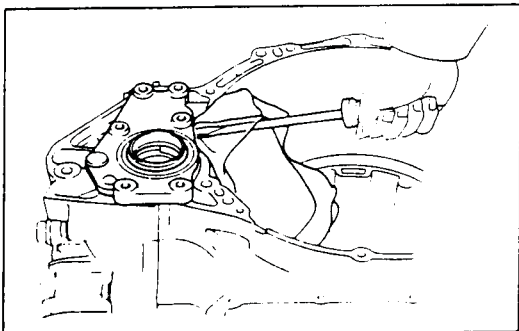



Technical Service Information

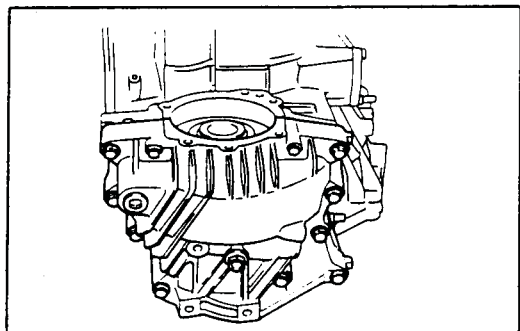

REMOVE CARRIER COVER

Remove the eleven bolts.

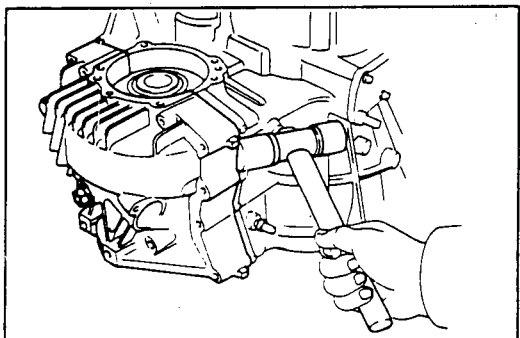

Tap the carrier cover with a plastic hammer to remove it.

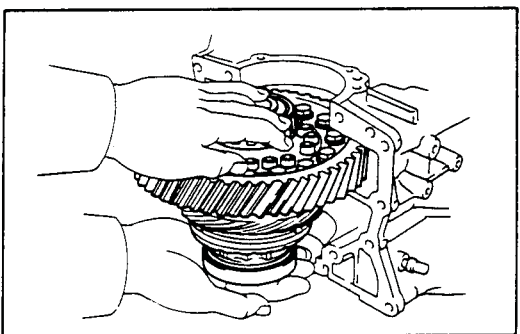

REMOVE DIFFERENTIAL CASE

Remove the differential case, outer race and shim from the transaxle case.

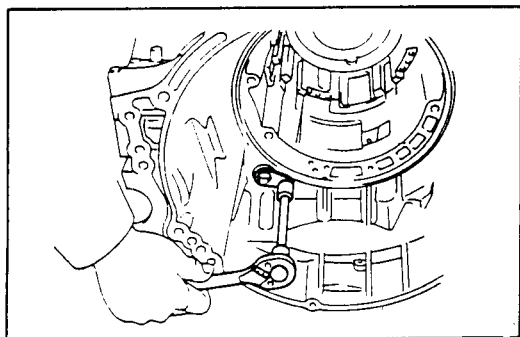

REMOVE DRIVE PINION CAP

Remove the bolt.

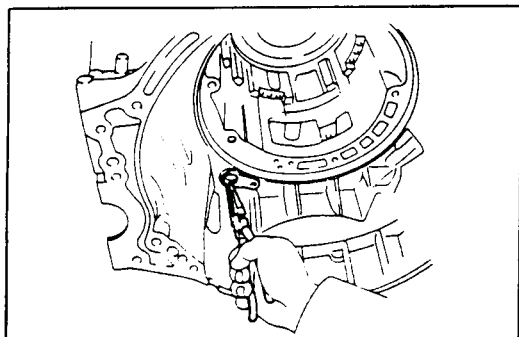

Using pliers, pull out the drive pinion cap.
Remove the O-ring from the cap.



Technical Service Information

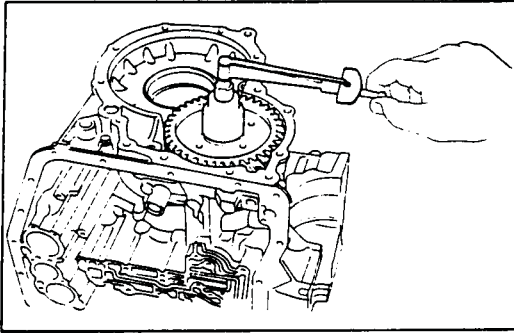

MEASURE DRIVE PINION PRELOAD

Using a torque meter, measure the drive pinion preload.

Preload (at starting): Reused bearing

5 – 8 kg-cm (4.3 – 6.9 in.-lb, 0.5 – 0.8 N·m)

The total preload measured in step 1 minus the drive pinion preload equals 1.4 – 2.0 kg-cm (1.2 – 1.7 in.-lb, 0.1 – 0.2 N·m). If the result is not within this specification, the side bearing preload is bad.

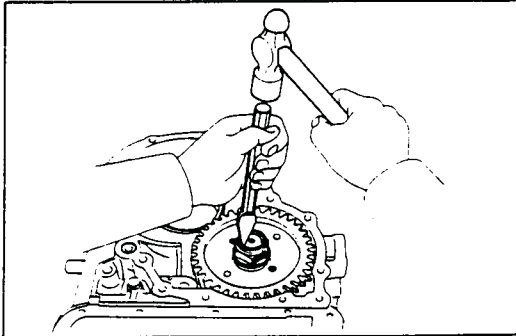

REMOVE COUNTER DRIVEN GEAR

Using a chisel, loosen the staked part of the nut.

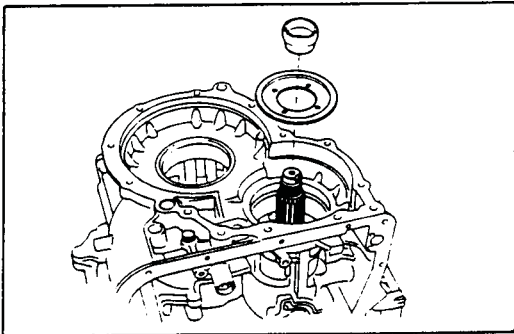

Remove the spacer and oil slinger.

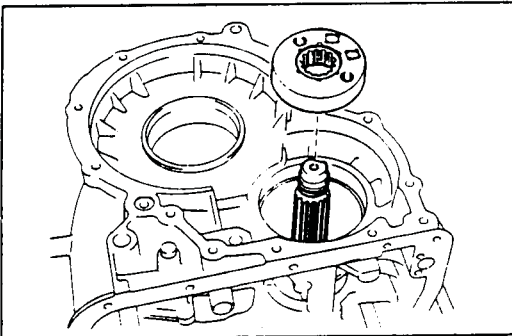

REMOVE SENSOR ROTOR

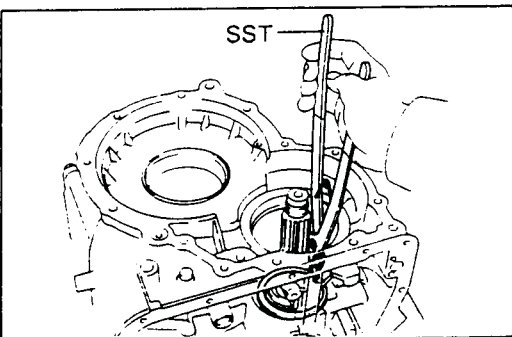

REMOVE DRIVE PINION

Using SST, remove the snap ring.

SST 09350-32014 (09351-32050)

Oil Pump

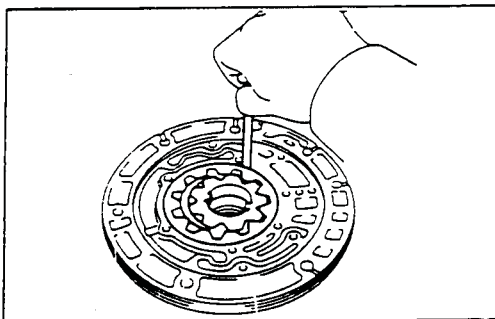
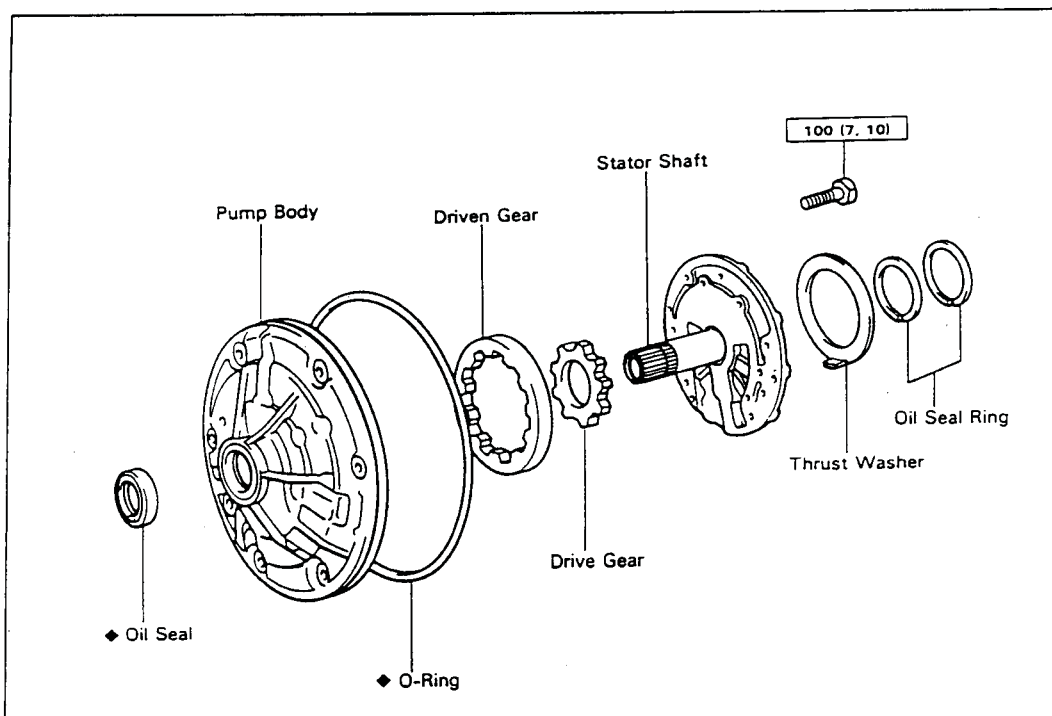

INSPECTION OF OIL PUMP

CHECK BODY CLEARANCE OF DRIVEN GEAR

Push the driven gear to one side of the body.

Using a feeler gauge, measure the clearance.

Standard body clearance: 0.07 – 0.15 mm
(0.0028 – 0.0059 in.)

Maximum body clearance: 0.3 mm (0.012 in.)

If the body clearance is greater than the maximum, replace the oil pump body subassembly.

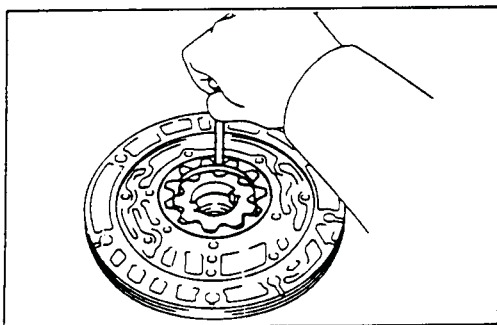

CHECK TIP CLEARANCE OF DRIVEN GEAR

Measure between the driven gear teeth and the crescent-shaped part of the pump body.

Standard tip clearance: 0.11 – 0.14 mm
(0.0043 – 0.0055 in.)

Maximum tip clearance: 0.3 mm (0.012 in.)

If the tip clearance is greater than the maximum, replace the oil pump body subassembly.

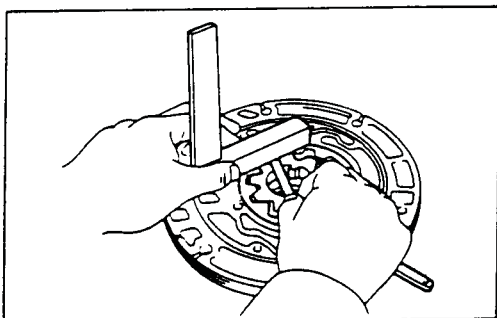

CHECK SIDE CLEARANCE OF BOTH GEARS

Using a steel straightedge and a feeler gauge, measure the side clearance of both gears.

Standard side clearance: 0.02 – 0.05 mm
(0.0008 – 0.0020 in.)

Maximum side clearance: 0.1 mm (0.004 in.)

Second Coast Brake

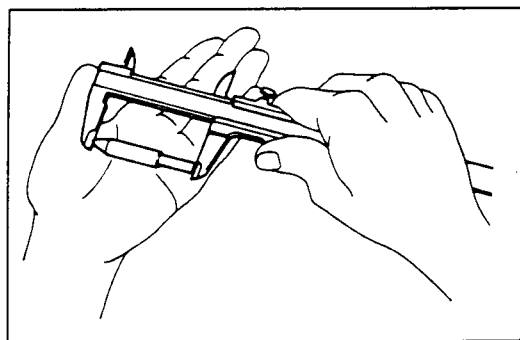
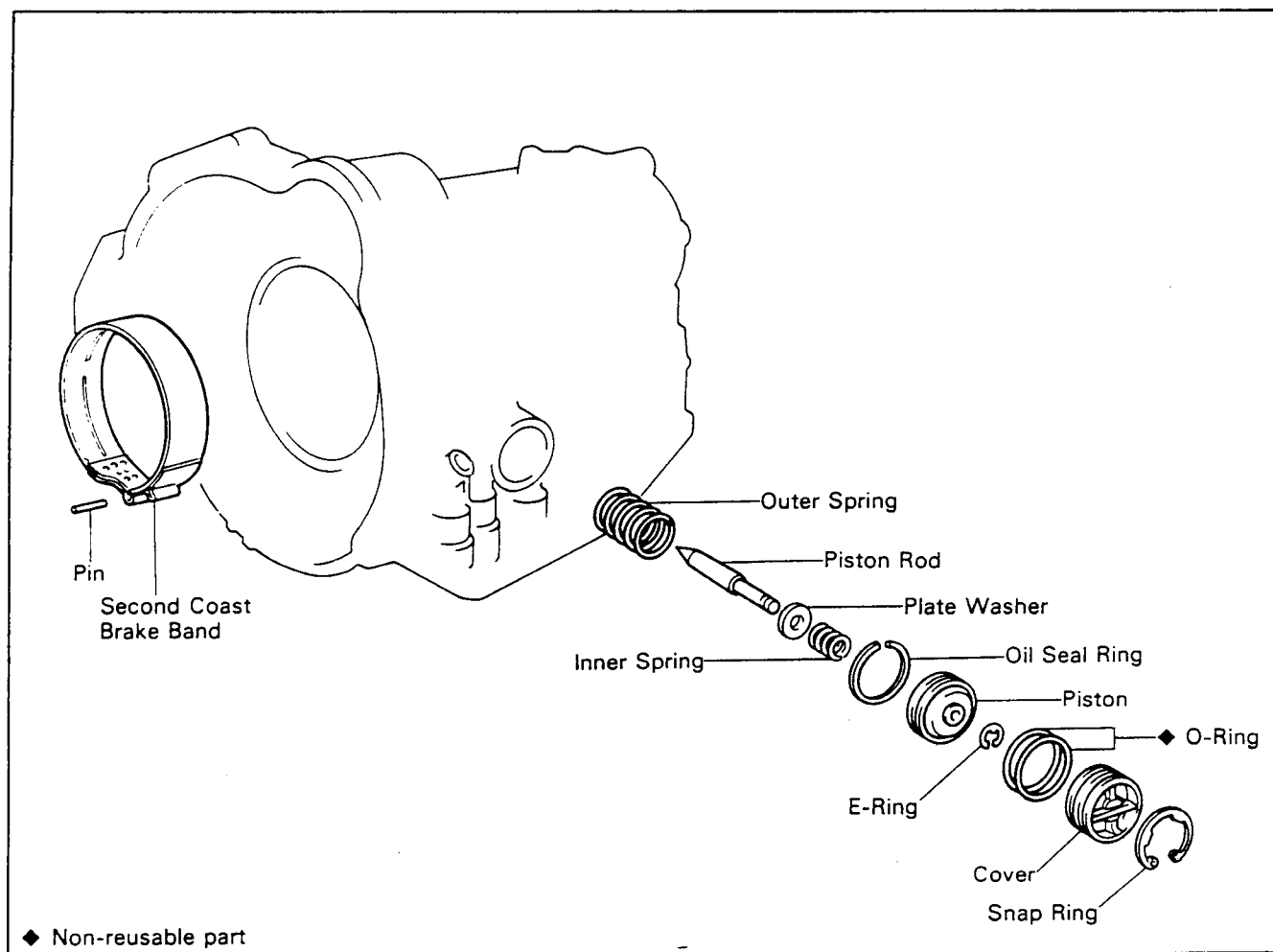

ASSEMBLY OF SECOND COAST BRAKE PISTON

SELECT PISTON ROD

If the band is OK with piston stroke not within the standard value, select the piston rod.

Piston stroke: 2.0 – 3.5 mm (0.079 – 0.138 in.)

There are two lengths of piston rod.

Piston rod length: 95.2 mm (3.748 in.)

96.3 mm (3.791 in.)

INSTALL PISTON ROD

Install the washer and spring to the piston rod.

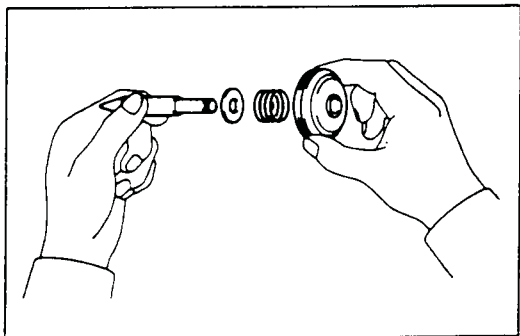



Technical Service Information

Direct Clutch

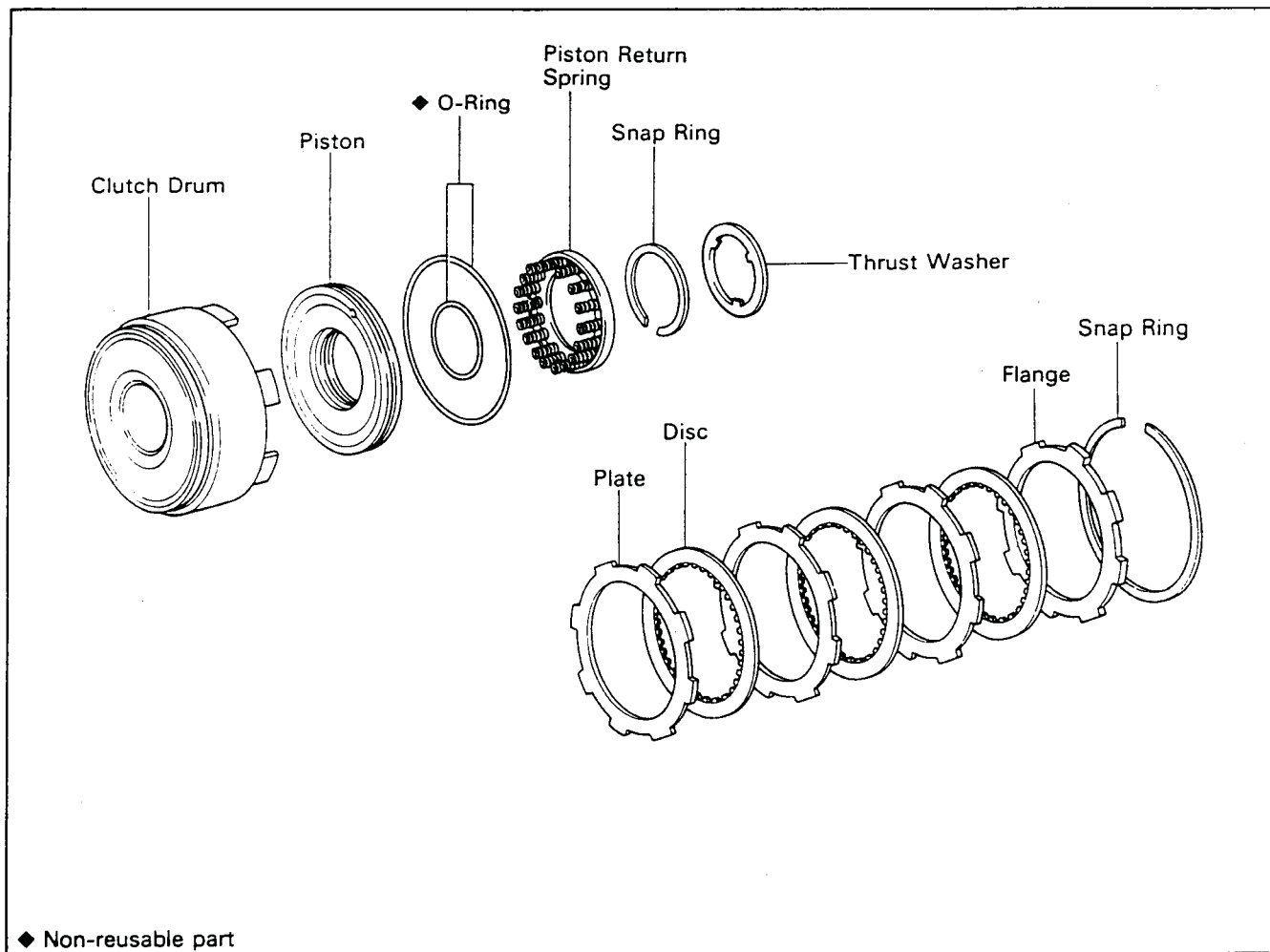

◆ Non-reusable part

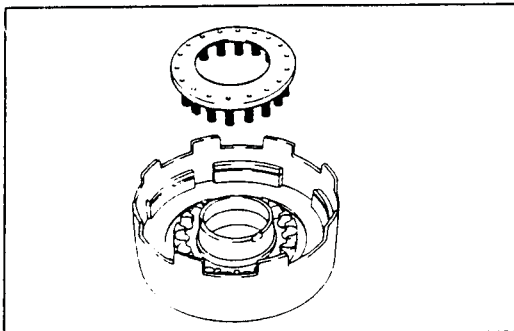
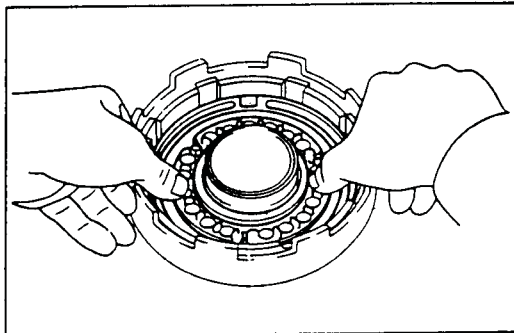

ASSEMBLY OF DIRECT CLUTCH

INSTALL CLUTCH PISTON IN DIRECT CLUTCH DRUM

Install new O-rings to the piston. Coat the O-rings with ATF.

Being careful not to damage the O-rings, press the piston into the drum with the cup side up.

INSTALL PISTON RETURN SPRING

Place the return spring and snap ring onto the piston.

Place SST on the spring retainer, and compress the return spring with a shop press.

SST 09350-32014 (09351-32070)

Install the snap ring with the snap ring pliers. Be sure the end gap of snap ring is not aligned with the spring retainer claw.



Technical Service Information

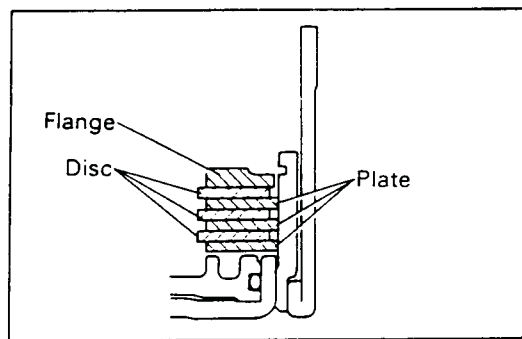

INSTALL PLATES, DISCS AND FLANGE

Install plates and discs.

Install in order: P=Plate D=Disc
P-D-P-D-P-D

Install the flange with facing the flat end downward.

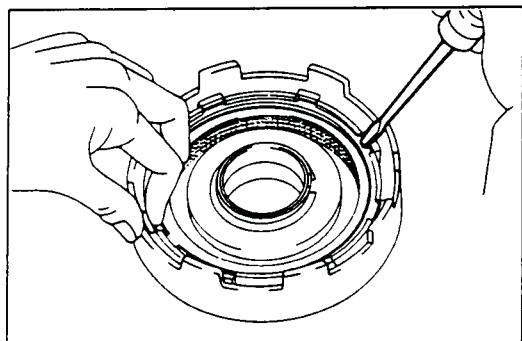

INSTALL SNAP RING

Check that the end gap of the snap ring is not aligned with one of cutouts.

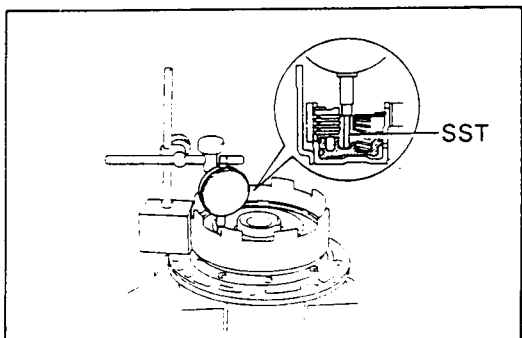

RECHECK PISTON STROKE OF DIRECT CLUTCH

Install the direct clutch on the oil pump.

Using a dial indicator (long type pick or SST), measure the direct clutch piston stroke applying and releasing the compressed air (4 – 8 kg/cm², 57 – 114 psi, 392 – 785 kPa) as shown.

SST 09350-32014 (09351-32190)

Piston stroke: 0.91 – 1.35 mm (0.0358 – 0.0531 in.)

If the piston stroke is nonstandard, select another flange.

NOTE: There are two different thicknesses for flange.

2.70 mm (0.1063 in.)

3.00 mm (0.1181 in.)

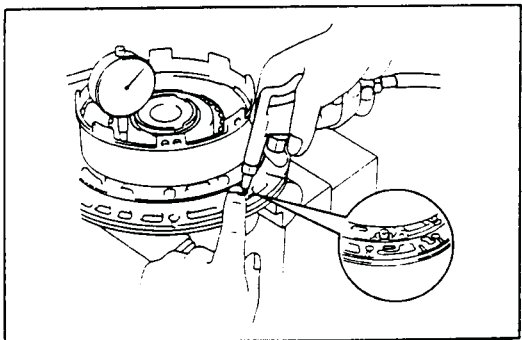

AUTOMATIC TRANSMISSION SERVICE GROUP

Technical Service Information

Forward Clutch

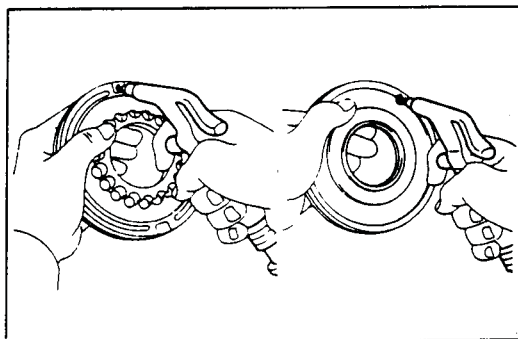
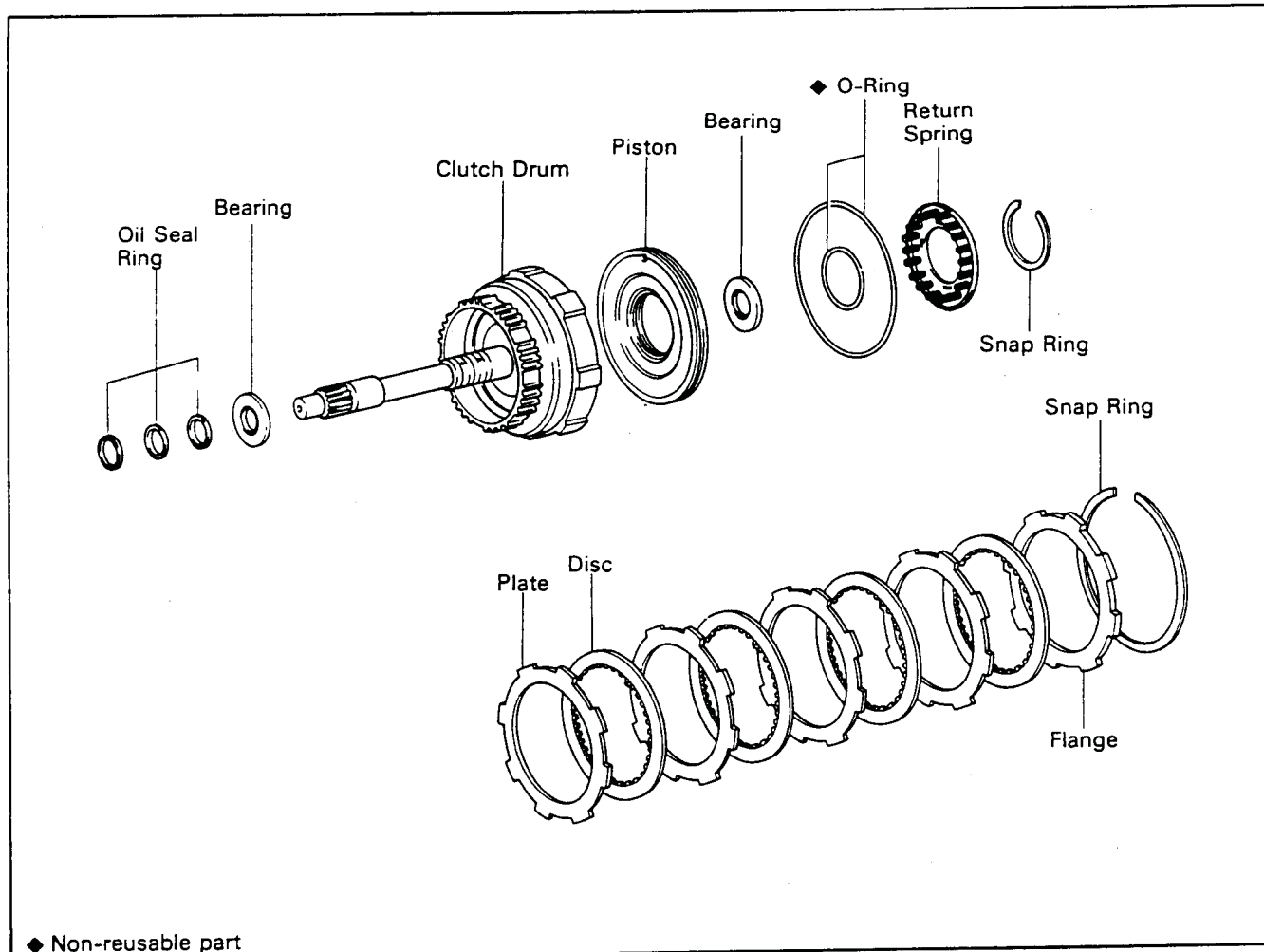

INSPECTION OF FORWARD CLUTCH

INSPECT CLUTCH PISTON

Check that the check ball is free by shaking the piston.

Check that valve does not leak by applying low-pressure compressed air.

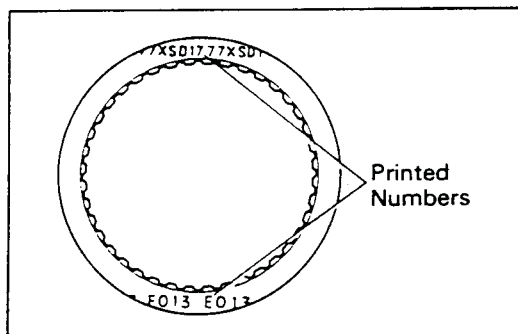

INSPECT DISCS, PLATES AND FLANGE

Check that the sliding surfaces of discs, plates and flange are worn or burnt. If necessary, replace them.

NOTE:

- If the lining of the disc is exfoliated or discolored, or even a part of the printed numbers are defaced, replace all discs.
- Before assembling new discs, soak them in ATF for at least fifteen minutes.



Technical Service Information

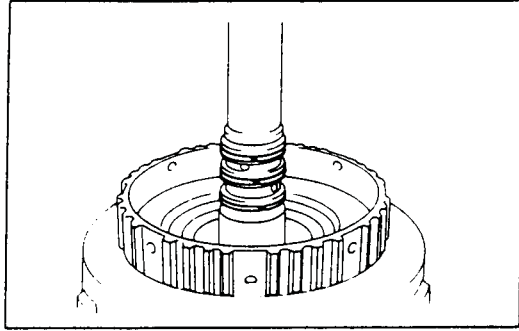

ASSEMBLY OF FORWARD CLUTCH

INSTALL OIL SEAL RINGS

Install the three oil seal rings to the shaft.

CAUTION: Do not spread the ring ends more than necessary.

NOTE: After installing the oil seal rings, check that they move smoothly.

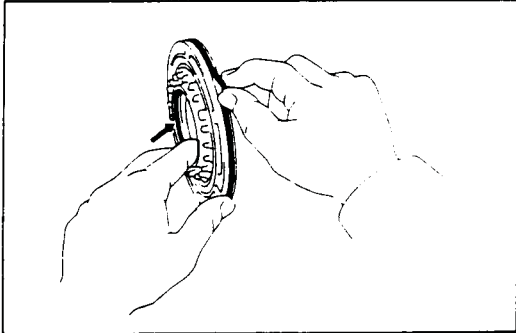

INSTALL CLUTCH PISTON TO CLUTCH DRUM

Install the two new O-rings to the piston.

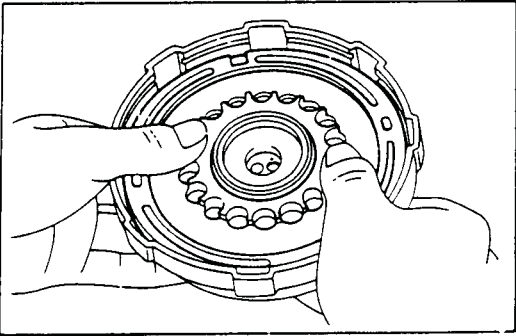

Coat the O-rings with ATF.

Press the piston into the drum with the cup side up, being careful not to damage the O-rings.

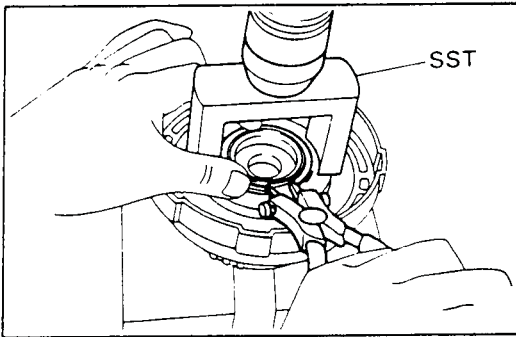

INSTALL PISTON RETURN SPRINGS

Place the return spring and snap ring onto the piston.

Place SST on the spring retainer, and compress the springs with a shop press.

SST 09350-32014 (09351-32070)

Install the snap ring with snap ring pliers.

Be sure the end gap of snap ring is not aligned with the spring retainer claw.

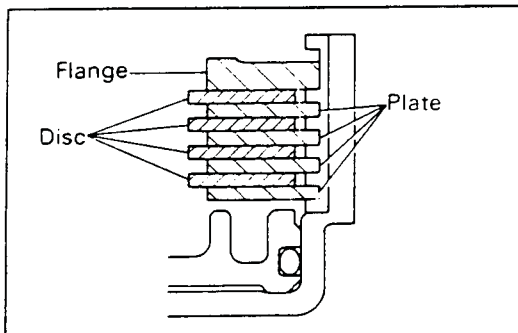

INSTALL PLATES, DISCS AND FLANGE

Install the plates and discs.

Install in order: P=Plate D=Disc
P-D-P-D-P-D-P-D

Install the flange with facing the flat end downward.

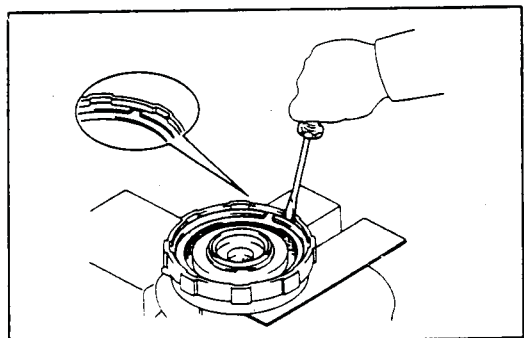
**INSTALL SNAP RING**

Check that the end gap of snap ring is not aligned with one of the cutouts.

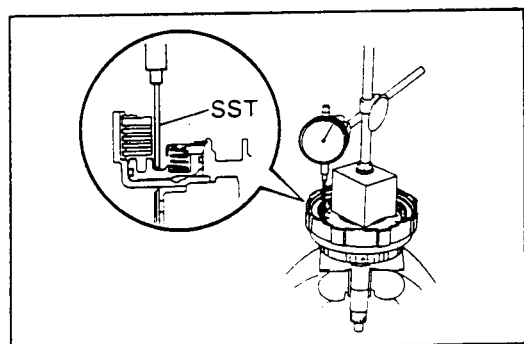
**RECHECK PISTON STROKE OF FORWARD CLUTCH**

Using a dial indicator (long type pick or SST), measure the forward clutch piston stroke applying and releasing the compressed air (4 – 8 kg/cm², 57 – 114 psi, 392 – 785 kPa) as shown.

SST 09350-32014 (09351-32190)

Piston stroke: 1.41 – 1.82 mm
(0.0555 – 0.0717 in.)

If the piston stroke is nonstandard, select another flange.

NOTE: There are two different thicknesses for flange.

Flange thickness: 3.00 mm (0.1181 in.)
3.37 mm (0.1327 in.)

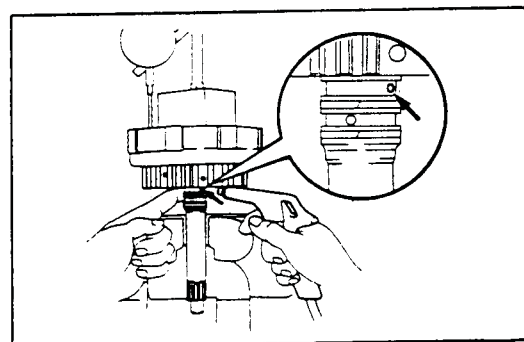

Front Planetary Gear

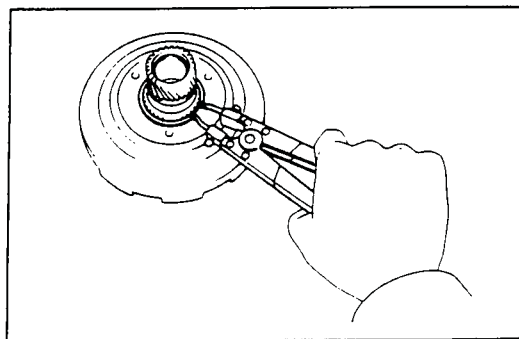
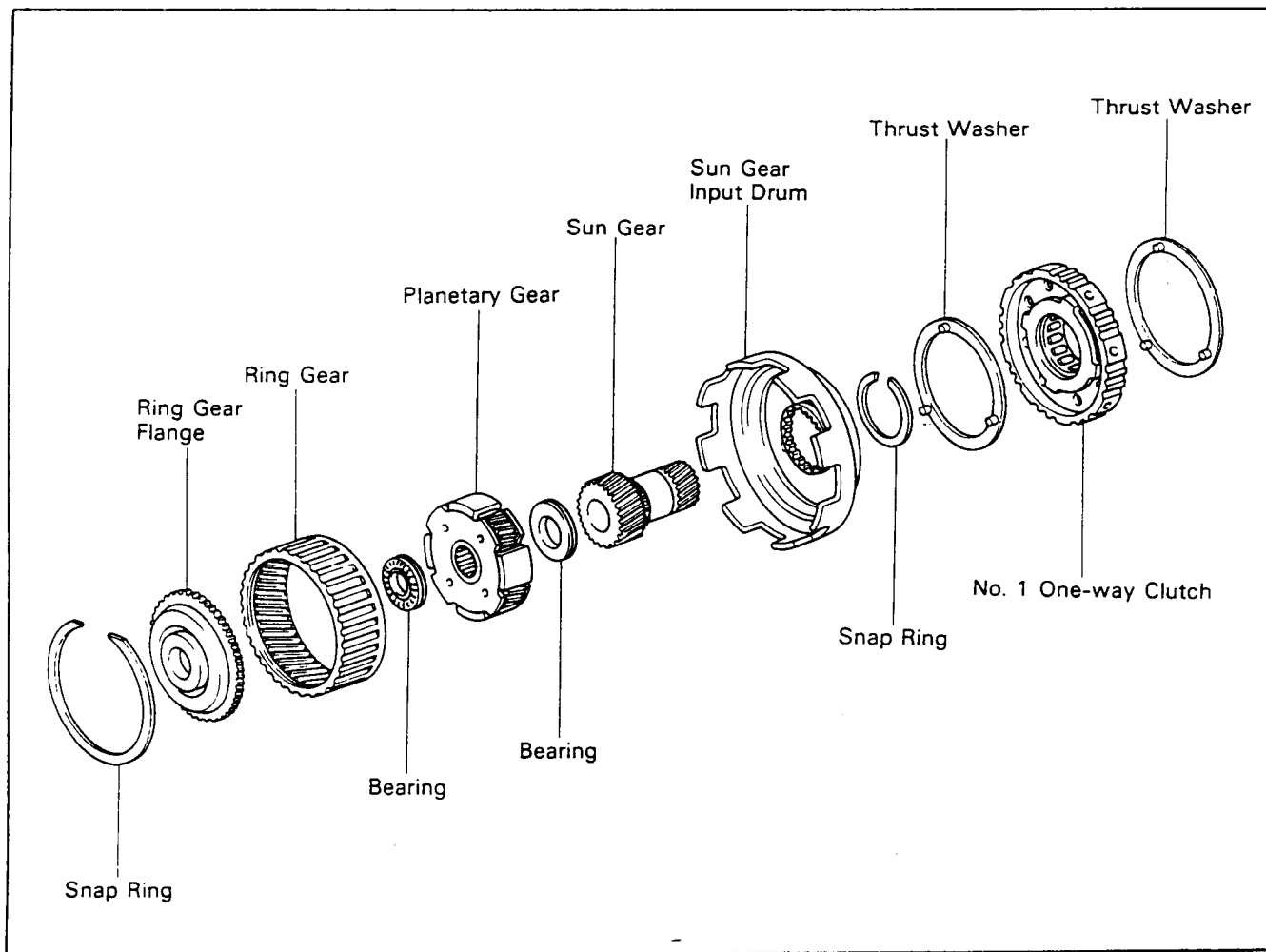

ASSEMBLY OF ONE-WAY CLUTCH AND SUN GEAR

INSTALL SUN GEAR TO DRUM

Install the sun gear to the drum.

Using the snap ring pliers, install the snap ring to drum.

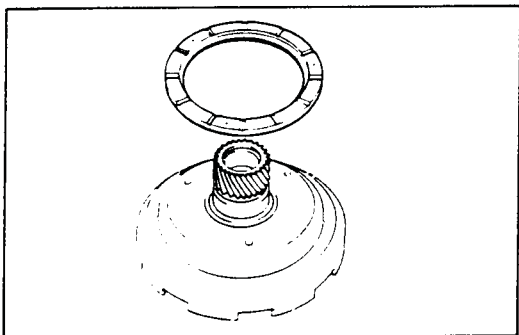

INSTALL THRUST WASHER TO SUN GEAR INPUT DRUM

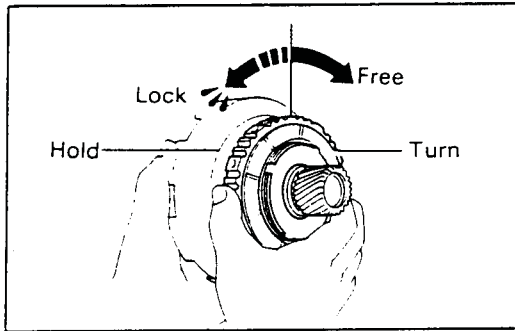
**INSTALL NO. 1 ONE-WAY CLUTCH AND SECOND BRAKE HUB ON SUN GEAR**

While turning the hub clockwise, slide the one-way clutch onto the sun gear.

RECHECK OPERATION OF ONE-WAY CLUTCH

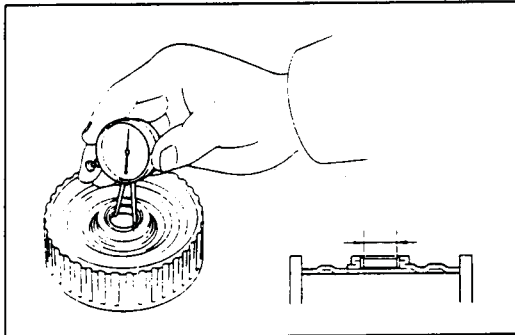
**INSPECTION OF PLANETARY RING GEAR****INSPECT RING GEAR FLANGE BUSHING**

Using a dial indicator, measure the inside diameter of the flange bushing.

Maximum inside diameter: 30.08 mm (1.1842 in.)

If the inside diameter is greater than the maximum, replace the flange.

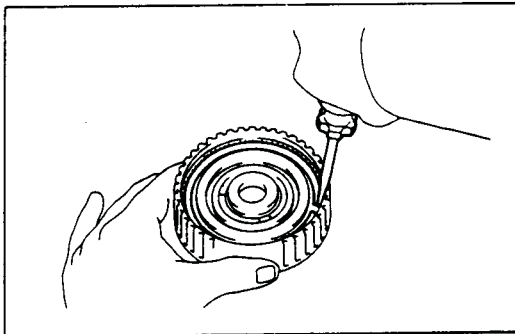
**REMOVE RING GEAR FLANGE**

Using a screwdriver, remove the snap ring.

Remove the flange from the ring gear.

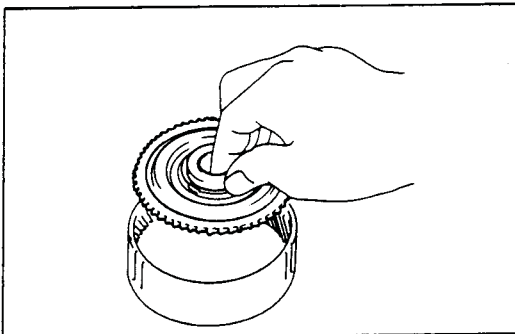
**INSTALL RING GEAR FLANGE**

Position the flange into the ring gear.

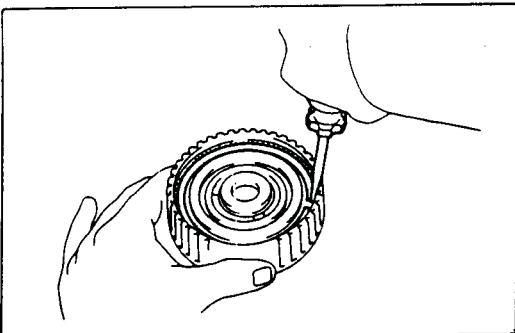

Using a screwdriver, install the snap ring.



Technical Service Information Second Brake

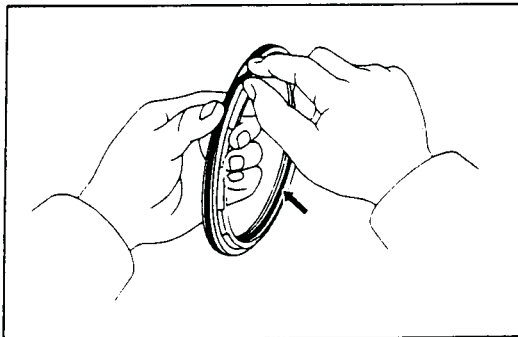
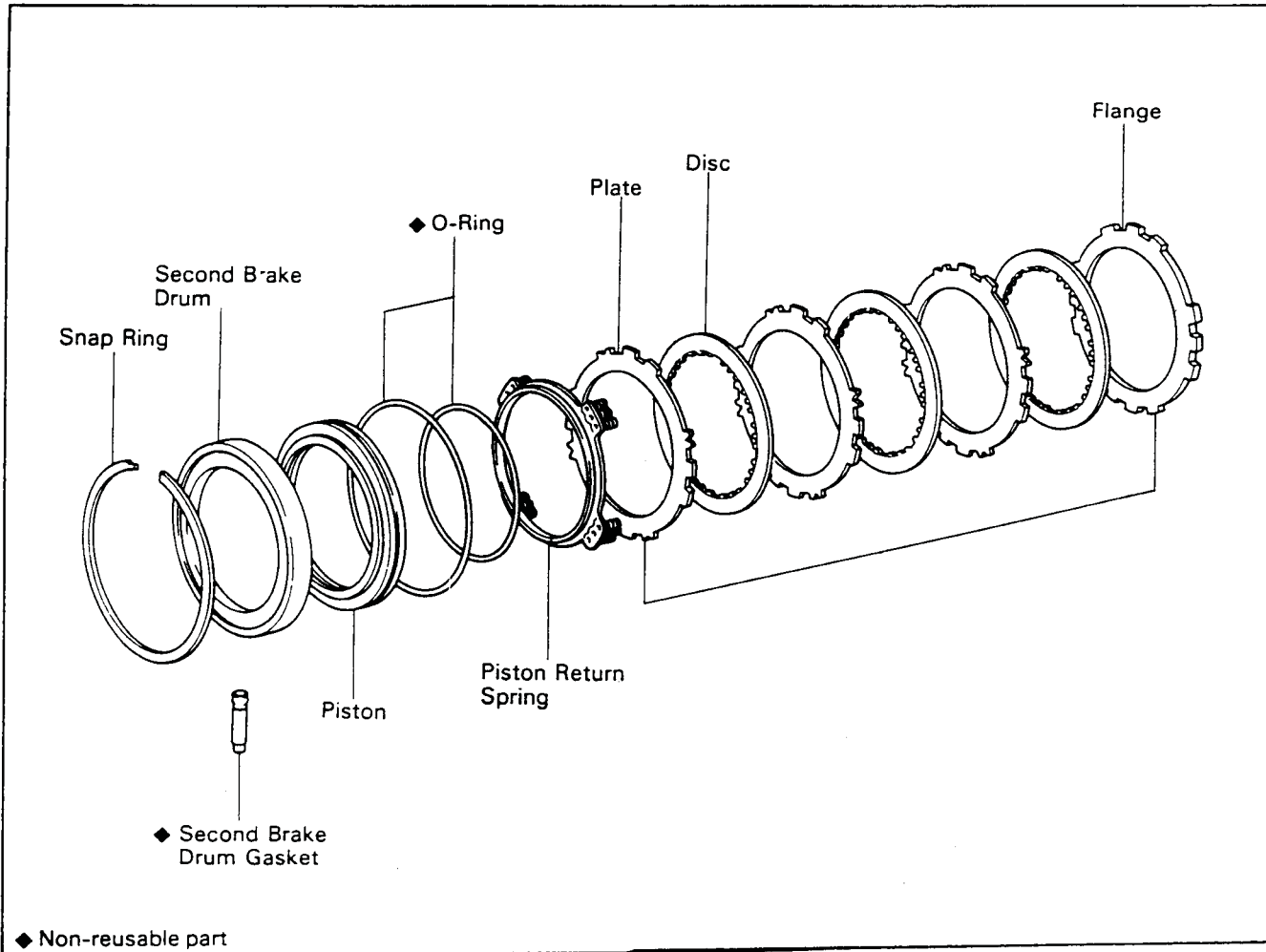

ASSEMBLY OF SECOND BRAKE PISTON

INSTALL PISTON

Coat a new O-ring with ATF.
Install the two O-rings on the piston.

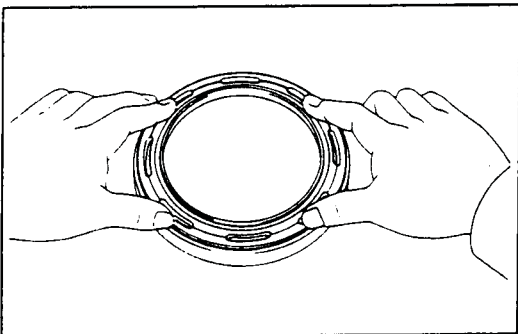

Press the piston into the drum, being careful not to damage the O-rings.

Technical Service Information

Rear Planetary Gear

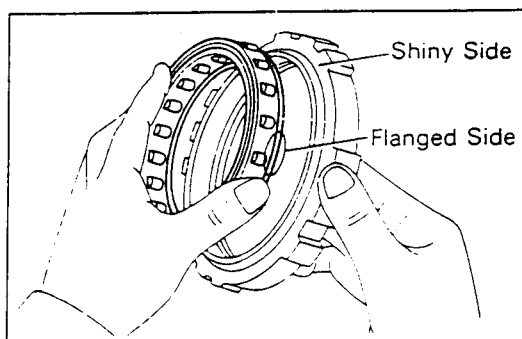
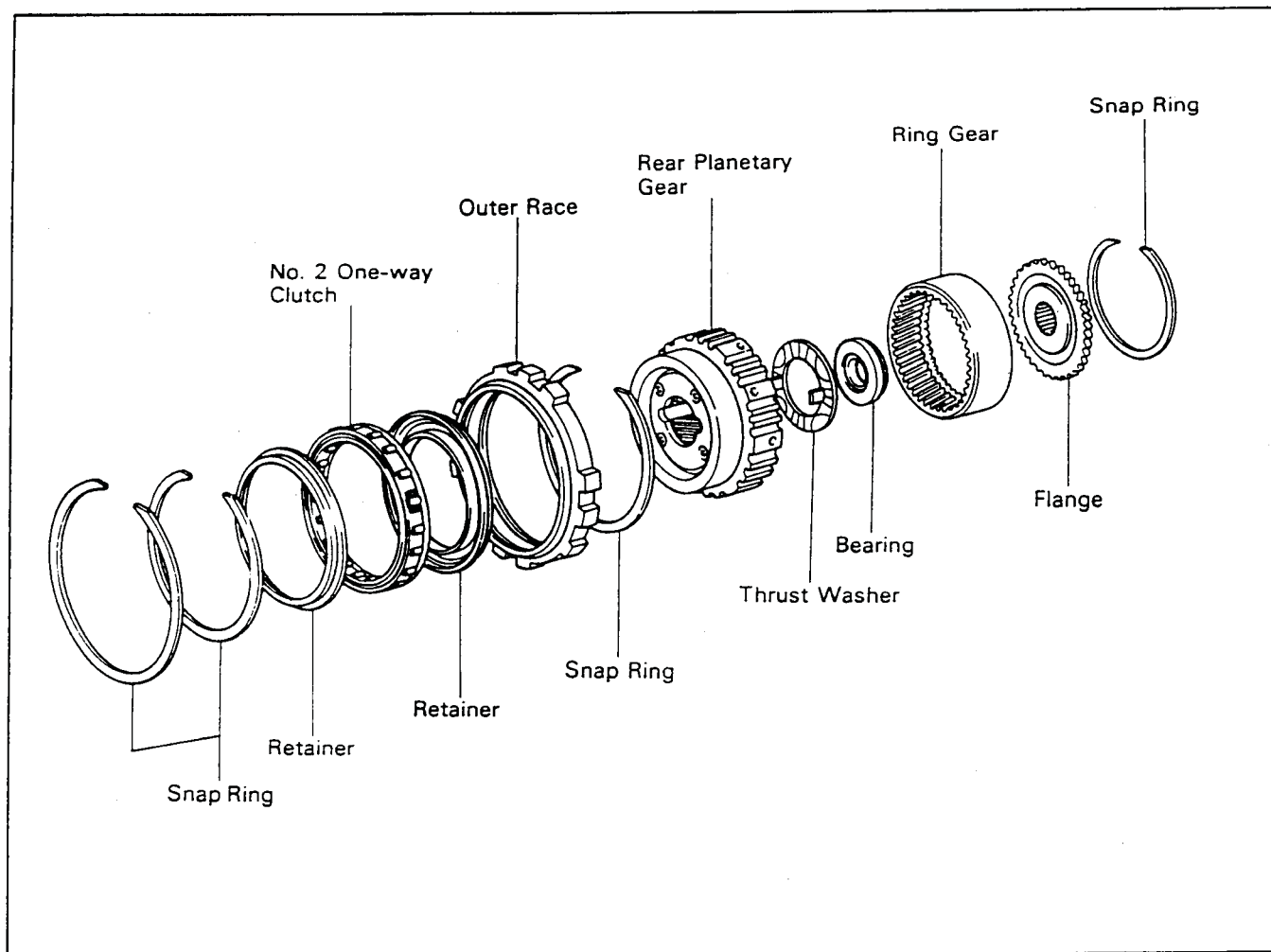

ASSEMBLY OF ONE-WAY CLUTCH

Install the one-way clutch into the outer race, facing the flanged side of one-way clutch toward the shiny side of outer race.

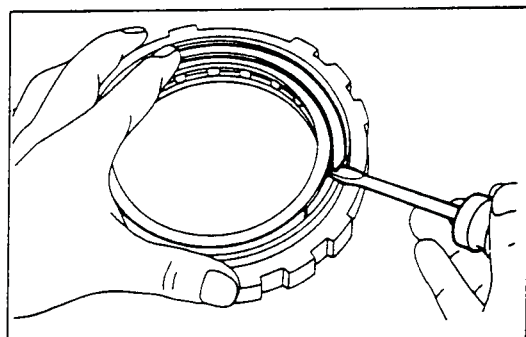

Install the two retainers and snap rings to the both sides.



Technical Service Information

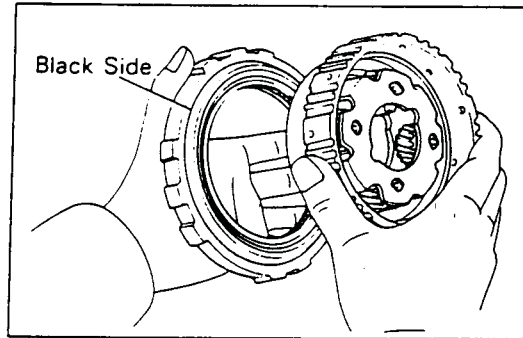

INSTALL PLANETARY GEAR INTO ONE-WAY CLUTCH

Install the planetary gear into the one-way clutch, facing the inner race of the planetary gear toward the black side of the one-way clutch outer race.

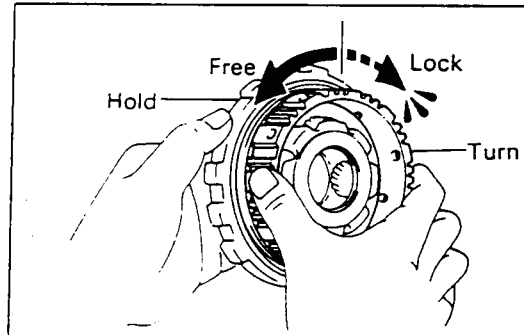

CHECK OPERATION OF ONE-WAY CLUTCH

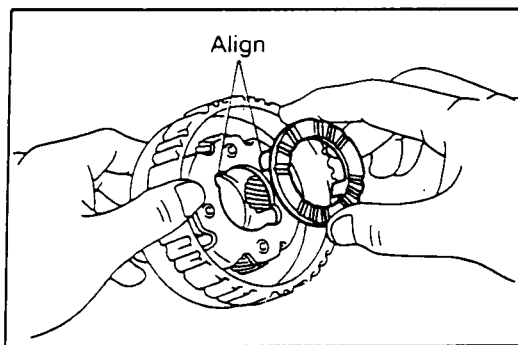

INSTALL THRUST WASHER

Coast the thrust washer with petroleum jelly.

Align the tab of the washer with the hollows of the carrier.

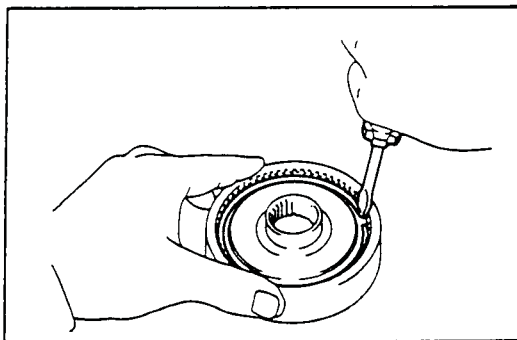

REPLACEMENT OF RING GEAR FLANGE

REMOVE RING GEAR FLANGE

Using a screwdriver, remove the snap ring.

Remove the flange from the ring gear.

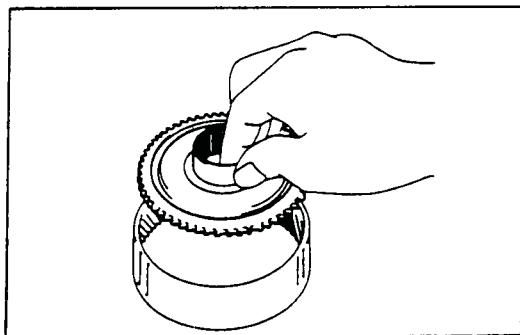

INSTALL RING GEAR FLANGE

Position the flange into the ring gear.

First and Reverse Brake

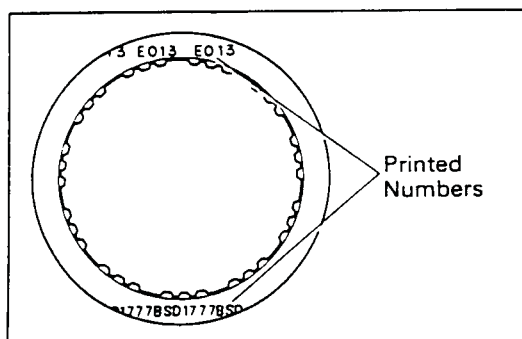
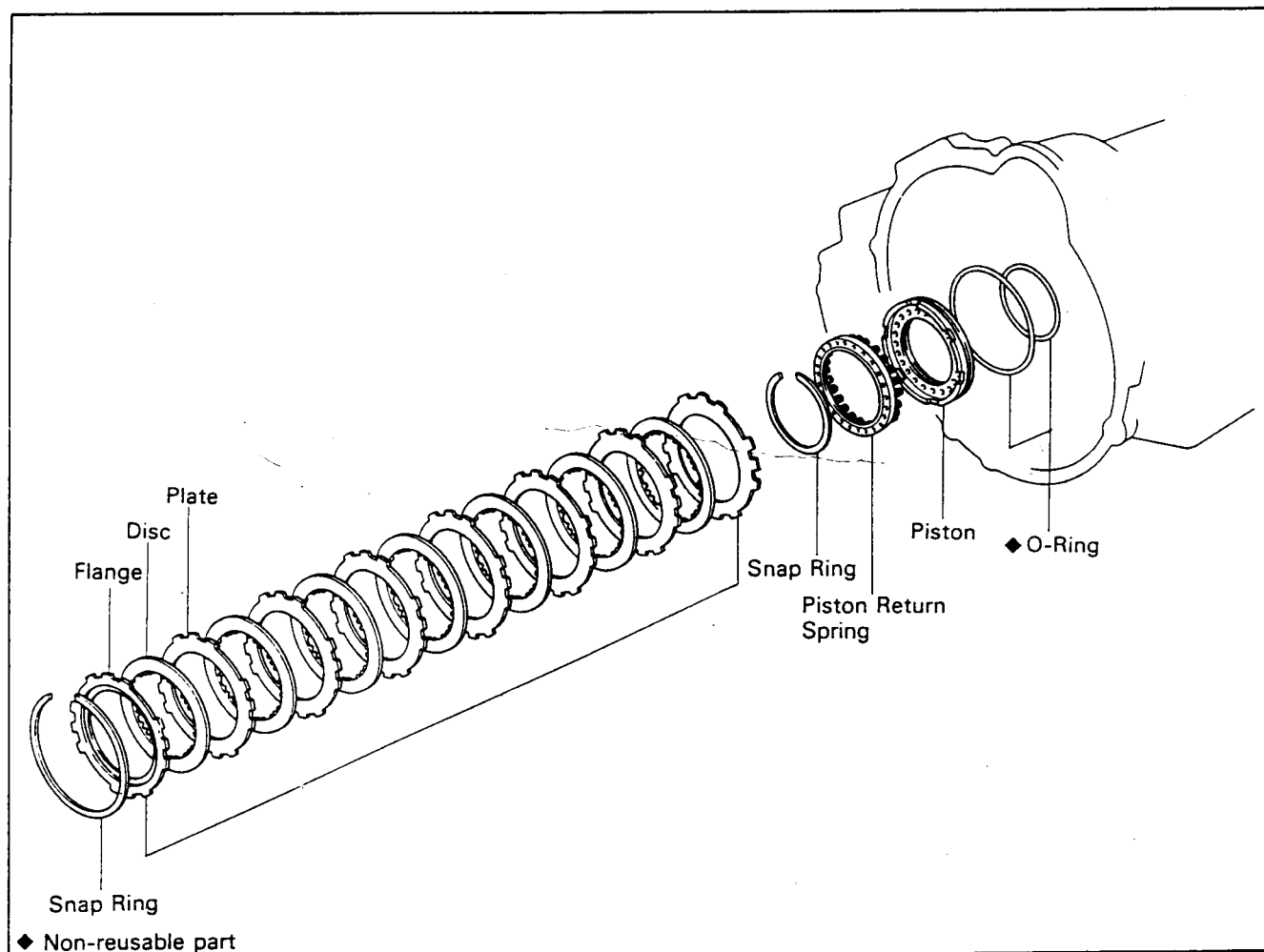

INSPECTION OF FIRST AND REVERSE BRAKE COMPONENT

INSPECT DISCS, PLATES AND FLANGES

Check that the sliding surfaces of discs, plates and flanges are worn or burnt. If necessary, replace them.

NOTE:

- If the lining of the disc is exfoliated or discolored, or even a part of the printed numbers are defaced, replace all discs.
- Before assembly new discs, soak them in ATF for at least fifteen minutes.



Technical Service Information

Overdrive Unit

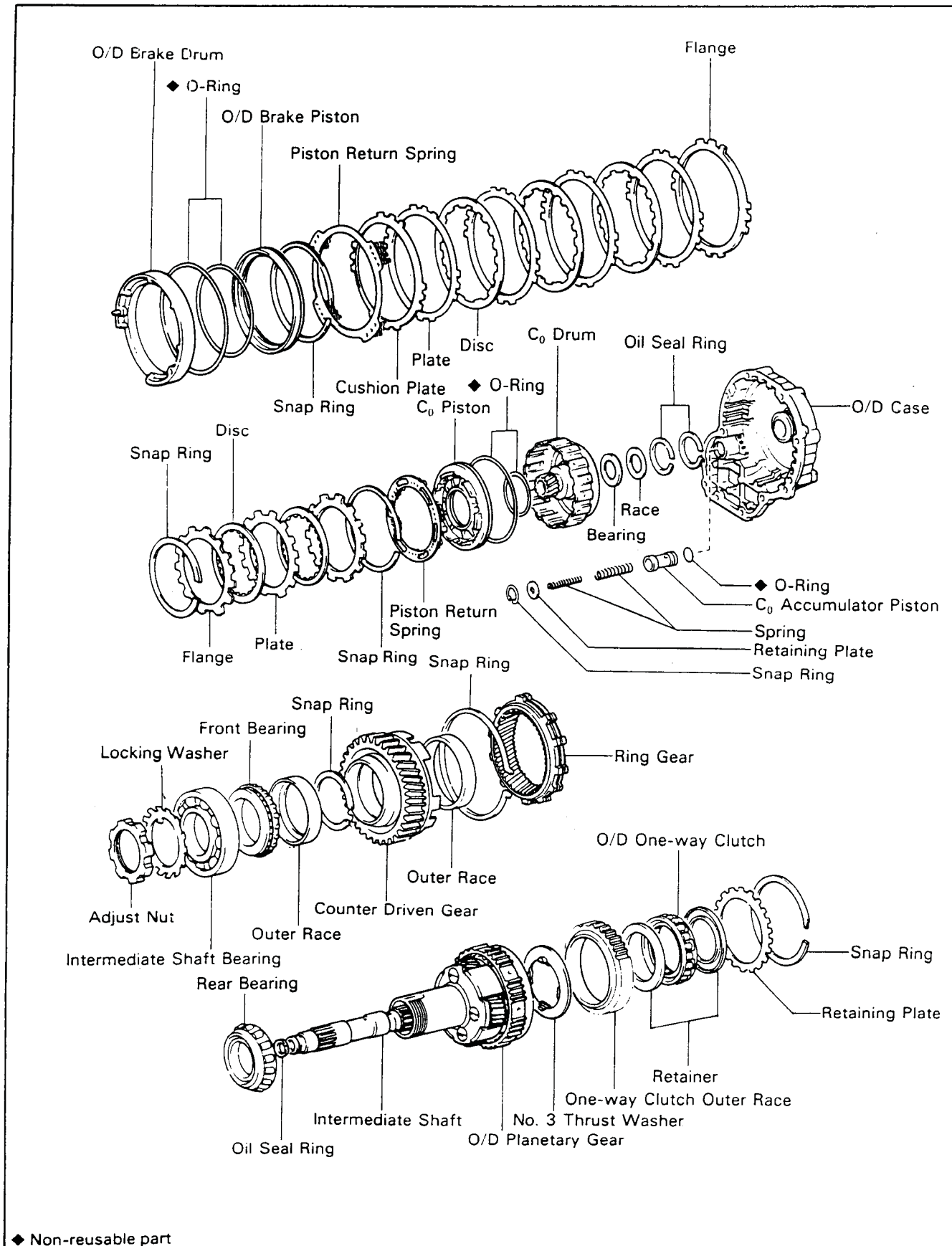



INSPECTION OF OVERDRIVE DIRECT CLUTCH

INSPECT OVERDRIVE DIRECT CLUTCH

Check that the check ball is free by shaking the piston.

Check that the valve does not leak by applying low-pressure compressed air.

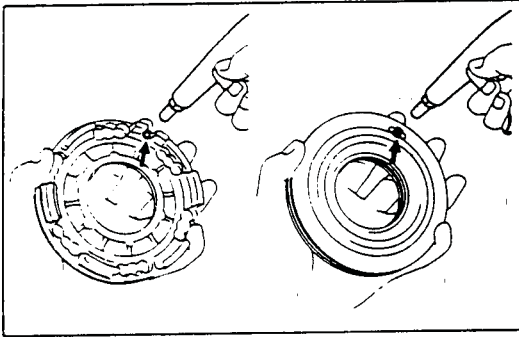

CHECK DIRECT CLUTCH BUSHING

Using a dial indicator, measure the inside diameter of the two direct clutch bushings.

Maximum inside diameter: 22.13 mm (0.8713 in.)

If the inside diameter is greater than the maximum, replace the direct clutch drum.

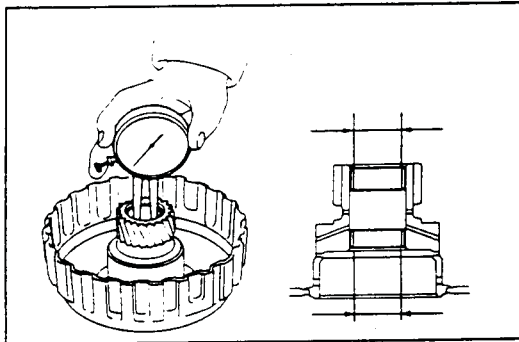

ASSEMBLY OF OVERDRIVE DIRECT CLUTCH

INSTALL CLUTCH PISTON

Install new O-rings to the piston. Coat the O-rings with ATF.

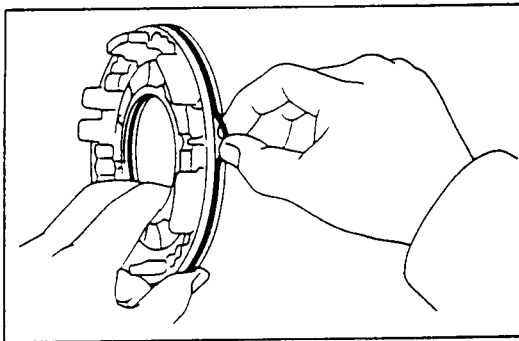

Press the piston into the drum with the cup side up, being careful not to damage the O-ring.

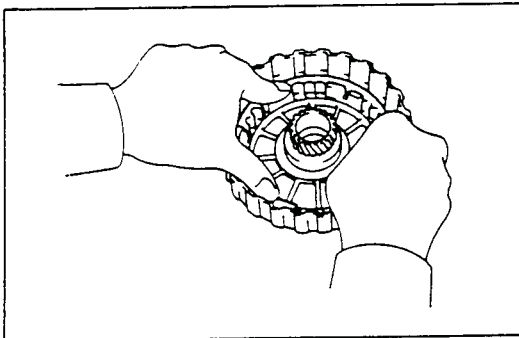

INSTALL PISTON RETURN SPRING

(a) Install the return spring and set snap ring in place.

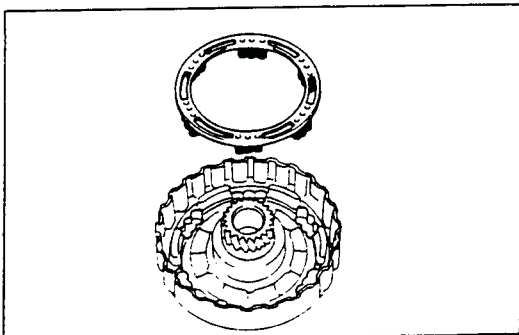



Technical Service Information

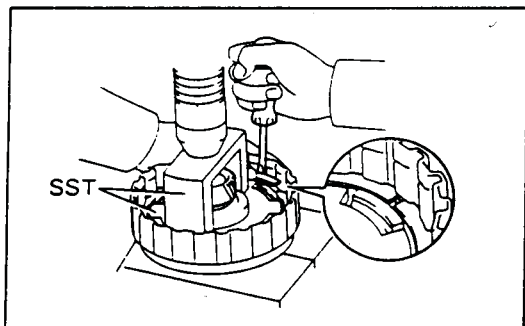

Place SST on the spring retainer, and compress the spring with a shop press.

SST 09350-32014 (09351-32070, 09351-32200)

Install the snap ring with a screwdriver. Be sure end gap of snap ring is aligned with the groove of the clutch drum.

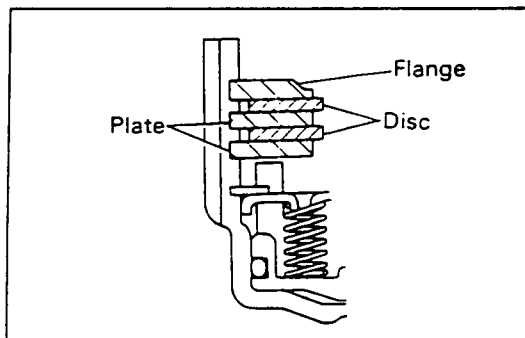

INSTALL PLATES, DISCS AND FLANGE

Install in order: P=Plate D=Disc

P-D-P-D-Flange

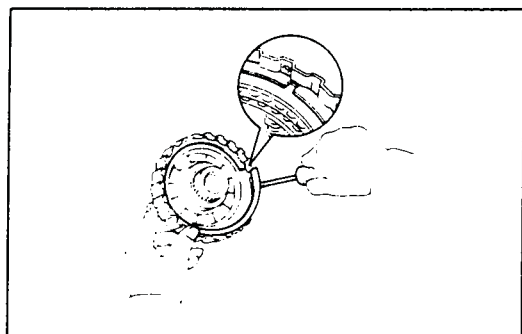

INSTALL SNAP RING

Be sure end gap of the snap ring is not aligned with the groove of the clutch drum.

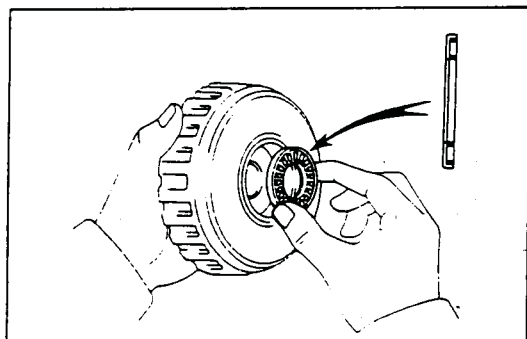

INSTALL BEARING AND RACE

Coat the bearing with petroleum jelly and install it facing the race side downward to the clutch drum.

Bearing: Outer diameter 46.3 mm (1.823 in.)

Inner diameter 26.2 mm (1.031 in.)

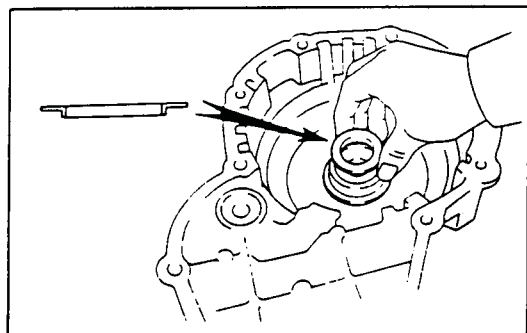

Coat the race with petroleum jelly and install it to the case.

Race: Outer diameter 43.0 mm (1.693 in.)

Inner diameter 24.5 mm (0.965 in.)



Technical Service Information

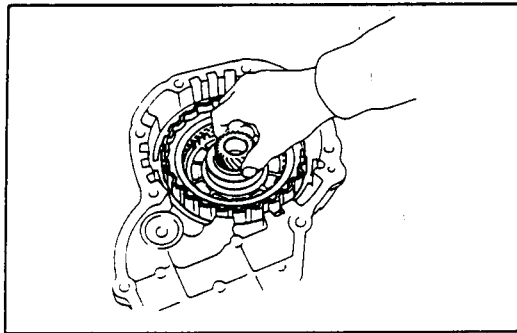

INSTALL DIRECT CLUTCH ON CASE

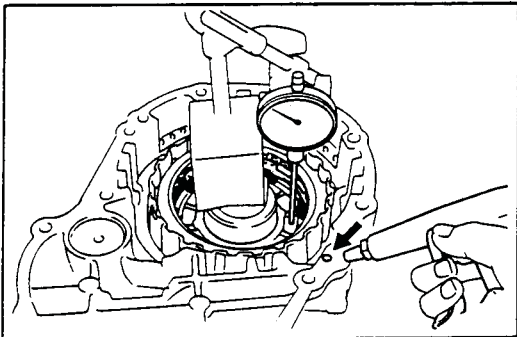

RECHECK PISTON STROKE OF DIRECT CLUTCH

Using a dial indicator, measure the piston stroke while applying and releasing the compressed air (4 – 8 kg/cm², 57 – 114 psi or 392 – 785 kPa) as shown.

Piston stroke: 1.75 – 2.49 mm
(0.0689 – 0.0980 in.)

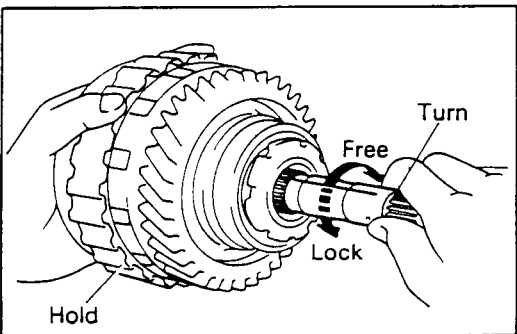

DISASSEMBLY OF COUNTER DRIVE GEAR

CHECK OPERATION OF ONE-WAY CLUTCH

Install the overdrive direct clutch into the one-way clutch.

Hold the overdrive direct clutch and turn the intermediate shaft. The shaft should turn freely clockwise and should lock counterclockwise.

Remove the overdrive direct clutch.

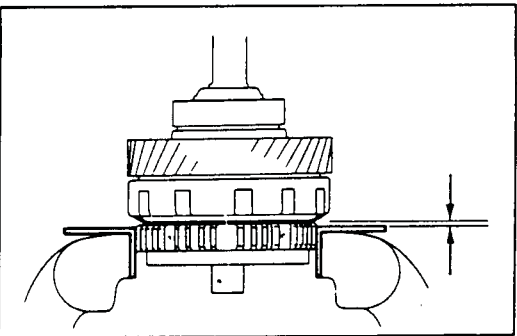

CHECK COUNTER DRIVE GEAR PRELOAD

Hold the overdrive planetary gear in a vise with soft jaws.

NOTE: Do not let the counter drive gear touch the vise.

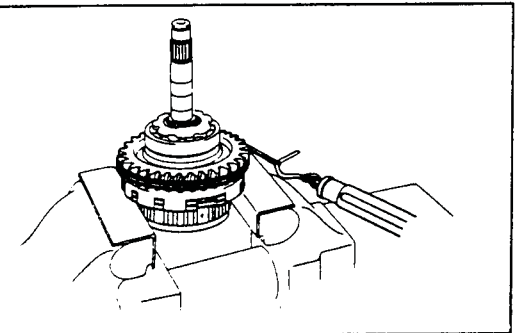

Using a tension gauge, measure the preload.

Preload (at starting): 940 – 1,560 g
(2.1 – 3.4 lb, 9.2 – 15.3 N)

NOTE: Turn the counter drive gear right and left several times before measuring the preload.



Technical Service Information

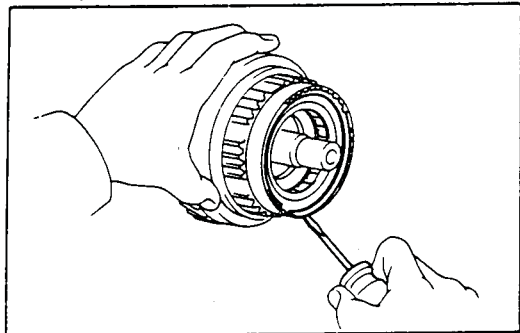

REMOVE ONE-WAY CLUTCH AND OUTER RACE

Remove the snap ring.

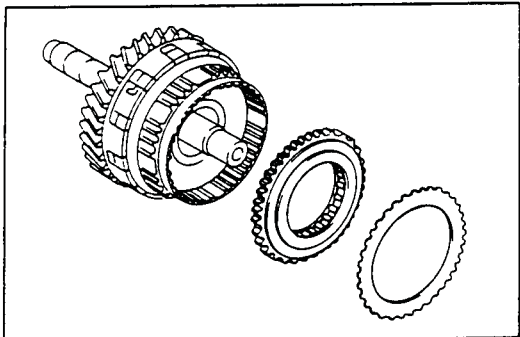

Remove the retaining plate.

Remove the one-way clutch with outer race.

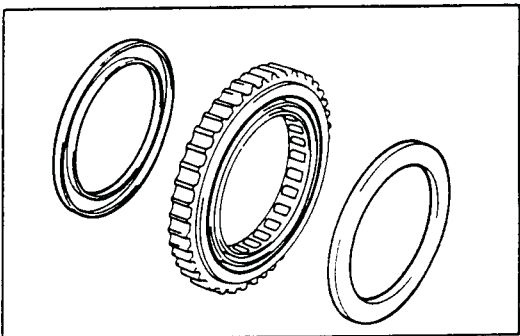

Remove the two retainers from both sides of the one-way clutch.

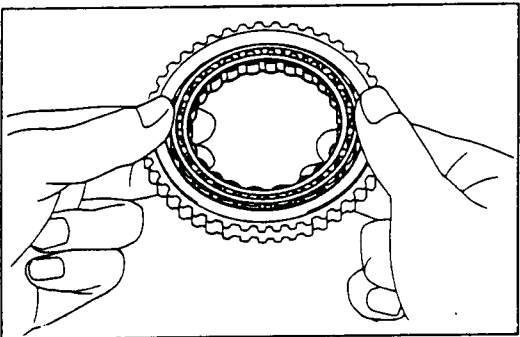

Remove the one-way clutch from the outer race.

NOTE: Note the direction of the one-way clutch.

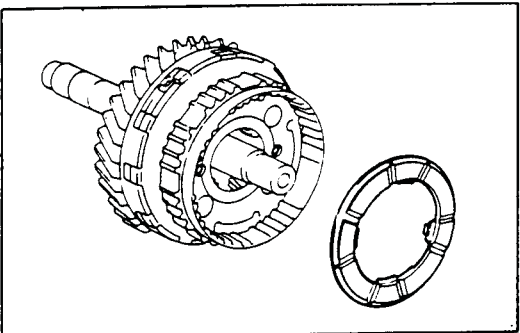

REMOVE NO. 3 PLANETARY THRUST WASHER



Technical Service Information

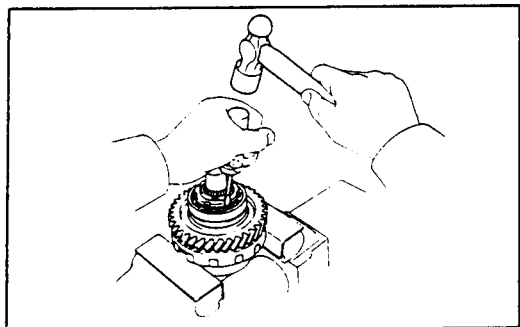

REMOVE ADJUSTING NUT AND LOCKING WASHER

Pry off the locking washer.

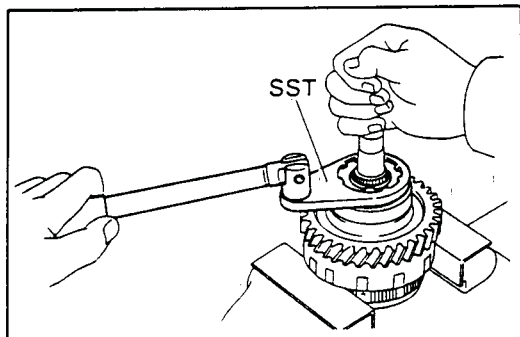

Using SST, loosen the adjusting nut.

SST 09350-32014 (09351-32080)

Remove the adjusting nut and locking washer.

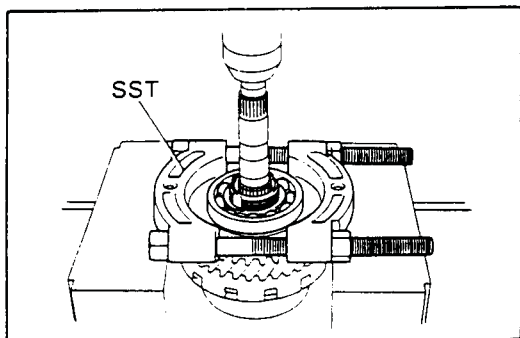

REMOVE INTERMEDIATE SHAFT BEARING

Using SST, press out the bearing from the shaft.

SST 09950-00020

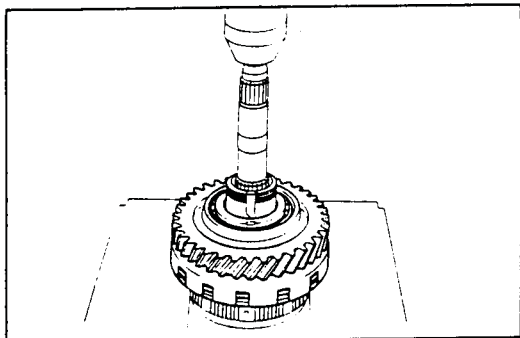

REMOVE COUNTER DRIVE GEAR AND FRONT BEARING

Press out the gear and bearing together.

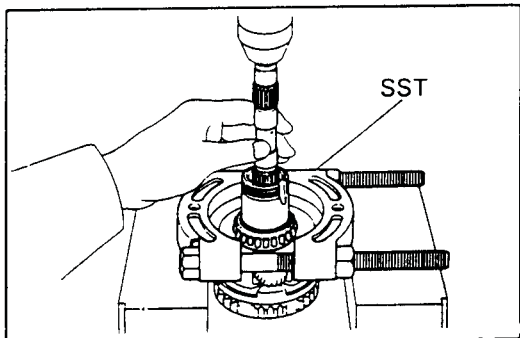

REMOVE REAR BEARING

Using SST, press out the bearing.

SST 09950-00020

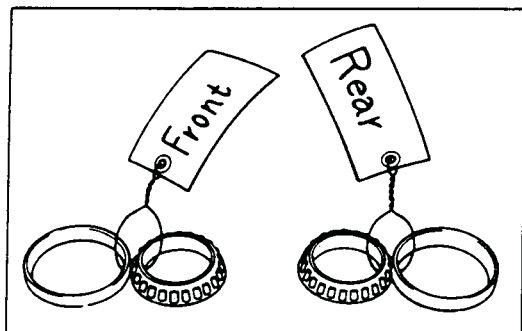

Tag the bearings to show the location for reassembly.

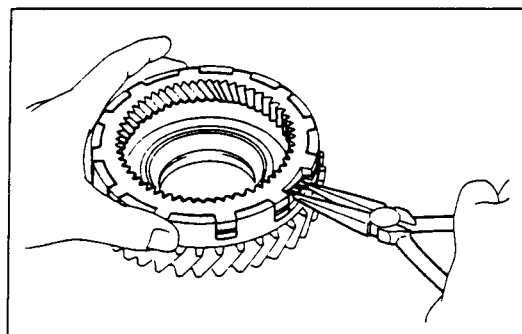

REMOVE OVERDRIVE PLANETARY RING GEAR FROM COUNTER DRIVE GEAR

While pulling up the ring gear, compress the snap ring with needle-nose pliers and remove it from the groove.

Remove the ring gear from the counter drive gear.

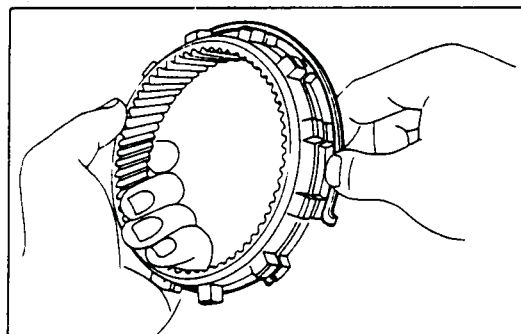

Remove the snap ring from the ring gear.

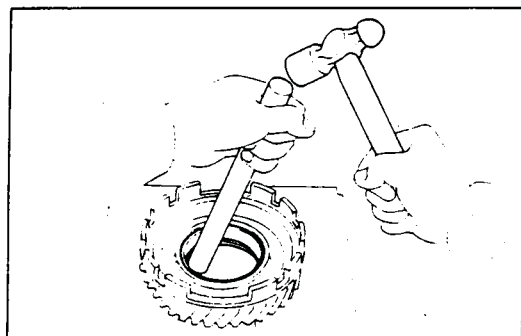

REMOVE OUTER RACES FROM COUNTER DRIVE GEAR

Drive out the two races with a brass bar and hammer.

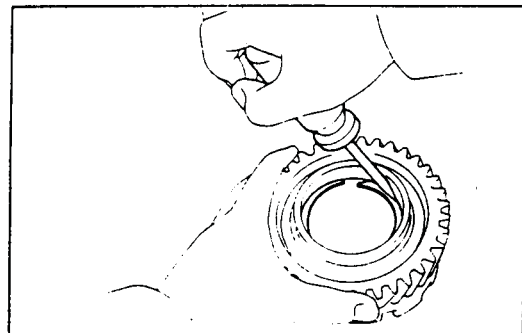

REMOVE SNAP RING FROM COUNTER DRIVE GEAR

Using a screwdriver, remove the snap ring.

ASSEMBLY OF COUNTER DRIVE GEAR

INSTALL SNAP RING INTO COUNTER GEAR

Install the snap ring with a screwdriver.



Technical Service Information

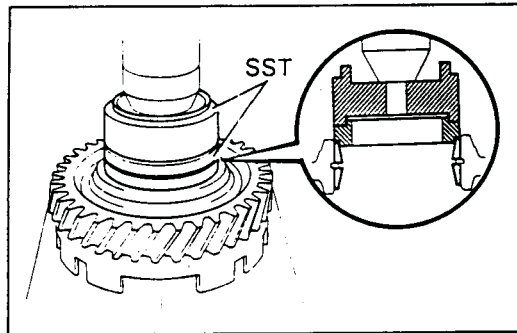

INSTALL OUTER RACES INTO COUNTER DRIVE GEAR

Using SST, press in the two outer races to the gear both side.

SST 09350-32014 (09351-32120, 09351-32150)

NOTE: Press in the two outer races until they touch the snap ring. Tap the races in straight, so that they do not tilt.

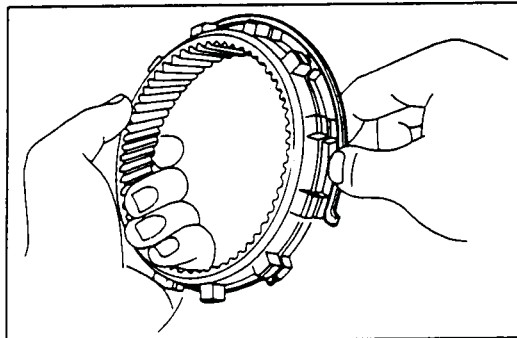

INSTALL OVERDRIVE PLANETARY RING GEAR INTO COUNTER DRIVE GEAR

Install the snap ring to the ring gear.

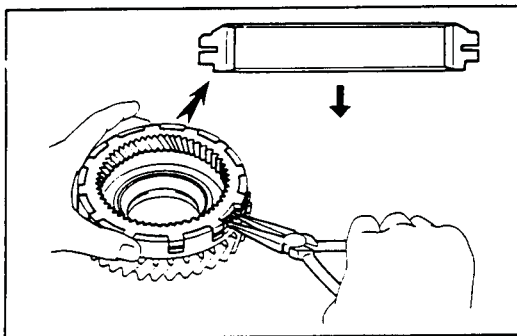

While pushing down the ring gear, squeeze the snap ring end with a needle-nose pliers, and install it into the groove.

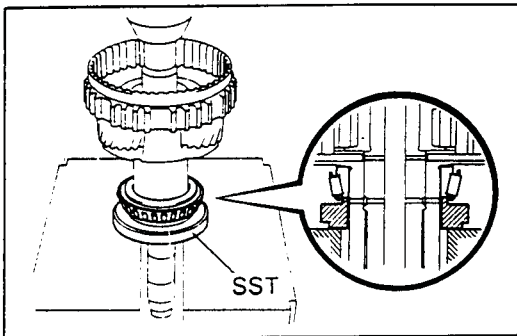

INSTALL REAR BEARING

Using SST, press in the bearing onto the shaft.

SST 09350-32014 (09351-32120)

NOTE: Press in the bearing until the side surface of the inner race touches the planetary carrier.

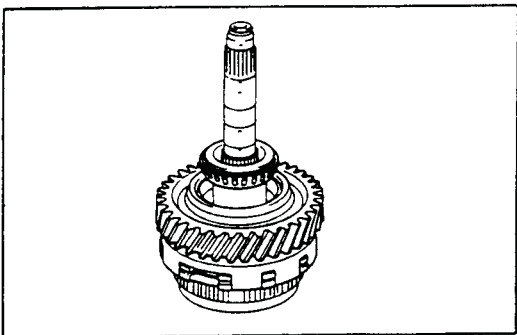

INSTALL COUNTER DRIVE GEAR AND FRONT BEARING

Install the gear onto the shaft, and mesh the ring gear with the planetary pinions.

Place the front bearing onto the shaft.



Technical Service Information

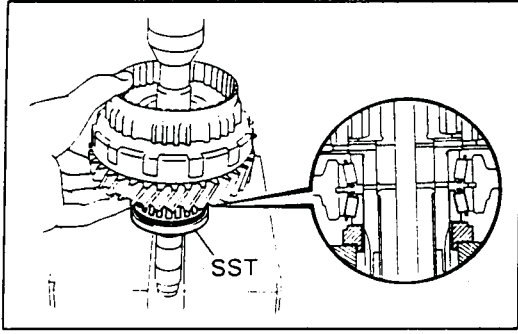

Using SST, press in the bearing until slightly play between the bearings.

SST 09350-32014 (09351-32120)

NOTE: Hold the ring gear to prevent it from falling.

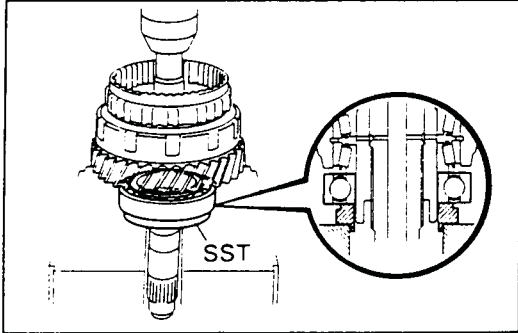

INSTALL INTERMEDIATE SHAFT BEARING

Using SST, press in the bearing until it slightly touches the front bearing of the counter drive gear.

SST 09350-32014 (09351-32120)

NOTE: The counter drive gear can be turned lightly.

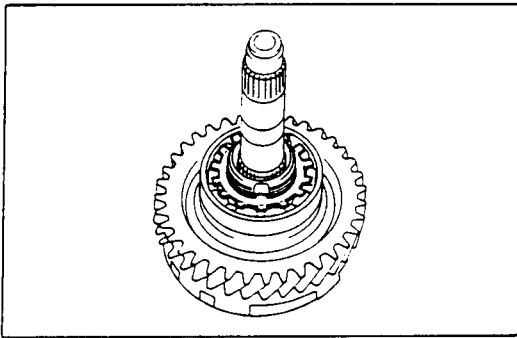

PLACE NEW LOCKING WASHER

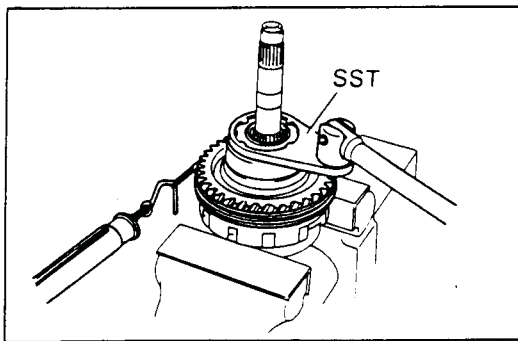

INSTALL ADJUSTING NUT AND ADJUST PRELOAD OF COUNTER DRIVE GEAR

Hold the overdrive planetary gear in a vise with soft jaws.

Using SST, tighten the adjusting nut until the following gear starting load occurs with a tension gauge.

SST 09350-32014 (09351-32080)

Preload (at starting): **940 – 1,560 g**
(2.1 – 3.4 lb, 9.2 – 15.3 N)

NOTE: Turn the counter drive gear right and left several times before measuring the preload.

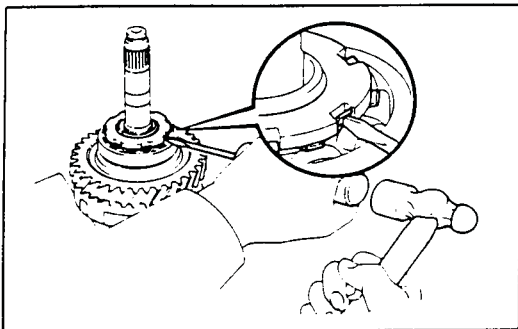

Lock the adjusting nut with one tab on locking washer. Bend the locking washer tab until it is even with the adjusting nut groove.



Technical Service Information

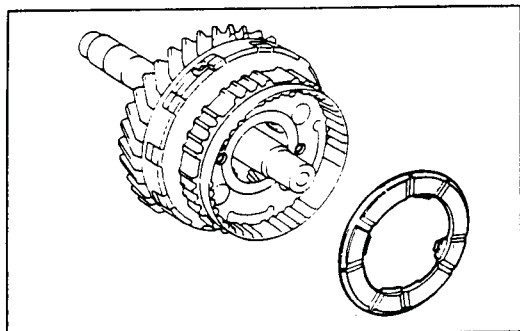

INSTALL NO. 3 OVERDRIVE PLANETARY THRUST WASHER

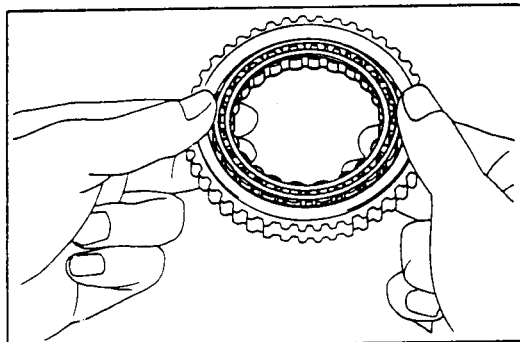

INSTALL OVERDRIVE ONE-WAY CLUTCH AND RETAINING PLATE

Install the one-way clutch into the outer race.

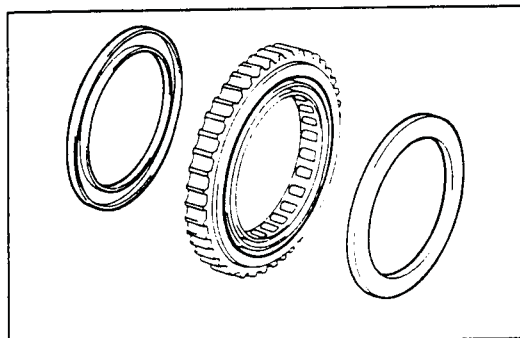

Install the two retainers on both sides of the one-way clutch.

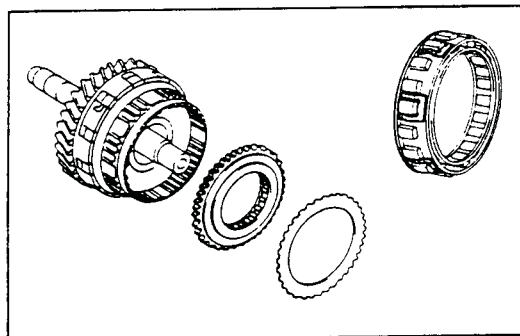

Install the one-way clutch into the overdrive planetary gear.

NOTE: Be sure that the one-way clutch is installed in correct direction.

Install the retaining plate.

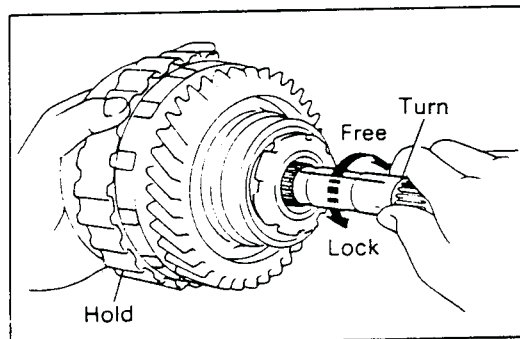

CHECK OPERATION OF ONE-WAY CLUTCH

Install the overdrive direct clutch into the one-way clutch.

Hold the overdrive direct clutch and turn the intermediate shaft. The shaft should turn freely clockwise and should lock counterclockwise.

Remove the overdrive direct clutch.

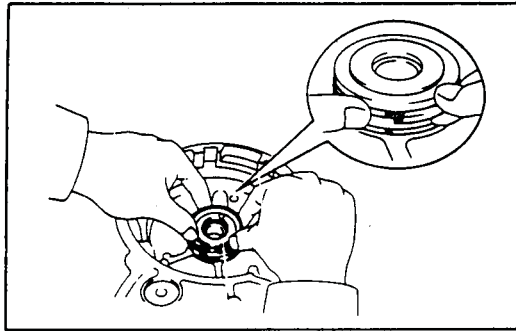

ASSEMBLY OF OVERDRIVE CASE

INSTALL OIL SEAL RINGS ON OVERDRIVE CASE

Spread the two rings apart and install them into the groove.

NOTE: After installing the oil seal rings, check that they move smoothly.

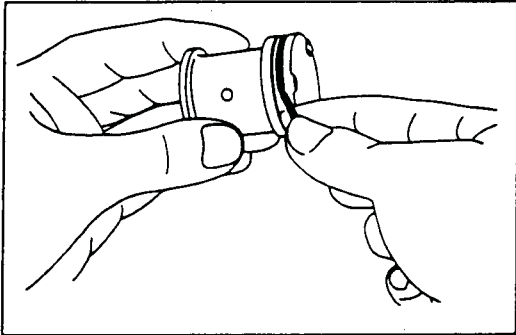

INSTALL C₀ ACCUMULATOR PISTON TO OVERDRIVE CASE

Install a new O-ring to the accumulator piston.

Coat the O-ring with ATF.

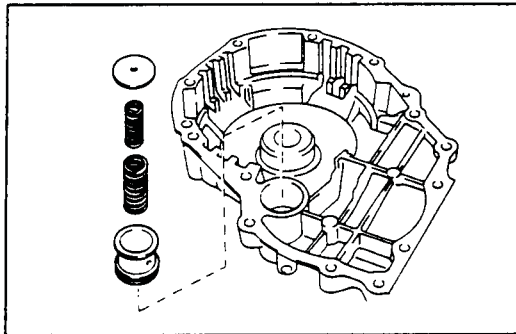

Install the accumulator piston, two springs and retaining plate.

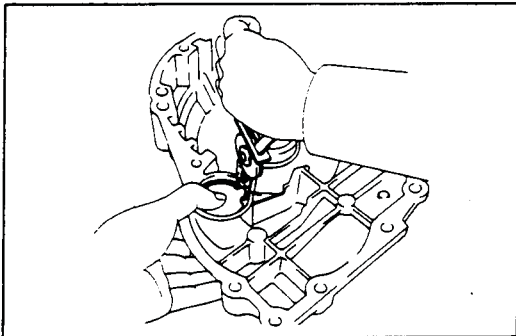

Using snap ring pliers, install the snap ring.

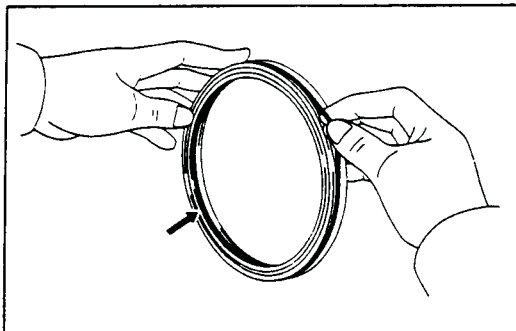

ASSEMBLY OF OVERDRIVE BRAKE

INSTALL PISTON INTO DRUM

Install the new O-rings to the piston.

Coat the O-rings with ATF.



Technical Service Information

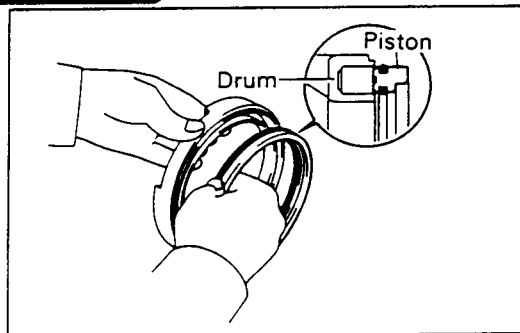

Press the piston into the drum, being careful not to damage the O-rings.

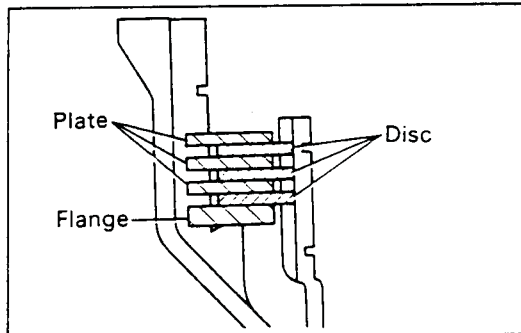

INSTALL FLANGE, DISCS AND PLATES

Install the flange, discs and plates.

Install in order: P=Plate D=Disc
Flange-D-P-D-P-D-P

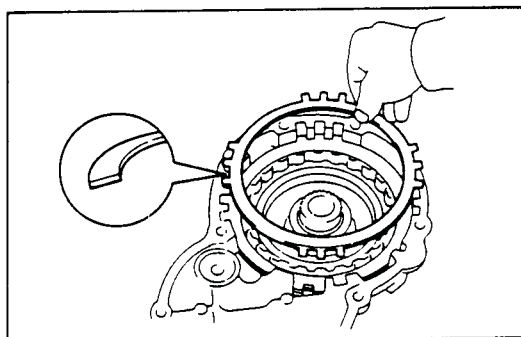

Install the cushion plate facing the rounded end upward.

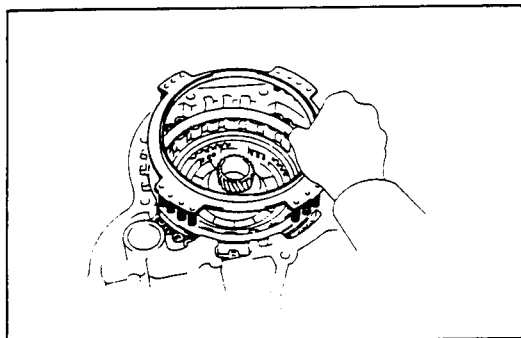

POSITION PISTON RETURN SPRING

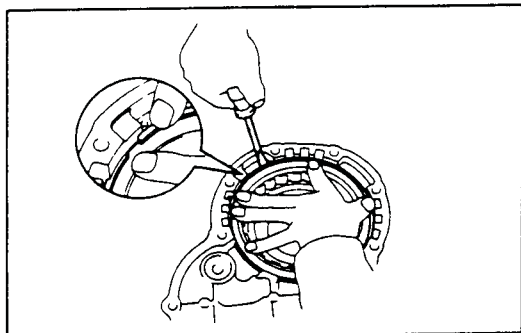

INSTALL SNAP RING INTO CASE

Be sure the end gap of the snap ring is not aligned with one of cutouts.



Technical Service Information

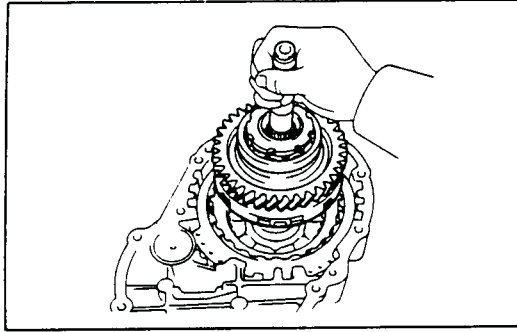

INSTALL OVERDRIVE PLANETARY GEAR ONTO OVERDRIVE DIRECT CLUTCH

While turning the overdrive planetary gear clockwise, install it onto the overdrive direct clutch.

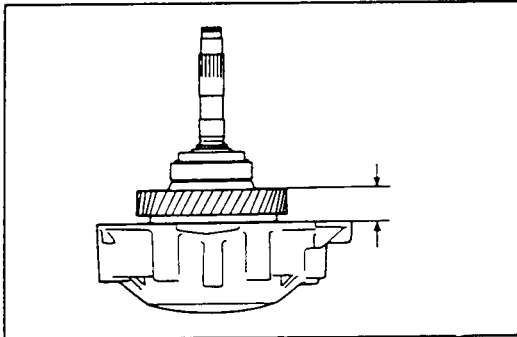

NOTE: If the overdrive planetary gear is properly installed onto the direct clutch, the counter drive gear height from the overdrive case will be about 24 mm (0.94 in.).

Valve Body COMPONENTS

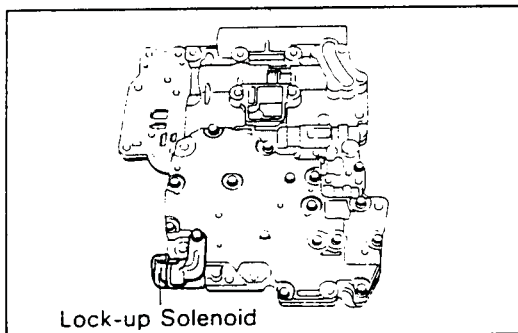
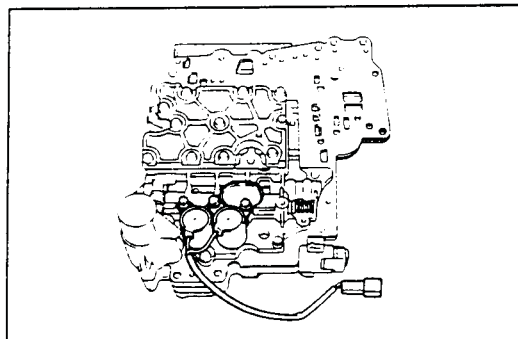
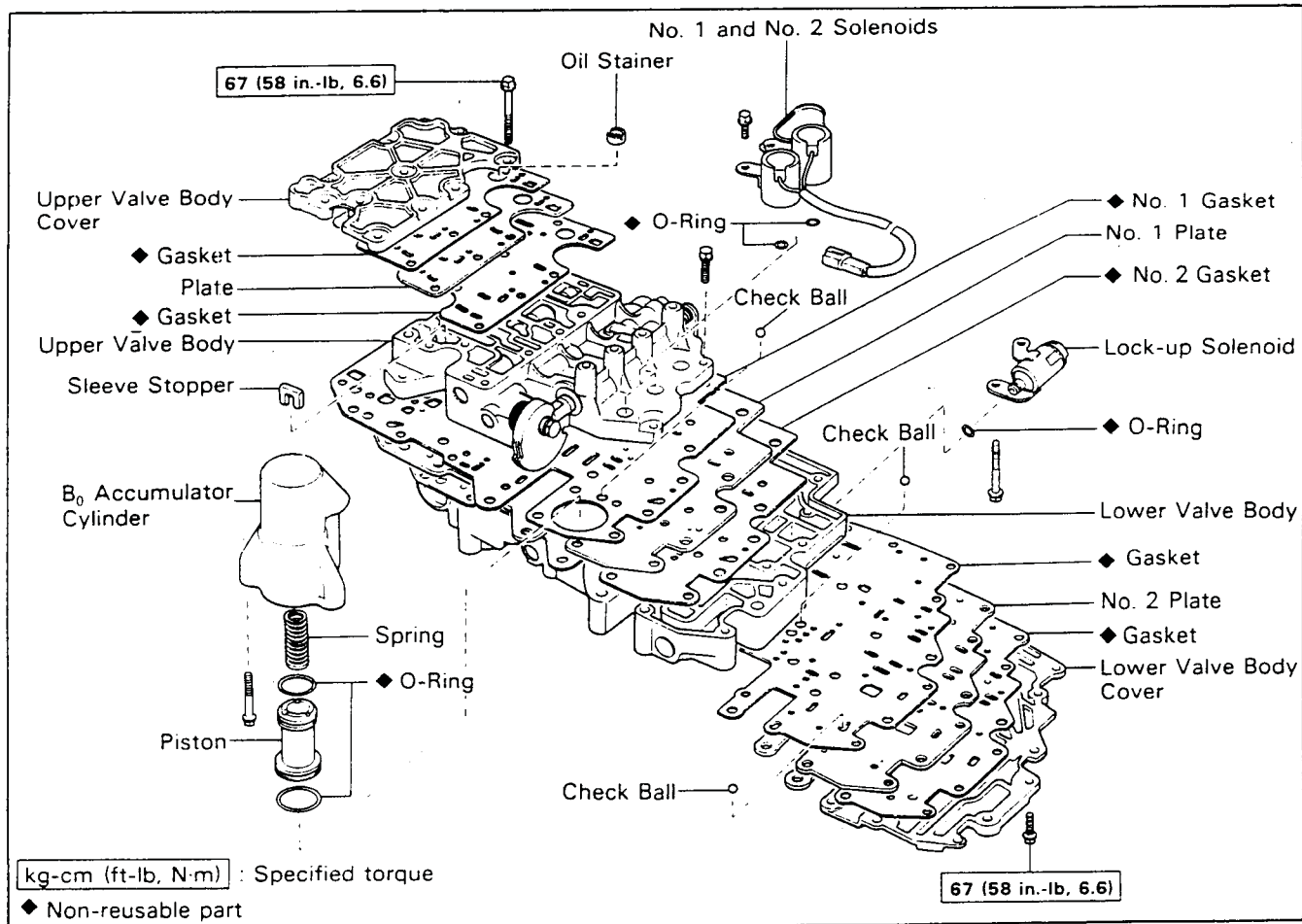

(Disassembly of Valve Body)

CAUTION: When disassembling the valve body, be careful not to damage or deform the plate which overhang the valve body.

REMOVE SOLENOIDS

Remove No. 1 and No. 2 solenoids.

CAUTION: When removing the solenoid, do not use a screwdriver, etc. to pry up the solenoid.

Remove the O-ring from each solenoid.

Remove the lock-up solenoid.

Remove the O-ring from the solenoid.



Technical Service Information

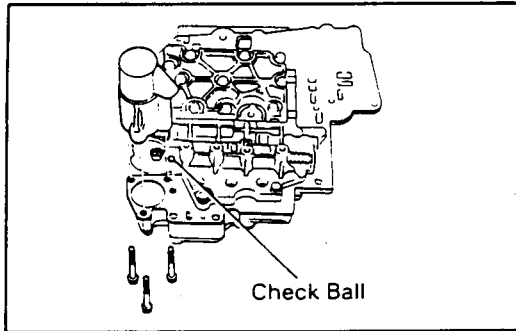

REMOVE B₀ ACCUMULATOR ASSEMBLY

Remove the three bolts.

Remove the B₀ accumulator assembly.

Remove the check ball on No. 1 plate.

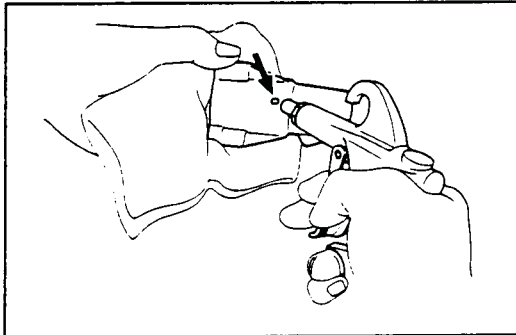

DISASSEMBLE B₀ ACCUMULATOR ASSEMBLY

Applying compressed air to the cylinder hole, remove the piston and spring.

Remove the two O-rings from the piston.

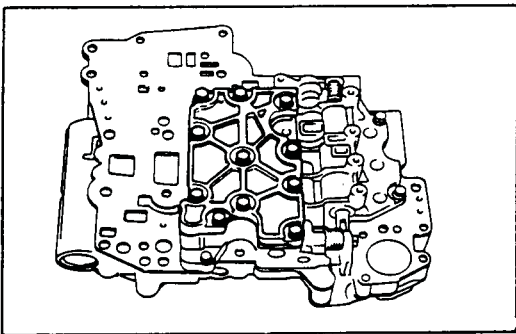

REMOVE UPPER VALVE BODY COVER

Remove the eleven bolts and upper valve body cover.

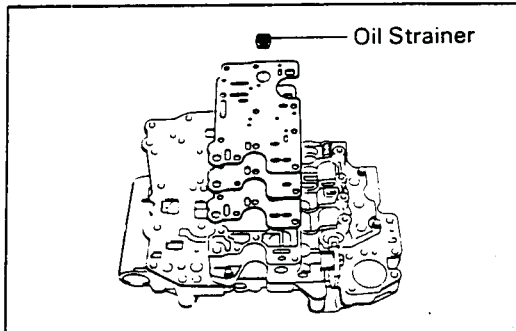

REMOVE THROTTLE MODULATOR OIL STRAINER, UPPER VALVE BODY COVER GASKETS AND PLATE

Remove the oil strainer on the gasket.

Remove the two gaskets and plate from the upper valve body.

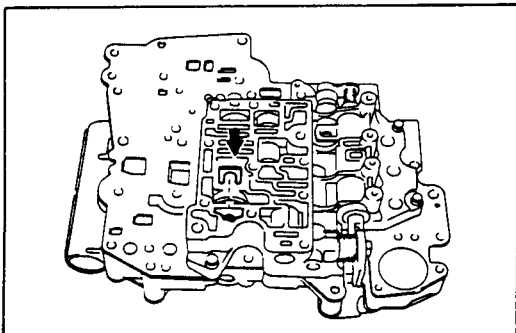

REMOVE LOCK-UP RELAY VALVE SLEEVE STOPPER



Technical Service Information

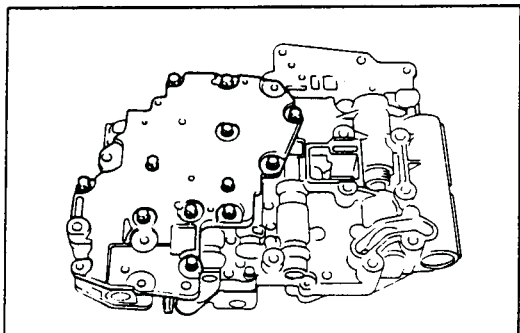

REMOVE LOWER VALVE BODY COVER

Remove the twelve bolts and lower valve body cover.

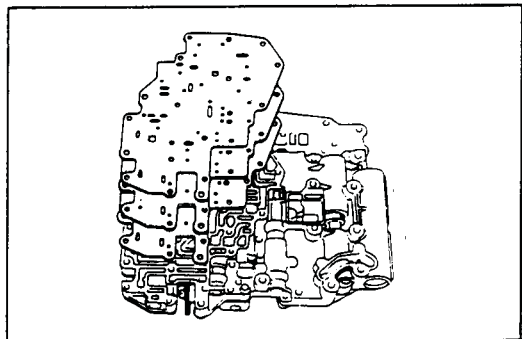

REMOVE LOWER VALVE BODY COVER GASKETS AND NO. 2 PLATE

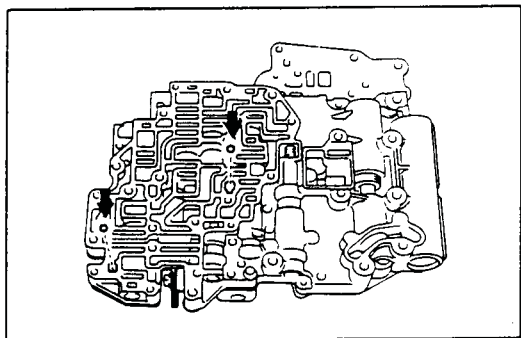

REMOVE CHECK BALLS

Remove the two check balls from the lower valve body.

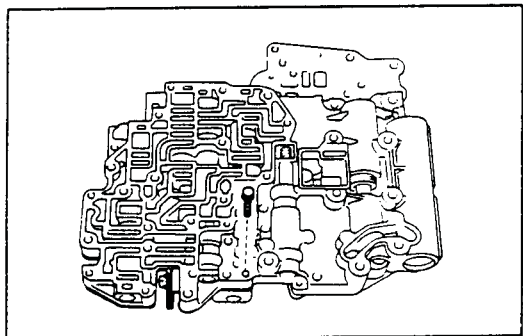

REMOVE BOLT FROM LOWER VALVE BODY

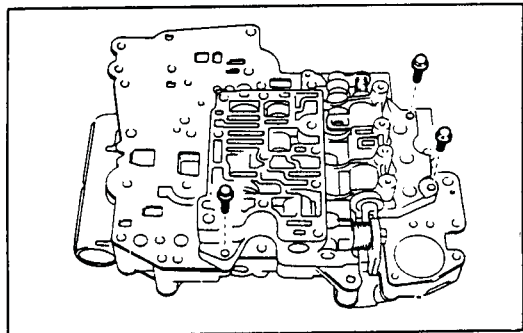

REMOVE BOLTS FROM UPPER VALVE BODY

Remove the three bolts.

Technical Service Information

(Upper Valve Body)

COMPONENTS

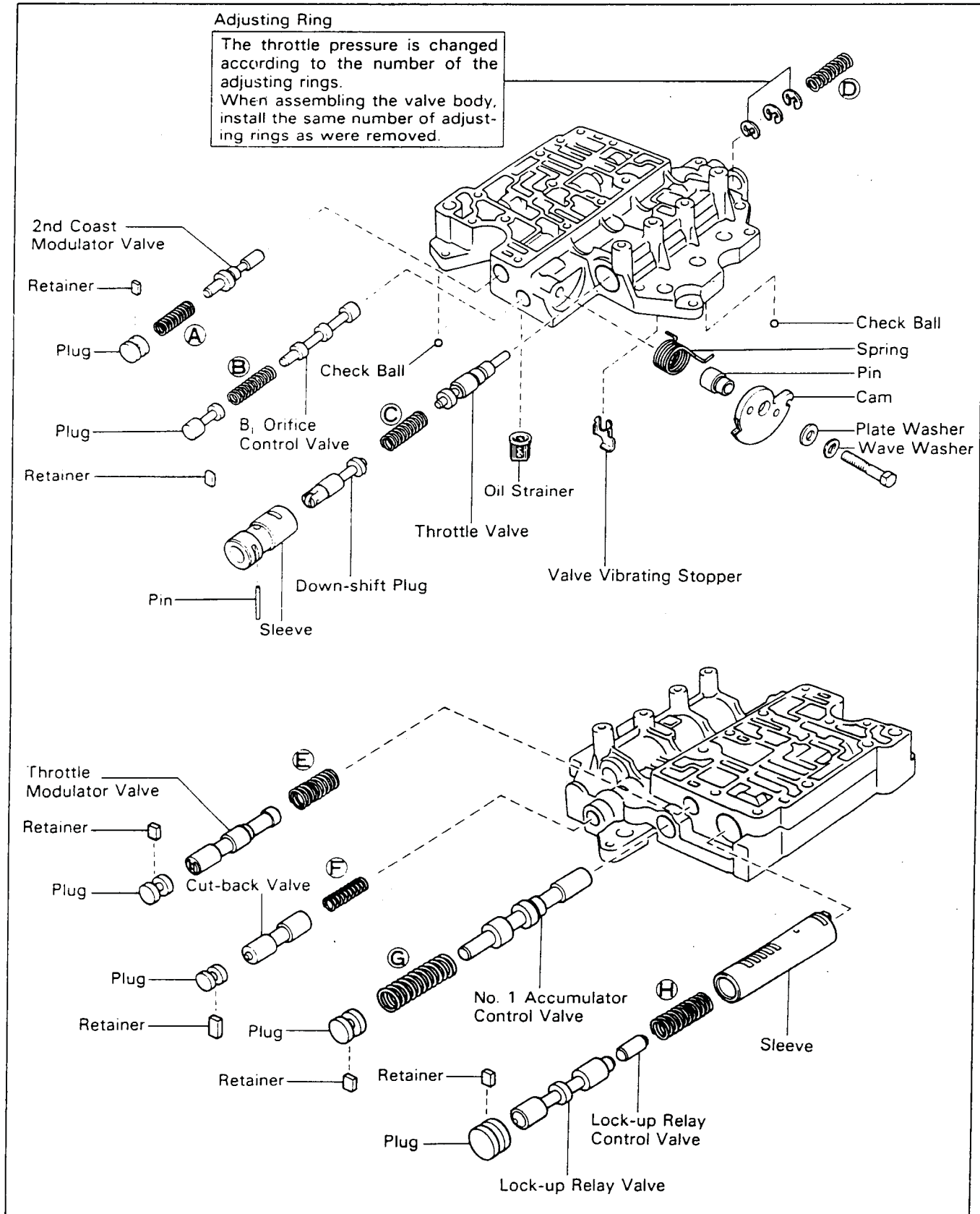



Technical Service Information

SPECIFICATIONS OF VALVE BODY SPRINGS

Spring	Free length mm (in.)	Coil outer diameter mm (in.)	Total No. of coils	Color
A Second coast modulator valve	27.5 (1.083)	8.9 (0.350)	14.6	Brown
B B ₁ orifice control valve	24.8 (0.976)	8.0 (0.315)	12.0	White
C Down-shift plug	29.8 (1.173)	8.7 (0.343)	13.5	Yellow
D Throttle valve	30.7 (1.209)	9.2 (0.362)	9.5	Purple
E Throttle modulator valve	21.7 (0.854)	9.5 (0.374)	9.5	Orange
F Cut-back valve	21.8 (0.858)	6.0 (0.236)	13.5	Red
G No. 1 accumulator control valve	28.1 (1.106)	10.6 (0.417)	13.0	Yellow
H Lock-up relay valve	26.6 (1.047)	10.2 (0.402)	11.5	Green

NOTE: During reassembly please refer to the spring specifications above to help discrimination between the different springs.

SECTIONAL VIEW OF VALVE BODY

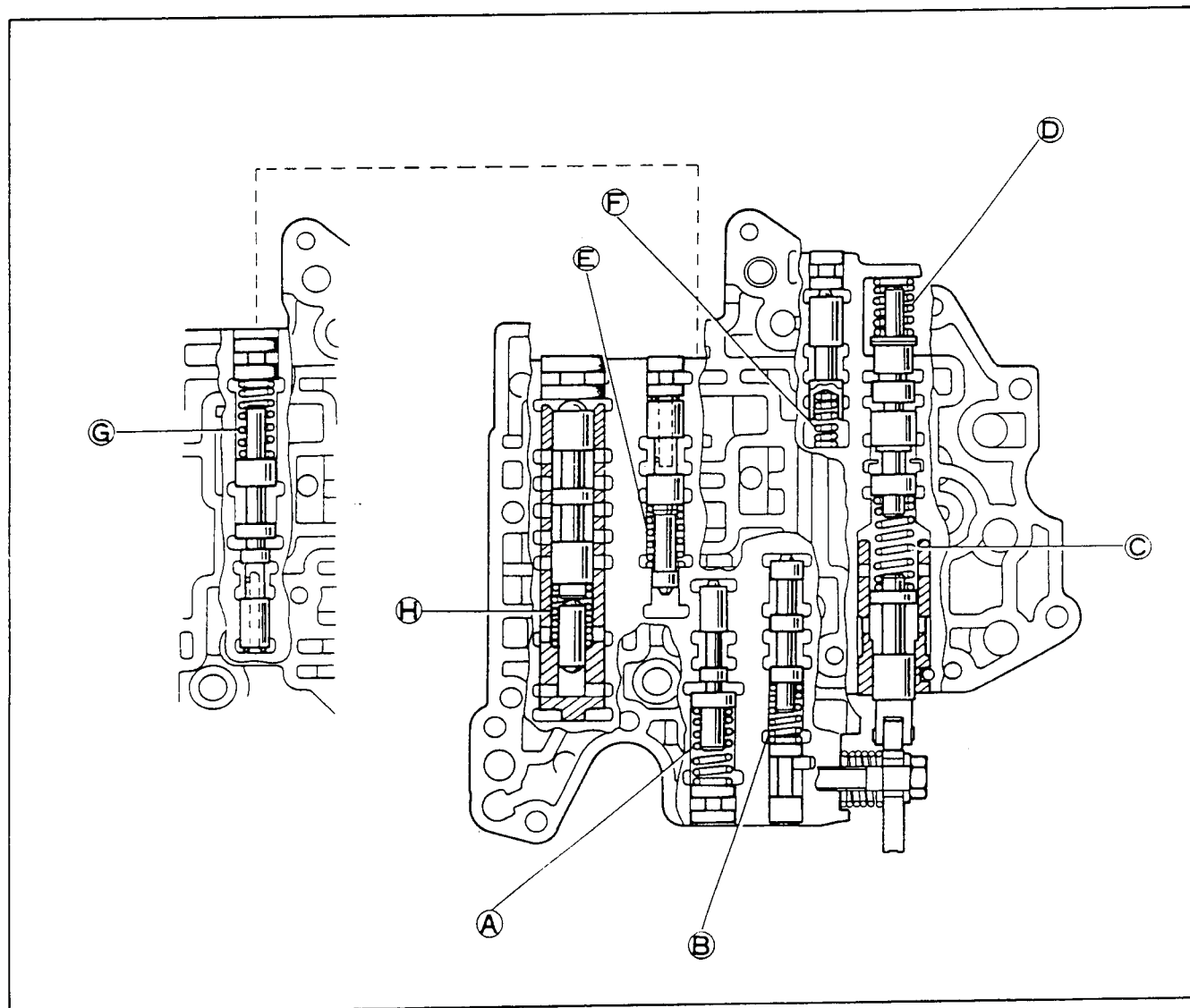

LOCATION OF RETAINERS, PIN, STOPPER, CHECK BALLS AND STRAINER

1. RETAINER, STOPPER AND PIN

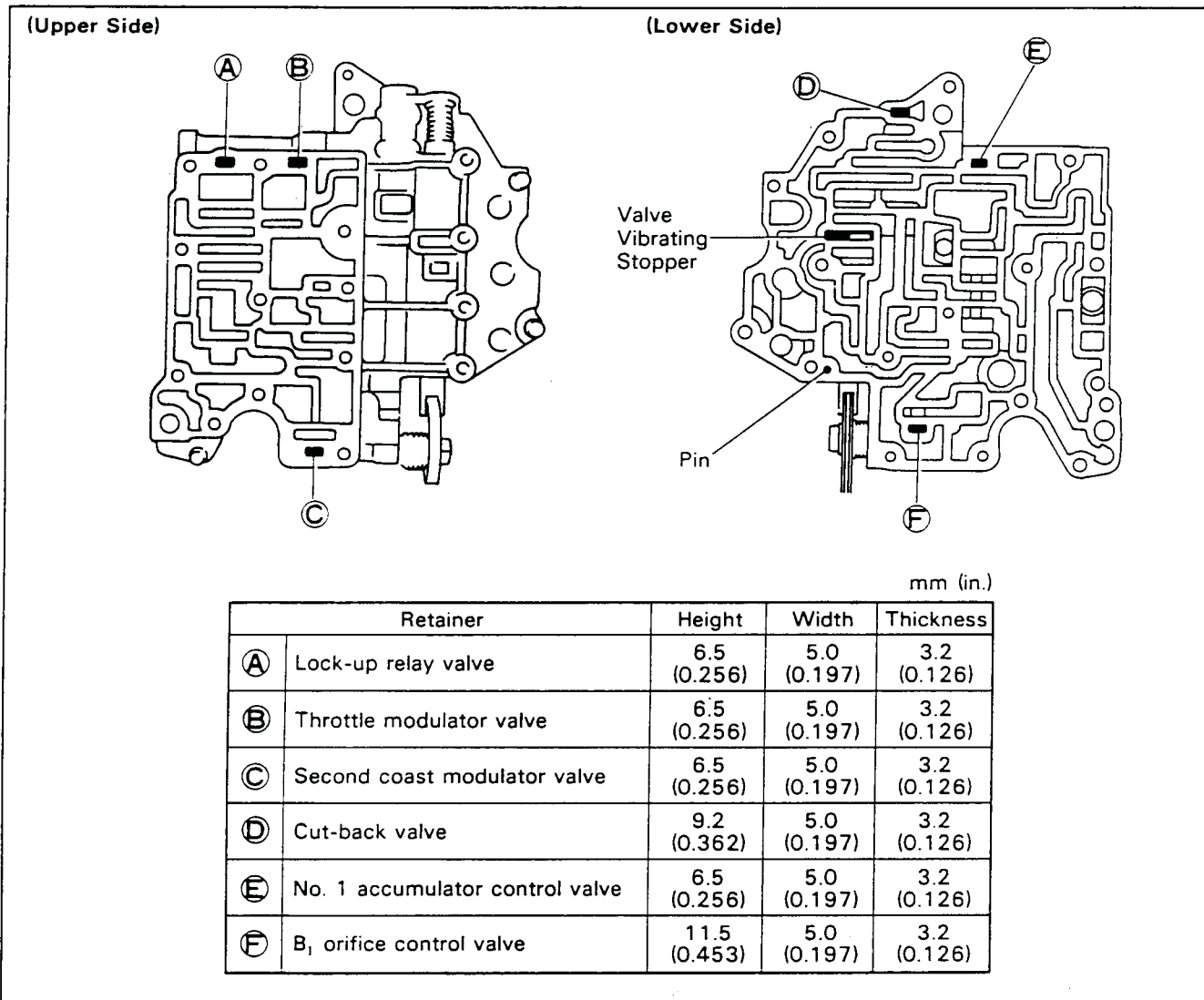

2. CHECK BALL

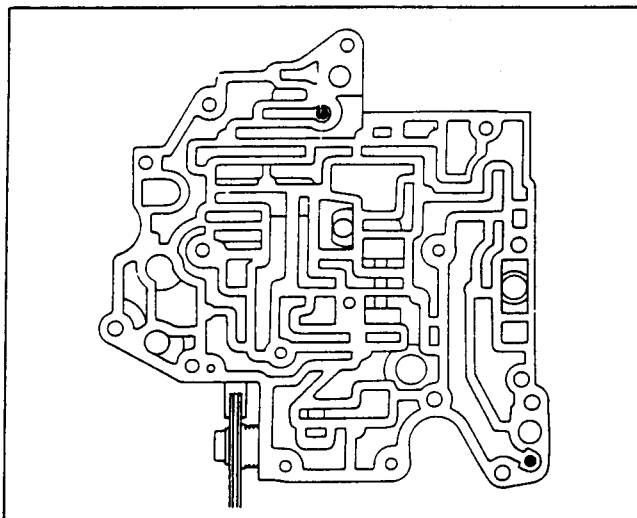

3. STRAINER

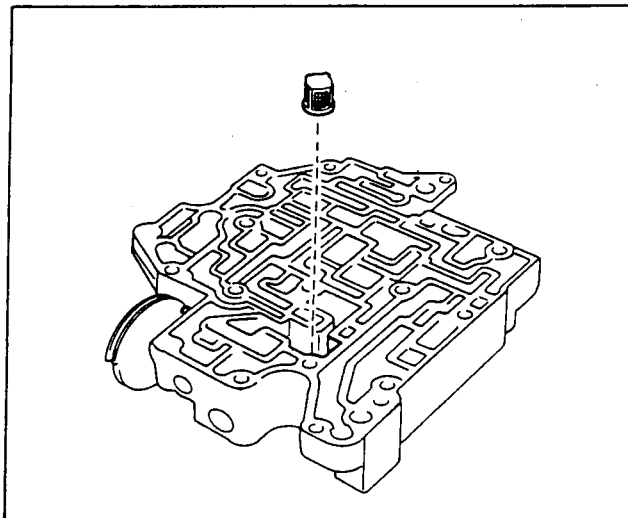

Technical Service Information (Lower Valve Body) COMPONENTS

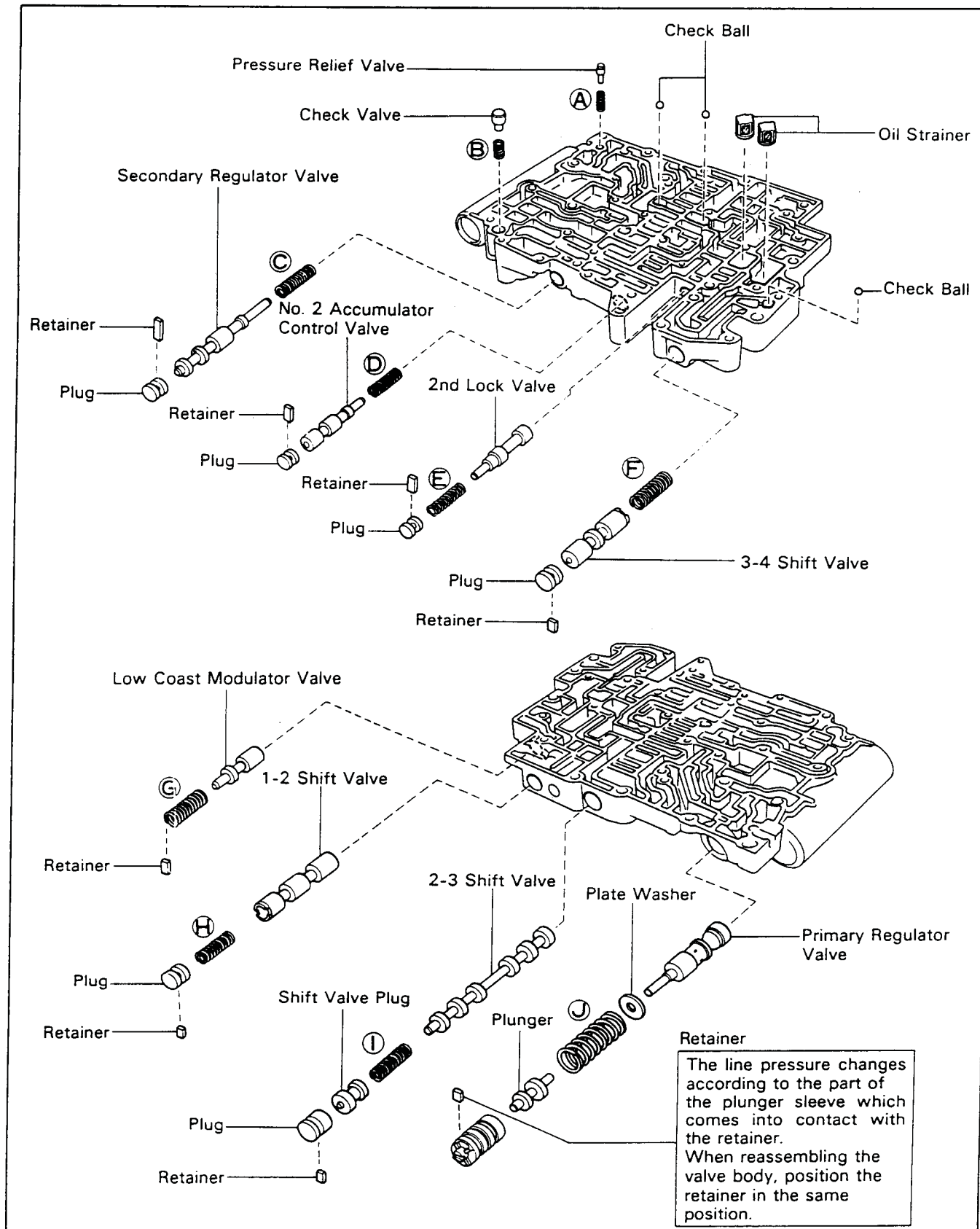

The line pressure changes according to the part of the plunger sleeve which comes into contact with the retainer. When reassembling the valve body, position the retainer in the same position.



Technical Service Information

SPECIFICATIONS OF VALVE BODY SPRINGS

Spring	Free length mm (in.)	Coil outer diameter mm (in.)	Total No. of coils	Color
(A) Pressure relief valve	11.2 (0.441)	6.4 (0.252)	7.5	None
(B) Check valve	19.9 (0.783)	11.0 (0.433)	8.5	None
(C) Secondary regulator valve	38.5 (1.516)	8.4 (0.331)	17.0	Purple
(D) No. 2 accumulator control valve	23.0 (0.906)	6.3 (0.248)	12.0	Gray
(E) Second lock valve	20.7 (0.815)	6.1 (0.240)	12.0	Orange
(F) 3-4 shift valve	29.2 (1.150)	8.9 (0.350)	12.0	Light Green
(G) Low coast modulator valve	20.2 (0.795)	7.9 (0.311)	11.9	Purple
(H) 1-2 shift valve	29.2 (1.150)	8.9 (0.350)	12.0	Light Green
(I) 2-3 shift valve	28.0 (1.102)	9.4 (0.370)	10.3	None
(J) Primary regulator valve	66.7 (2.626)	18.6 (0.732)	12.5	None

NOTE: During reassembly please refer to the spring specifications above to help discrimination between the different springs.

SECTIONAL VIEW OF VALVE BODY

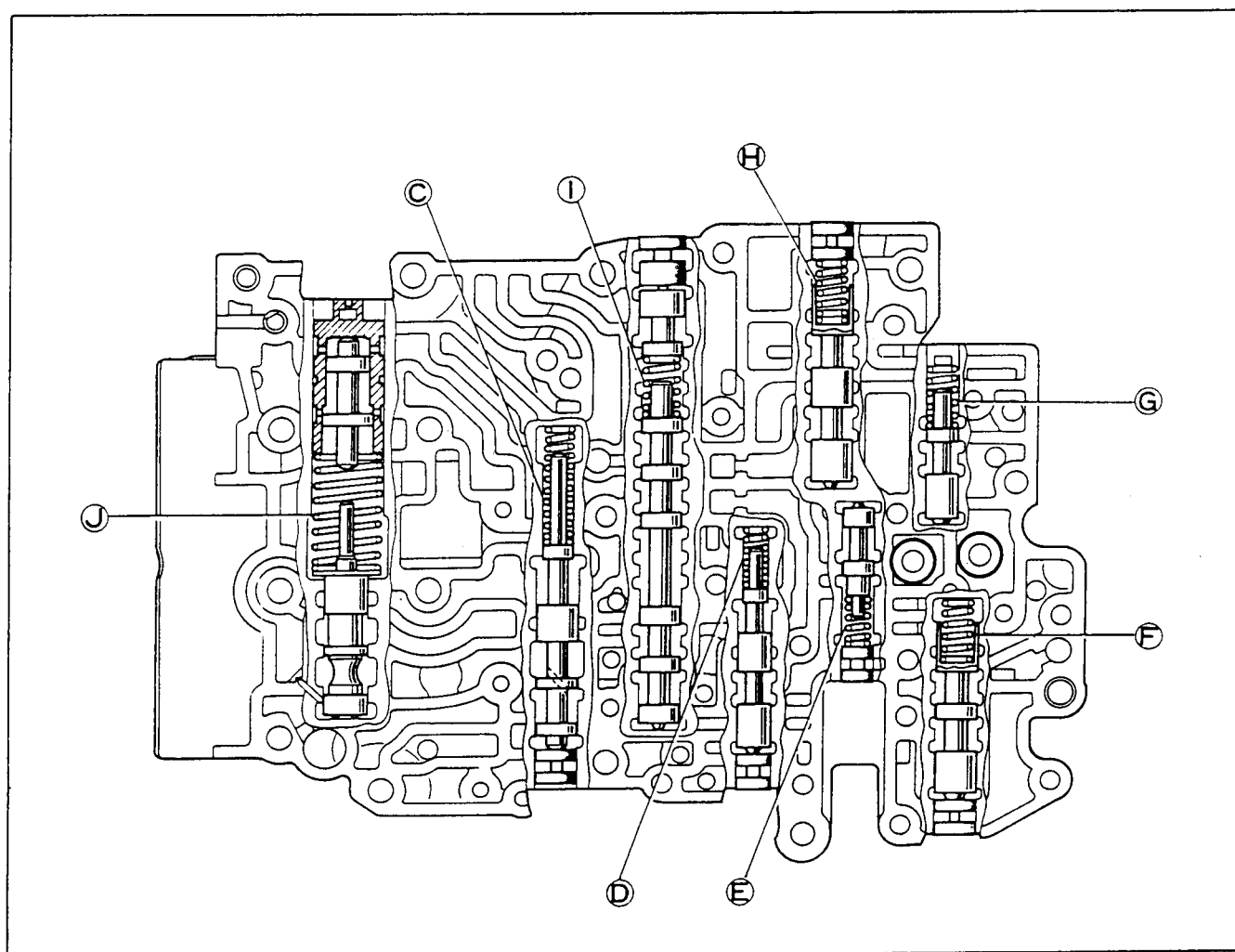



Technical Service Information

LOCATION OF RETAINERS, CHECK BALLS, STRAINERS, SPRINGS AND VALVES

RETAINER

(Upper Side) (Lower Side)

Retainer		Height	Width	Thickness
A	Primary regulator valve	9.2 (0.362)	5.0 (0.197)	3.2 (0.126)
B	Secondary regulator valve	15.0 (0.591)	5.0 (0.197)	3.2 (0.126)
C	No. 2 accumulator control valve	9.2 (0.362)	5.0 (0.197)	3.2 (0.126)
D	Second lock valve	11.5 (0.453)	5.0 (0.197)	3.2 (0.126)
E	Low coast modulator valve	11.5 (0.453)	5.0 (0.197)	3.2 (0.126)
F	1-2 shift valve	6.5 (0.256)	5.0 (0.197)	3.2 (0.126)
G	2-3 shift valve	9.2 (0.362)	5.0 (0.197)	3.2 (0.126)
H	3-4 shift valve	6.5 (0.256)	5.0 (0.197)	3.2 (0.126)

mm (in.)

CHECK BALL

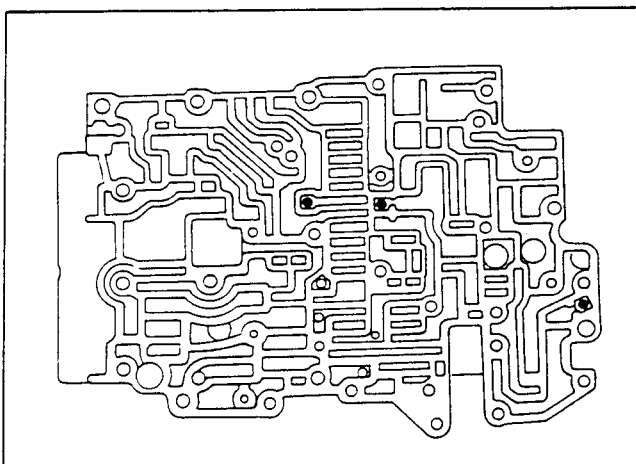

STRAINER

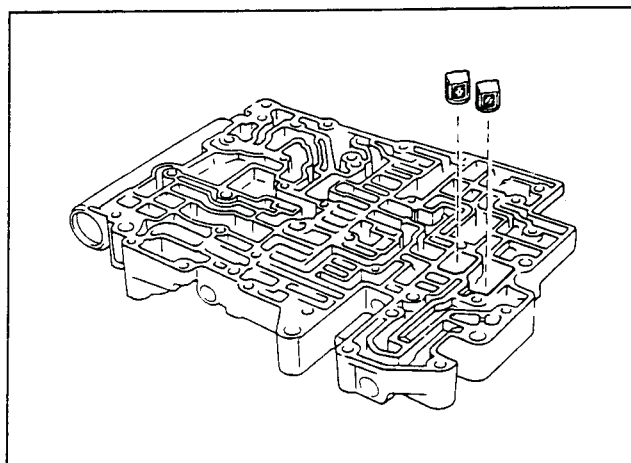



Technical Service Information

(Assembly of Valve Body)

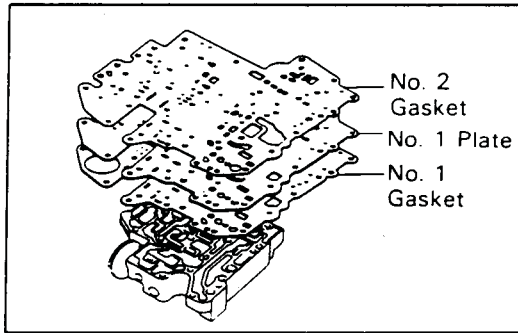

POSITION NO. 1 PLATE AND NEW GASKETS ON UPPER VALVE BODY

Position new No. 1 gasket, No. 1 plate and then new No. 2 gasket on the upper valve body.

NOTE: Since No. 1 gasket and No. 2 gasket are similar, use the illustration below to discriminate between them.

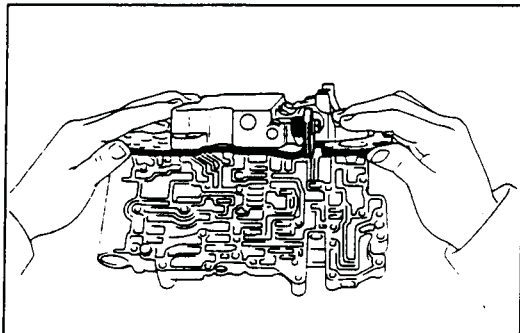
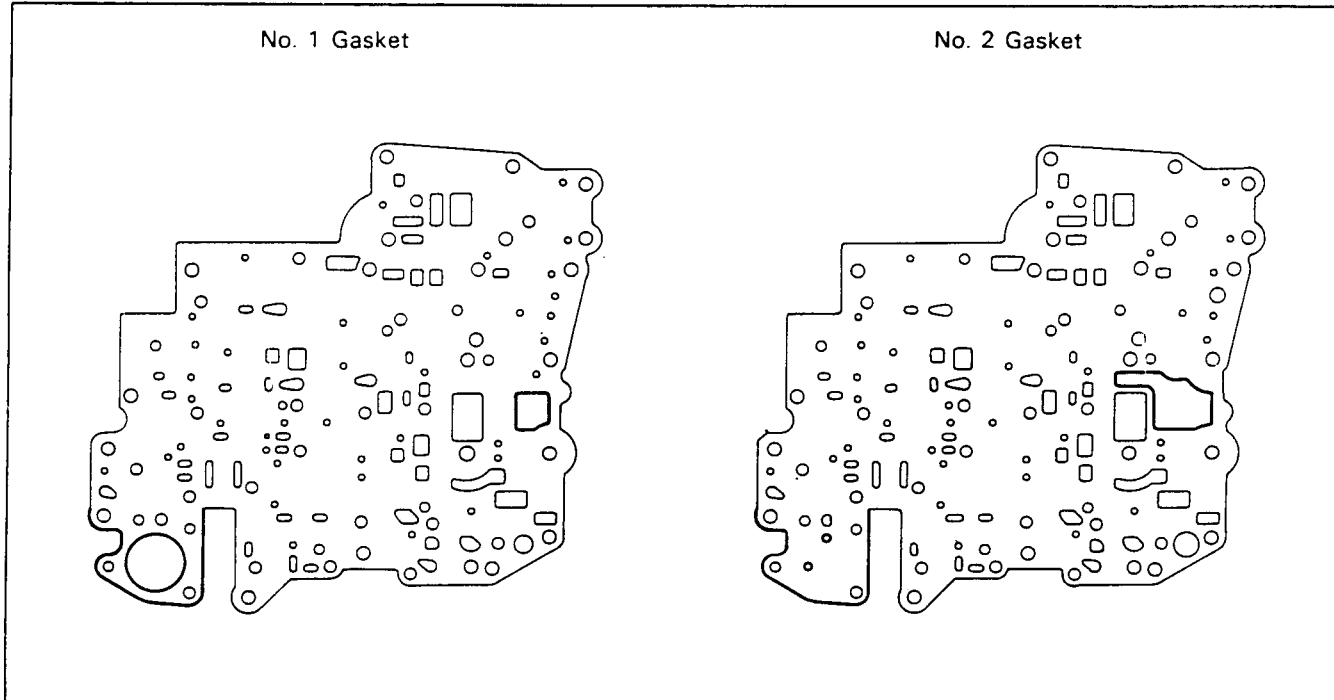

PLACE UPPER VALVE BODY WITH NO. 1 PLATE AND GASKETS ON LOWER VALVE BODY

Hold the upper valve body, No. 1 plate and gaskets securely so they do not separate.

Align each bolt hole in the valve bodies with the gaskets and plate.

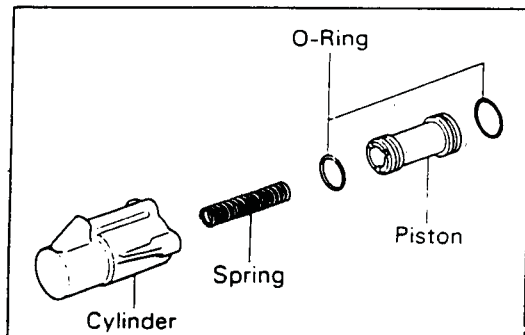

INSTALL B₀ ACCUMULATOR ASSEMBLY

Coat new O-rings with ATF and install them to the piston.

Insert the spring and piston into the cylinder.

Technical Service Information

Differential and Drive Pinion

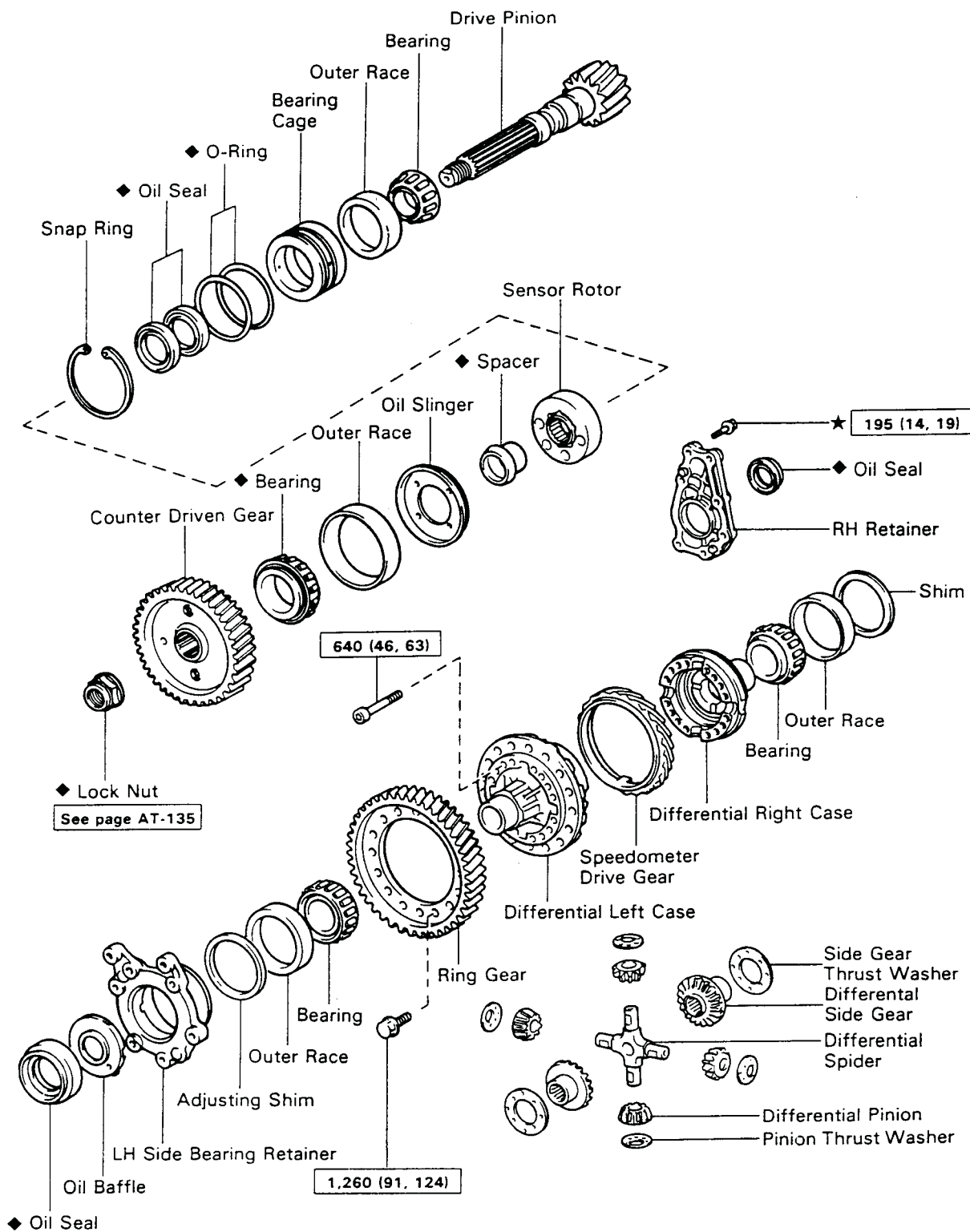

kg-cm (ft-lb, N.m) : Specified torque

◆ Non-reusable part

★ Precoated part



Technical Service Information

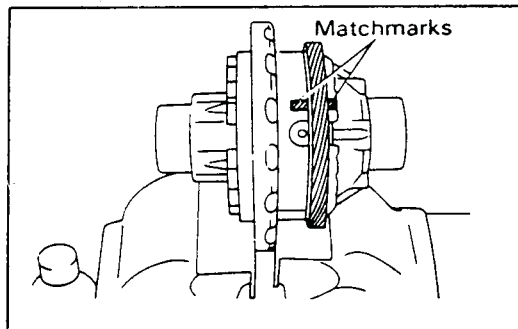

DIFFERENTIAL CASE

Place the matchmarks on the differential right and left case.

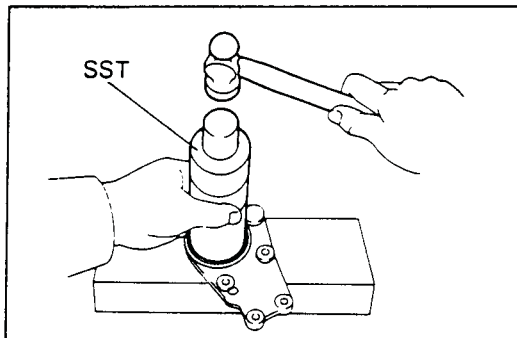

ASSEMBLY OF DIFFERENTIAL CASE

INSTALL RH OIL SEAL TO RH RETAINER

Using SST, drive in a new oil seal until its surface is flush with the surface of RH retainer.

SST 09316-60010 (09316-00010)

Coat the oil seal lip with MP grease.

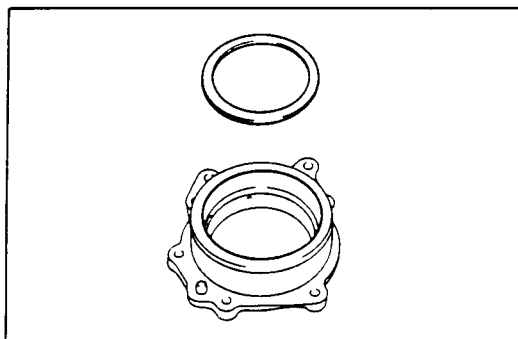

INSTALL ADJUSTING SHIM AND BEARING OUTER RACE TO LH BEARING RETAINER

Place the adjusting shim into the LH bearing retainer.

NOTE: Use either the shim which was removed or one 2.40 mm (0.0945 in.).

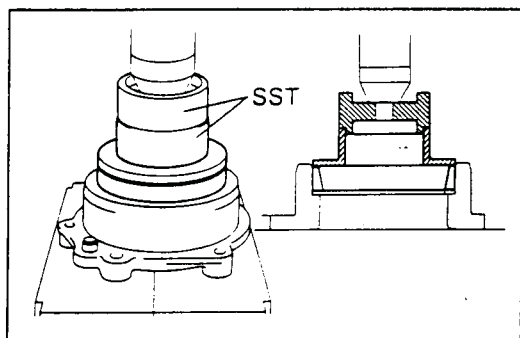

Using SST, press the outer race into the LH retainer.

SST 09316-20011, 09350-32014 (09351-32150)

NOTE: Install the oil baffle and oil seal after adjusting the differential side bearing preload

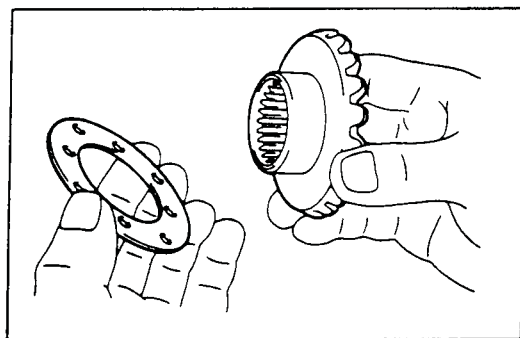

ASSEMBLE DIFFERENTIAL CASE

NOTE: Coat all of the sliding and rotating surface with ATF before assembly.

Install the thrust washer to the side gear.



Technical Service Information

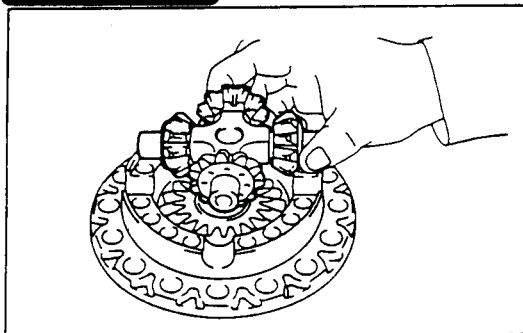

Install the four pinions and thrust washers to the spider.

Install the side gear and spider with four pinions to the differential left case.

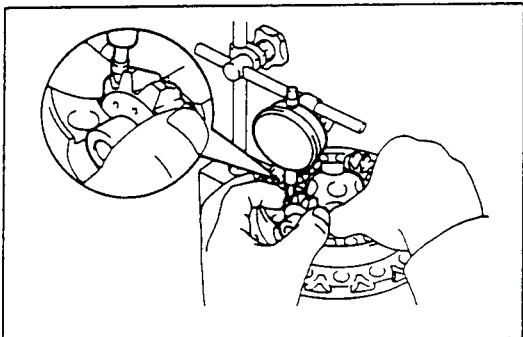

Using a dial indicator, measure the backlash of one pinion gear while holding the side gear.

**Standard backlash: 0.05 – 0.20 mm
(0.0020 – 0.0079 in.)**

Install the side gear and spider with four pinions to the right side of the differential case.

And check the side pinion backlash.

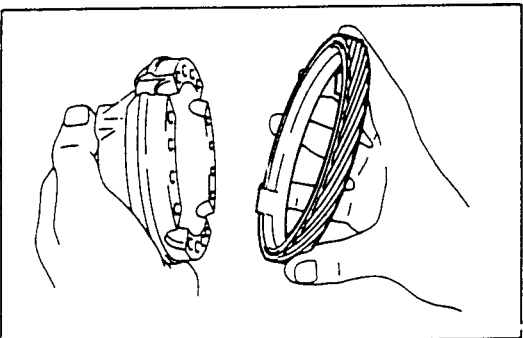

Referring to the table below, select the side gear thrust washer which will ensure that the backlash is within specification. Try to select a washer of the same size.

Thickness		mm (in.)
0.80 (0.0315)	1.20 (0.0472)	
0.90 (0.0354)	1.30 (0.0512)	
1.00 (0.0394)	1.40 (0.0551)	
1.10 (0.0433)		

Install the speedometer driven gear.

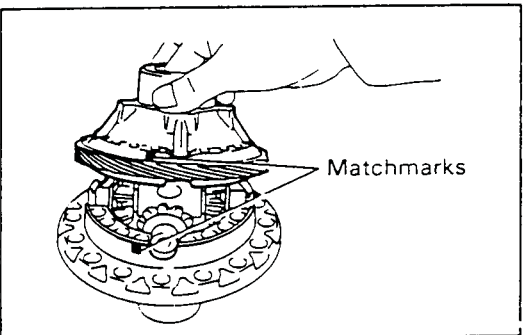

Align the matchmarks on the differential cases.

Using plastic hammer, carefully tap the differential case.

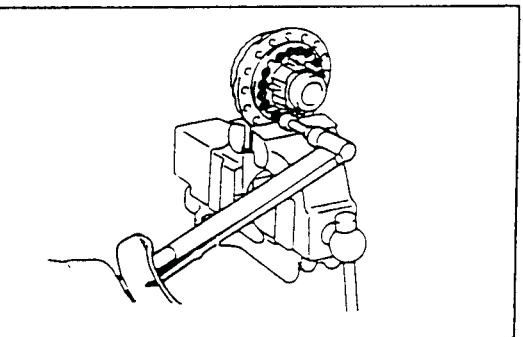

Using a torx wrench, install and torque the sixteen torx screws.

Torque: 640 kg-cm (46 ft-lb, 63 N·m)

ASSEMBLY OF DRIVE PINION SHAFT COMPONENTS

INSTALL COUNTER DRIVEN GEAR BEARING

Using SST, press in a new bearing.
SST 09350-32014 (09351-32090)

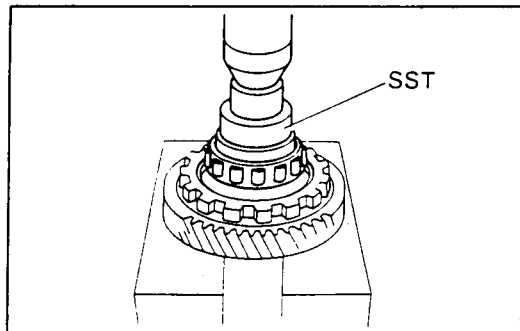

INSTALL OIL SEALS TO CAGE

Using SST, press in a new oil seal with the lip facing downward.

SST 09325-12010

Oil seal press in depth (from flat end):
8 mm (0.31 in.)

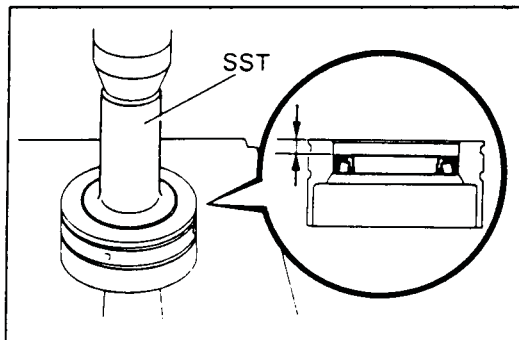

Check the oil seal press in depth.

Oil seal press in depth: 4.3 mm (0.169 in.)

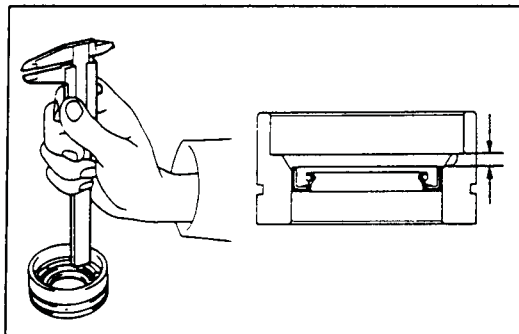

With the oil seal lip facing upward, use SST to press in a new oil seal until its end is flush with the surface of the cage.

SST 09325-12010

Coat the oil seal lips with MP grease.

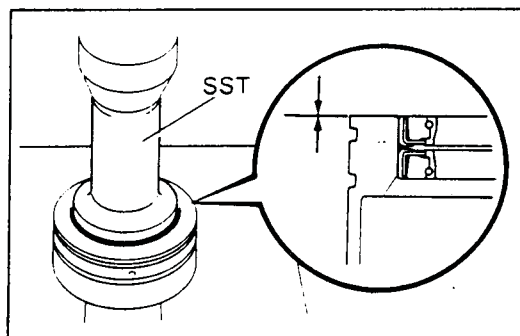

INSTALL SHAFT BEARING OUTER RACE TO CAGE

Using SST, press the outer race into the cage.
SST 09350-32014 (09351-32111)

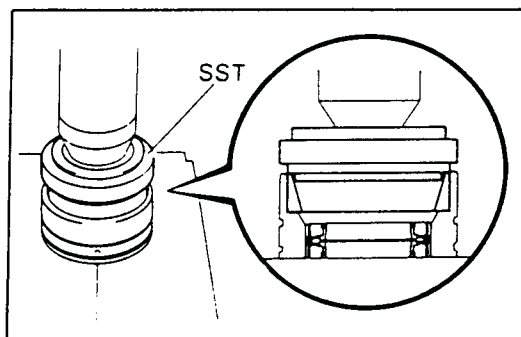



Technical Service Information

8. Be sure to install the thrust bearings and races in the correct direction and position.

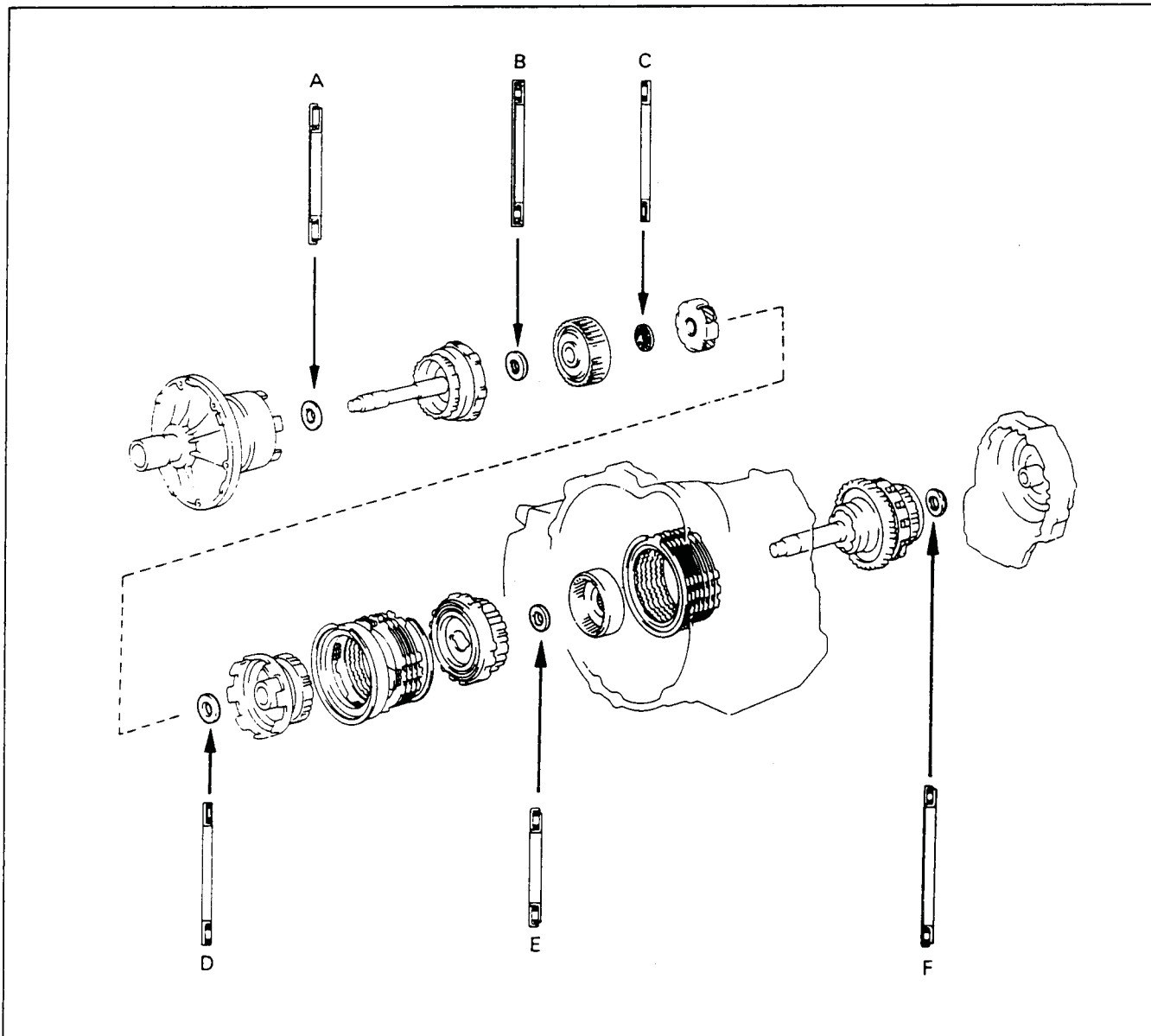

		Thrust bearing diameter					mm (in.)
		A	B	C	D	E	F
Bearing (with race)	Outer diameter	See page AT-148	47.6 (1.874)	45.5 (1.791)	←	38.7 (1.524)	54.0 (2.126)
	Inner diameter	27.7 (1.091)	31.4 (1.236)	30.1 (1.185)	←	22.6 (0.890)	39.4 (1.551)

AUTOMATIC TRANSMISSION SERVICE GROUP



Technical Service Information

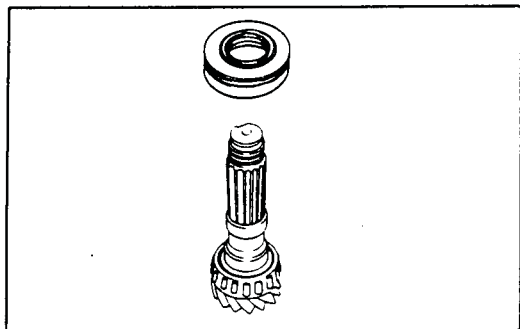

INSTALLATION OF DIFFERENTIAL AND DRIVE PINION

INSTALL DRIVE PINION INTO TRANSAXLE CASE

Place the bearing cage onto the drive pinion shaft.

CAUTION: Be careful not to damage the oil seals with the pinion shaft.

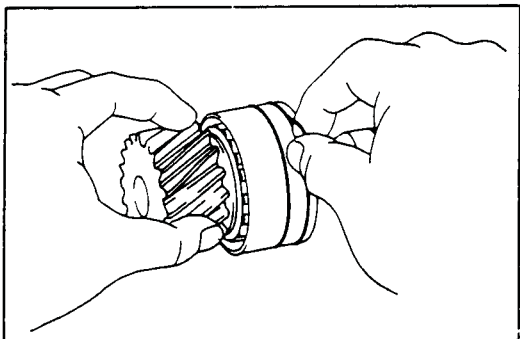

Install the two new O-rings to the bearing cage.

Coat the O-rings with ATF.

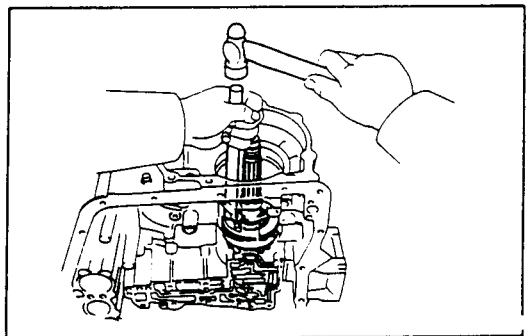

Using a hammer and brass bar, slightly tap the cage into the transaxle case until the snap ring groove in the bore can be seen.

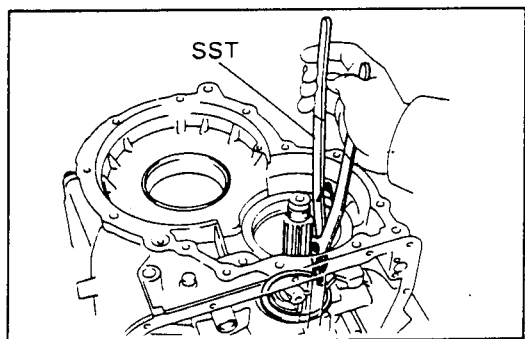

Using SST, install snap ring into the bore.
SST 09350-32014 (09351-32050)

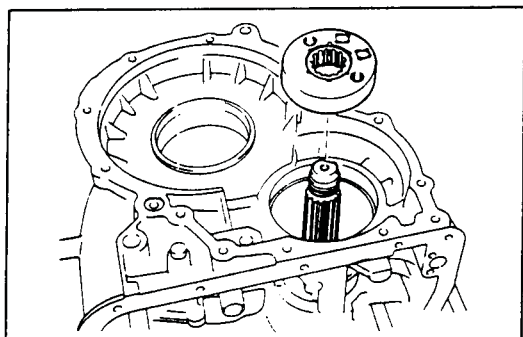

PLACE SENSOR ROTOR ONTO DRIVE PINION SHAFT



Technical Service Information

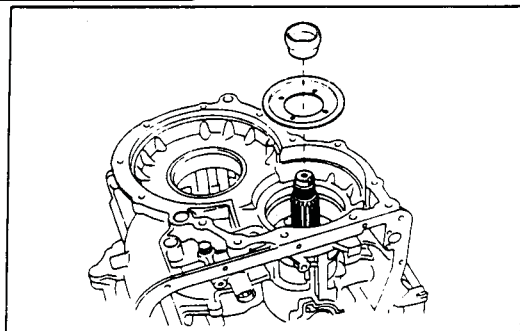

PLACE OIL SLINGER AND NEW SPACER

NOTE: Install the spacer with the small end downward.

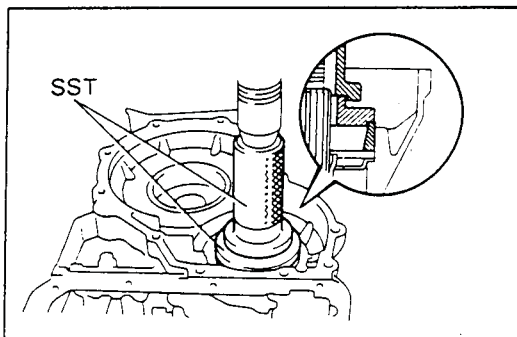

INSTALL OUTER RACE TO TRANSAXLE CASE

Using SST, press in the outer race.

SST 09350-32014 (09351-32100, 09351-32140)

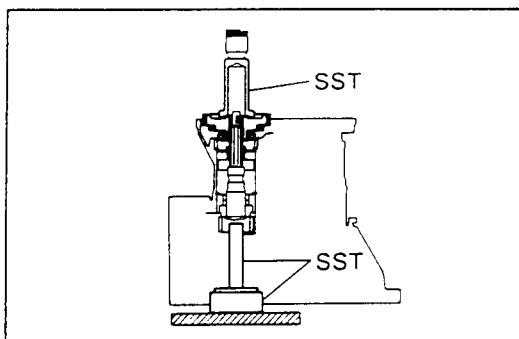

INSTALL COUNTER DRIVEN GEAR

Place SST into the transaxle hole to hold the drive pinion shaft.

SST 09350-32014 (09351-32130, 09351-32150)

Using SST, press in the counter driven gear until slightly thickness between the counter driven gear bearing and outer race.

SST 09350-32014 (09351-32140)

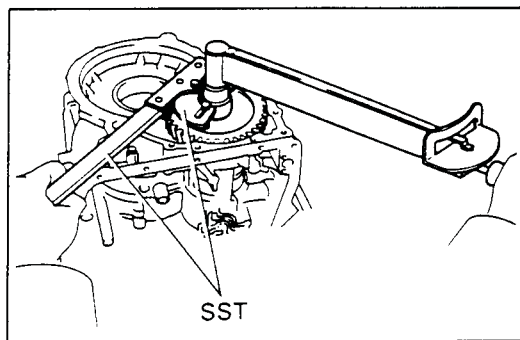

INSTALL NEW LOCK NUT AND ADJUST DRIVE PINION PRELOAD

Install the new lock nut.

Using SST to hold the gear, tighten the nut.

Torque: 2,100 kg-cm (152 ft-lb, 206 N·m)

SST 09330-00021, 09350-32014 (09351-32032)

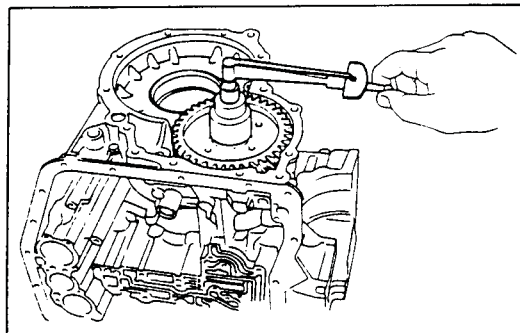

Turn the gear counterclockwise and clockwise several times.

Using a torque meter, measure the preload of the drive pinion.



Technical Service Information

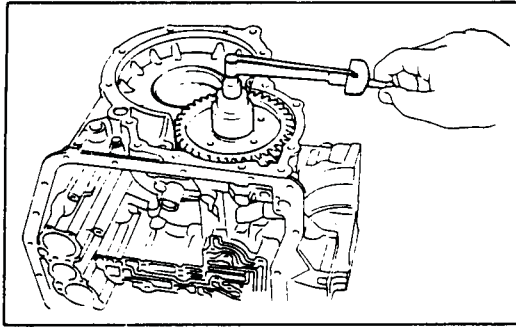

Drive pinion preload (at starting):

New bearing

10 – 16 kg-cm
(8.7 – 13.9 in.-lb, 1.0 – 1.6 N·m)

Reused bearing

5 – 8 kg-cm
(4.3 – 6.9 in.-lb, 0.5 – 0.8 N·m)

- If the preload is greater than specified, replace the bearing spacer.
- If the preload is less than specified, retighten the nut 130 kg-cm (9 ft-lb, 13 N·m) at a time until the specified preload is reached.

If the maximum torque is exceeded while retightening the nut, replace the bearing spacer and repeat the preload procedure.

Do not back off the nut to reduce the preload.

Maximum torque: 3,600 kg-cm (260 ft-lb, 353 N·m)

If the preload is adjusted within specification, make a note of it.

Stake the lock nut.

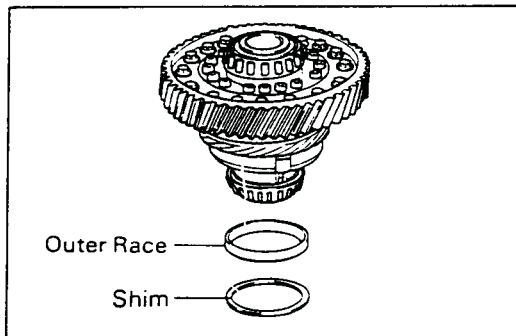
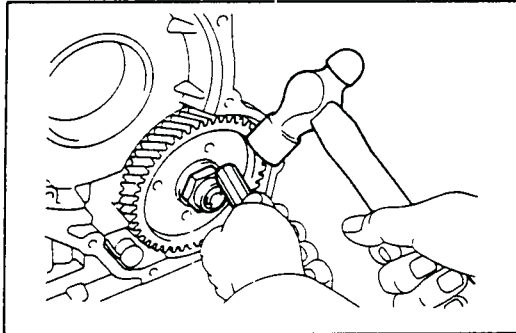

PLACE OUTER RACE AND SHIM ON TO RH SIDE BEARING

PLACE DIFFERENTIAL CASE INTO TRANSAXLE CASE

Be sure to install the shim and outer race into place.

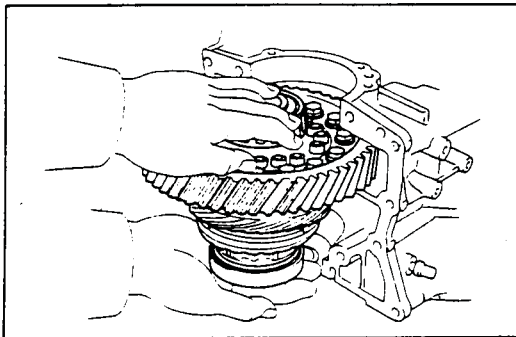

INSTALL CARRIER COVER

Remove any packing material and be careful not to drop oil on the contacting surfaces of the carrier cover and transaxle case.

Apply seal packing to the carrier cover as shown.

Seal packing: Part No. 08826-00090, THREE BOND 1281 or equivalent

NOTE: Install the carrier cover within ten minutes after applying seal packing.

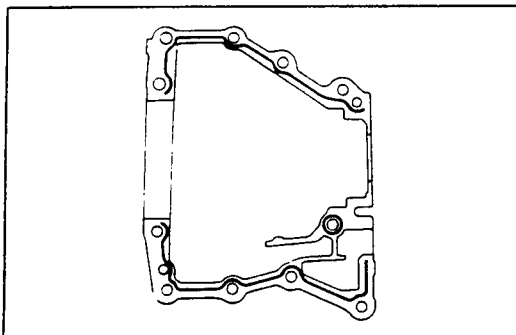



Technical Service Information

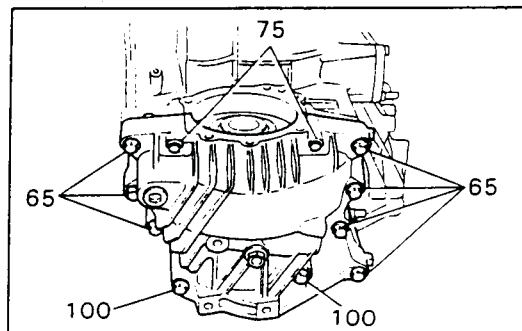

Install and torque the eleven bolts.

Torque: 400 kg-cm (29 ft-lb, 39 N·m)

NOTE: Each bolt length (mm) is indicated in the figure.

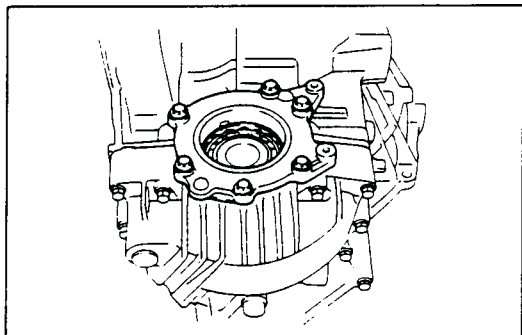

ADJUST SIDE BEARING PRELOAD

Remove any packing material on the contacting surfaces of the LH bearing retainer and transaxle case.

NOTE: Do not apply seal packing yet.

Install the LH bearing retainer and torque the six bolts.

Torque: 195 kg-cm (14 ft-lb, 19 N·m)

Snag down the bearings by turning the differential case several times.

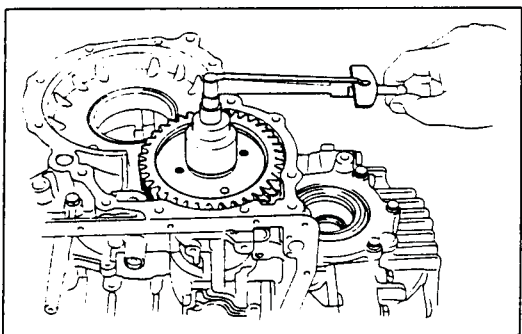

Using a torque meter, measure the differential total preload.

Total preload (at starting):

Add drive pinion preload

New bearing

2.8 – 4.4 kg-cm

(2.4 – 3.8 in.-lb, 0.3 – 0.4 N·m)

Reused bearing

1.4 – 2.2 kg-cm

(1.2 – 1.9 in.-lb, 0.1 – 0.2 N·m)

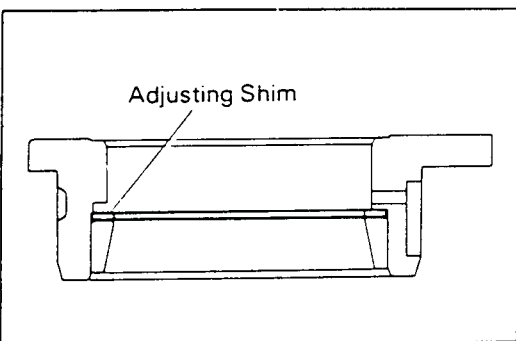

If the preload is not within specification, replace the adjusting shim in the LH bearing retainer with another thickness one.

Adjusting shim thickness		mm (in.)
2.00 (0.0787)	2.30 (0.0906)	2.60 (0.1024)
2.05 (0.0807)	2.35 (0.0925)	2.65 (0.1043)
2.10 (0.0827)	2.40 (0.0945)	2.70 (0.1063)
2.15 (0.0846)	2.45 (0.0965)	2.75 (0.1083)
2.20 (0.0866)	2.50 (0.0984)	2.80 (0.1103)
2.25 (0.0886)	2.55 (0.1004)	2.85 (0.1122)

INSTALL LH BEARING RETAINER

Remove the six bolts and LH bearing retainer.

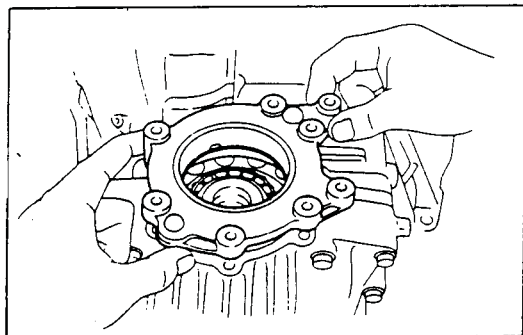



Technical Service Information

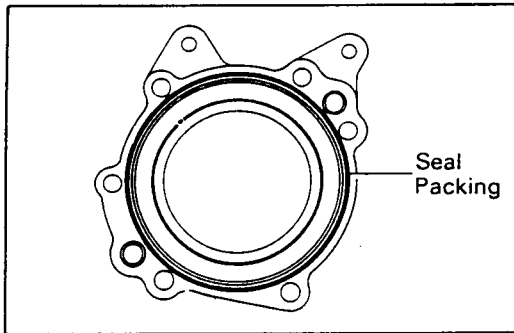

Apply the seal packing to the LH bearing retainer as shown.

Seal packing: Part No. 08826-00090, THREE BOND 1281 or equivalent

NOTE: Install the LH bearing retainer with ten minutes after applying seal packing.

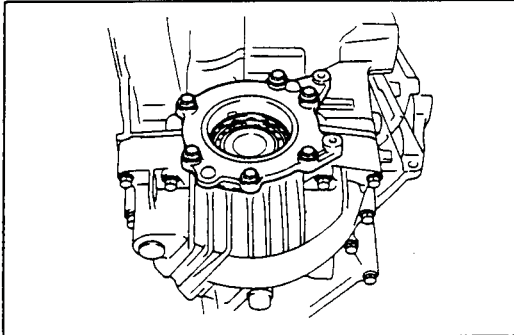

Install the LH bearing retainer.

Coat the threads of bolts with sealer.

Sealer: Part No. 08833-00070, THREE BOND 1324 or equivalent

Tighten the bolts.

Torque: 195 kg-cm (14 ft-lb, 19 N·m)

Snag down the bearings.

Recheck the differential total preload.

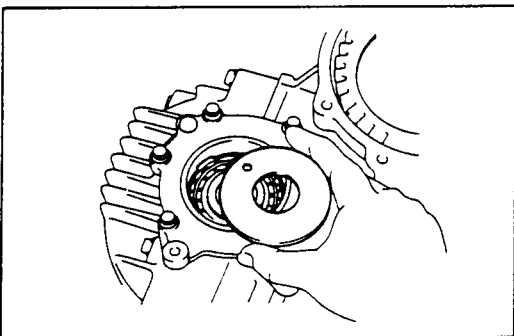

INSTALL NEW OIL SEAL

Place the oil baffle onto the LH bearing retainer.

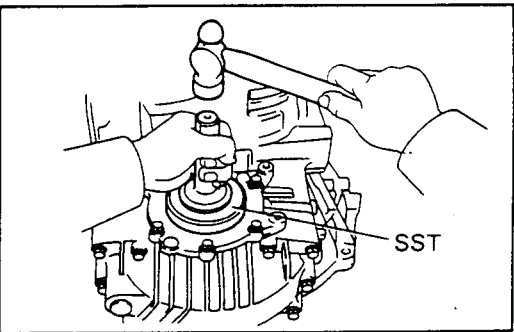

Using SST, driven in a new oil seal until its end is flush with the surface of the LH bearing retainer.

SST 09223-15010

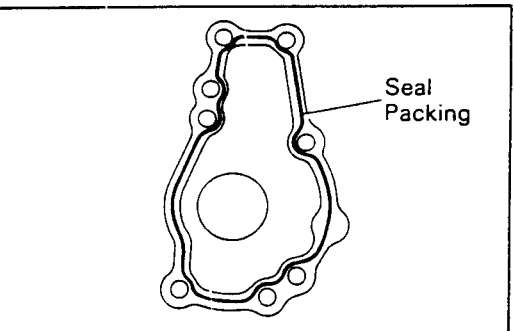

INSTALL RH RETAINER

(a) Remove any packing material on the contacting surfaces of RH retainer and transaxle case.

(b) Apply the seal packing to the RH retainer as shown.

Seal packing: Part No. 08826-00090, THREE BOND 1281 or equivalent

NOTE: Install the RH retainer within ten minutes after applying seal packing.



Technical Service Information

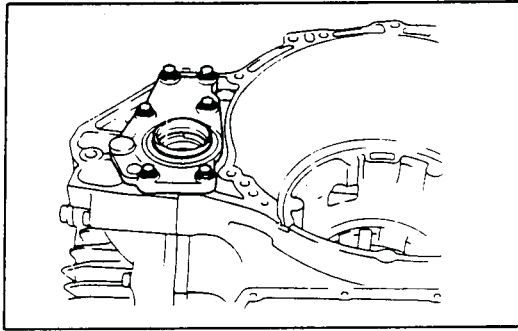

Coat the threads of bolts with sealer.

Sealer: Part No. 08833-00070, THREE BOND 1324 or equivalent

Tighten the bolts.

Torque: 195 kg-cm (14 ft-lb, 19 N·m)

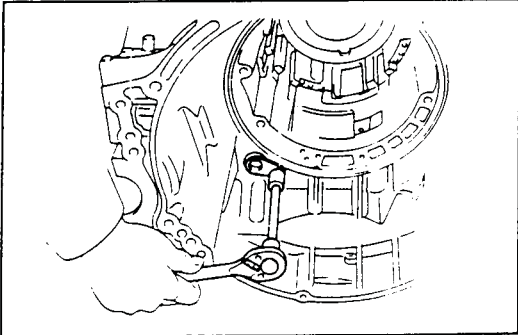

INSTALL DRIVE PINION CAP

Install a new O-ring to the cap.

Install the drive pinion cap to the transaxle case.

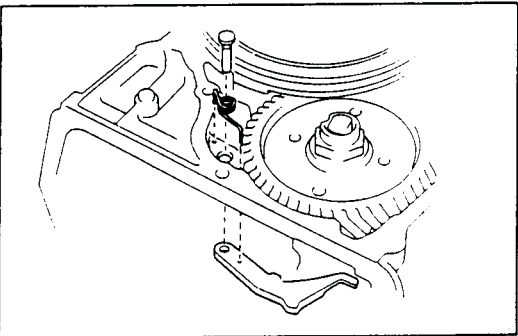

INSTALLATION OF 4-SPEED GEAR UNIT

INSTALL PARKING LOCK PAWL

Place the parking lock pawl onto the case.

Hook the spring ends to the case and pawl.

Install the pin into the hole of the case through the spring and pawl.

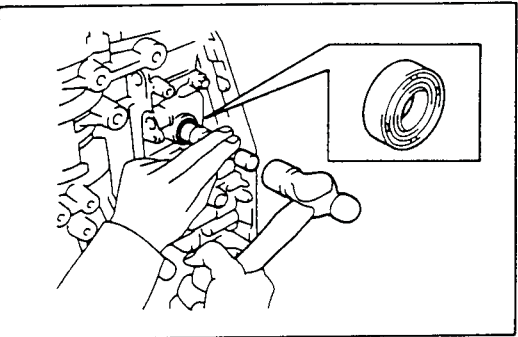

INSTALL MANUAL VALVE SHAFT

Install the manual valve shaft oil seal to the case.

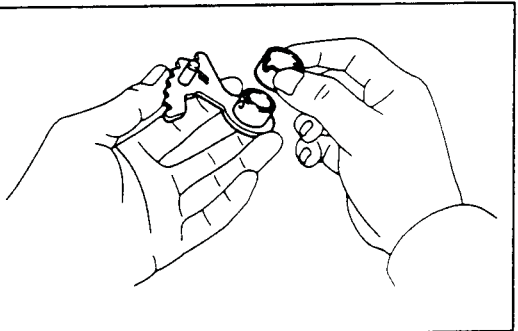

Assemble a new collar to the manual valve lever.



Technical Service Information

Install the manual valve shaft to the transmission case through the manual valve lever.

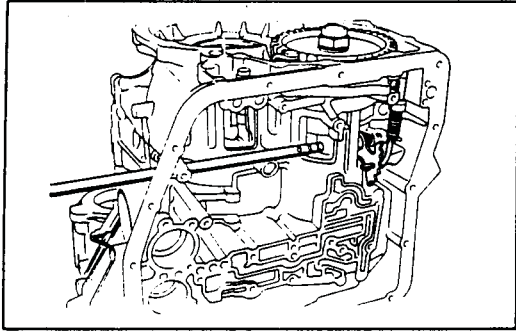

Using a pin punch, drive in the roll pin until its surface is flush with the manual valve lever surface.

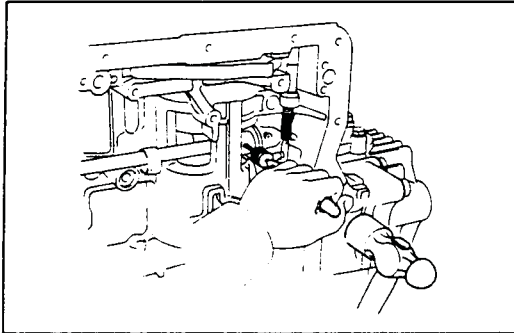

Match the collar hole to the lever calking hollow and calk the collar to the lever.

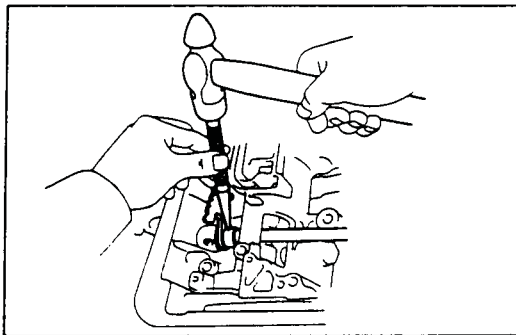

Install the retaining spring.

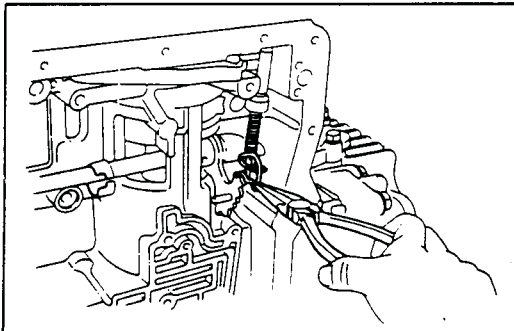

INSTALL PARKING LOCK PAWL BRACKET

Torque: 75 kg-cm (65 in.-lb, 7.4 N·m)

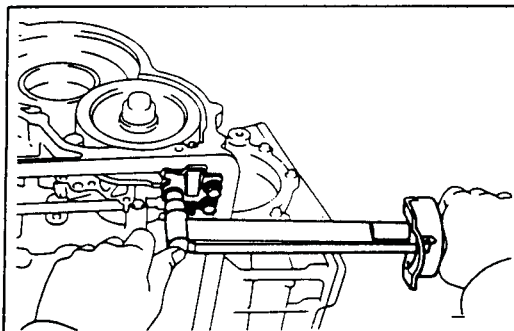



Technical Service Information

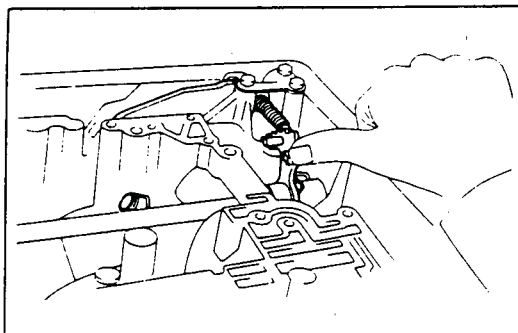

CHECK OPERATION OF PARKING LOCK PAWL

Make sure the counter driven gear is locked when the manual valve lever is in the P range.

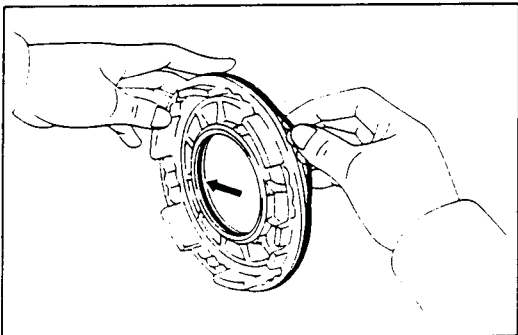

INSTALL FIRST AND REVERSE BRAKE PISTON TO TRANSMISSION CASE

Coat the new O-rings with ATF.

Install the two O-rings on the piston.

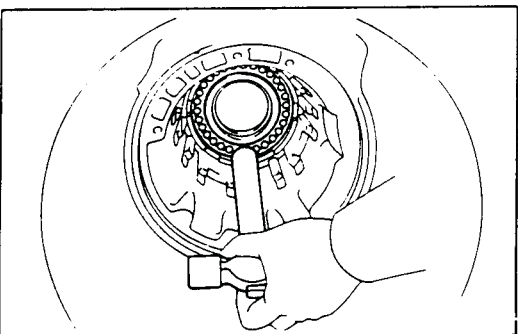

Push the piston into the bore of the case, facing the spring seat upward.

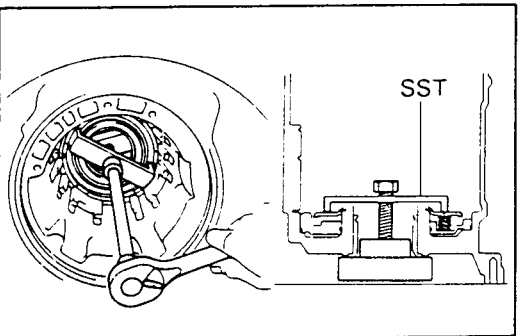

INSTALL PISTON RETURN SPRING

Place the return spring and snap ring on the piston.

Place SST, and compress the return spring evenly by tightening the bolt gradually.

SST 09350-32014 (09351-32040)

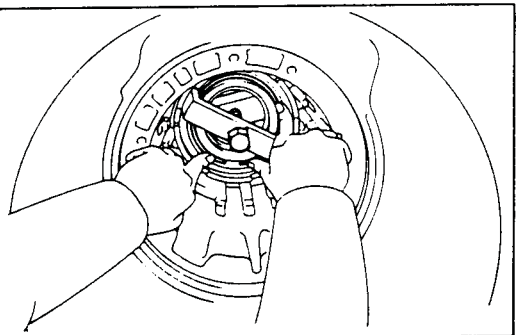

Install snap ring. Visually check to make sure it is fully seated and centered by the three lugs on the spring retainer.

Be sure the end gap of snap ring is not aligned with the spring retainer claw.

Remove SST.



Technical Service Information

INSTALL SNAP RING TO TRANSAXLE CASE

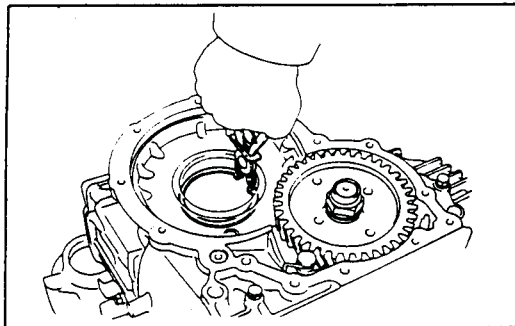

INSTALL OVERDRIVE UNIT

Install the overdrive brake apply gasket and overdrive clutch apply gasket.

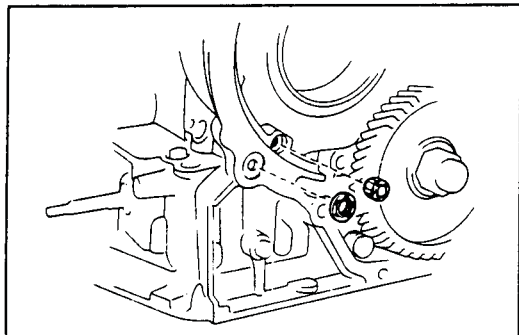

Install the overdrive brake drum to the case.
Install the new case gasket to the case.

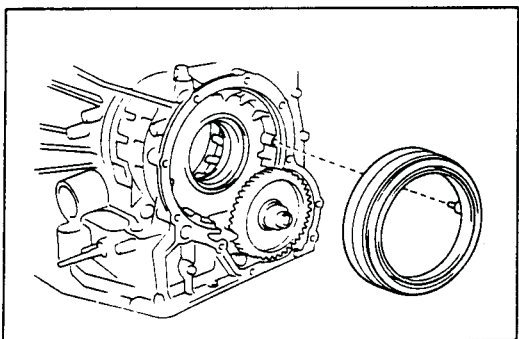

Make sure that the length from the top surface of the case to the counter driven gear top surface should be about 24 mm (0.94 in.).

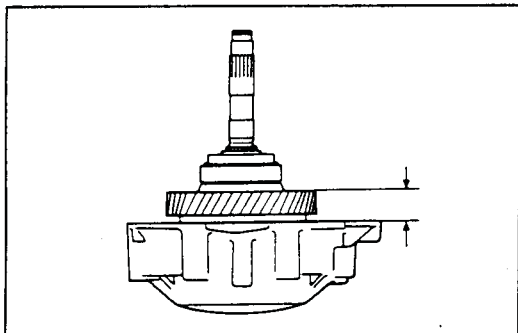

Place the new gasket onto the transaxle case.
Install the overdrive assembly with overdrive case to the transaxle case.

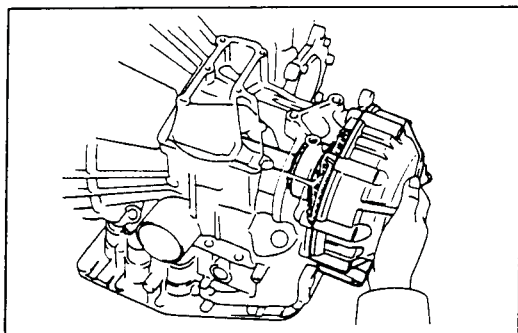



Technical Service Information

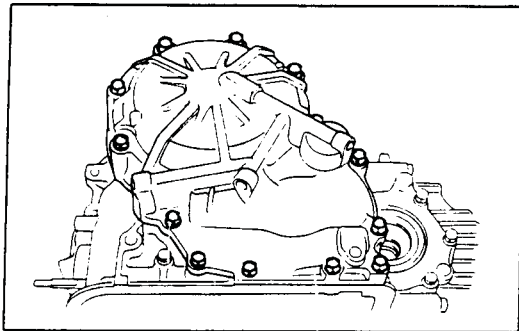

Install and tighten the bolts.
Torque: 250 kg-cm (18 ft-lb, 25 N·m)

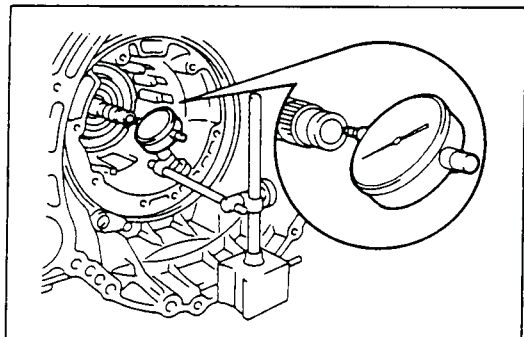

CHECK INTERMEDIATE SHAFT END PLAY

Make sure that the intermediate shaft has thrust play in axial direction.

Thrust play: 0.47 – 1.50 mm (0.0185 – 0.0591 in.)

If the thrust play is not within specification, check the installation of intermediate shaft.

Make sure that the intermediate shaft turns smoothly.

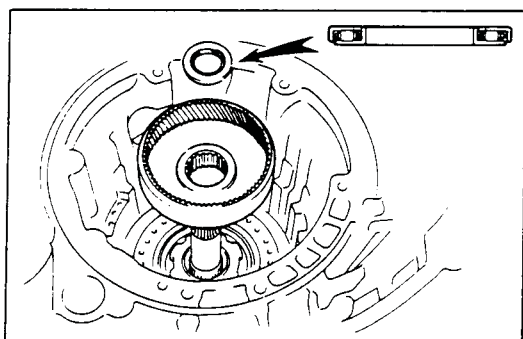

INSTALL REAR PLANETARY GEAR

- Install the rear planetary ring gear.
- Place the bearing onto the ring gear.

Bearing: Outer diameter 38.7 mm (1.524 in.)
Inner diameter 22.6 mm (0.890 in.)

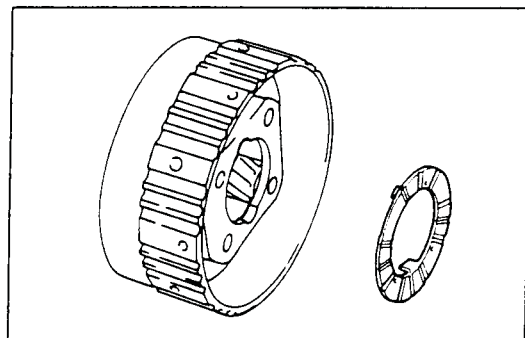

Coat the thrust washer with petroleum jelly and place it onto the rear planetary gear.

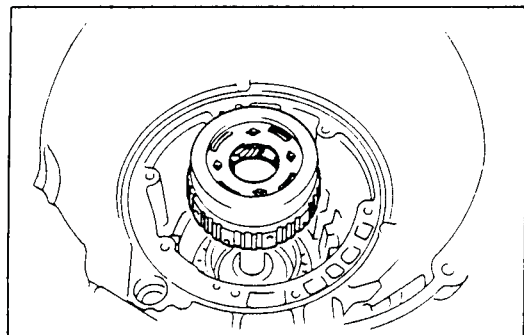

Install the rear planetary gear.



Technical Service Information

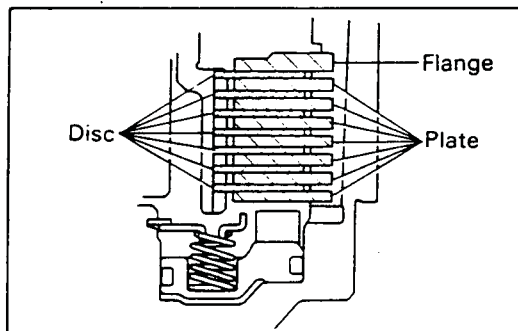

INSTALL DISCS, PLATES AND FLANGE OF FIRST AND REVERSE BRAKE

Install the seven plates and seven discs.

Install in order: P=Plate D=Disc
P-D-P-D-P-D-P-D-P-D-P-D

Install the flange, facing the flat end downward.

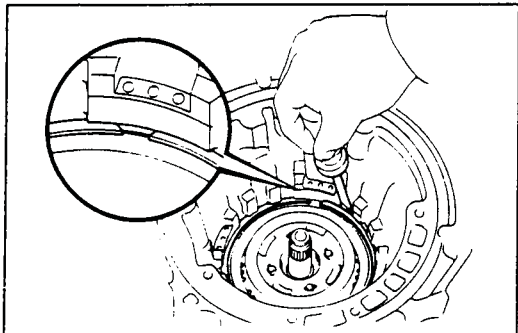

Install the snap ring.

NOTE: Be sure that the end gap of the snap ring is not aligned with one of cutouts.

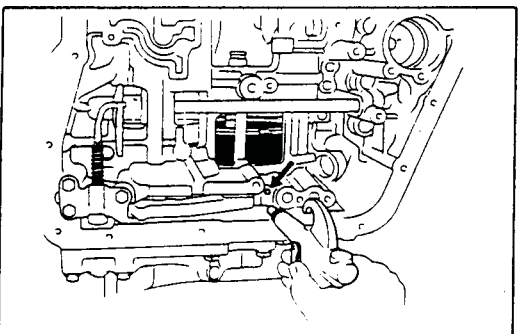

CHECK FIRST AND REVERSE BRAKE

Check the operation of the first and reverse brake piston.

Apply compressed air into the case passage and confirm that the piston moves.

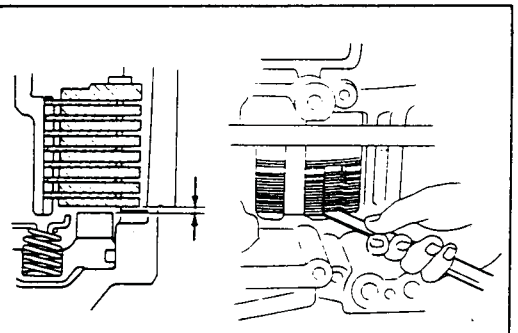

Using a filler gauge, check the pack clearance of the first and reverse brake.

Clearance: 0.85 – 2.05 mm (0.033 – 0.081 in.)

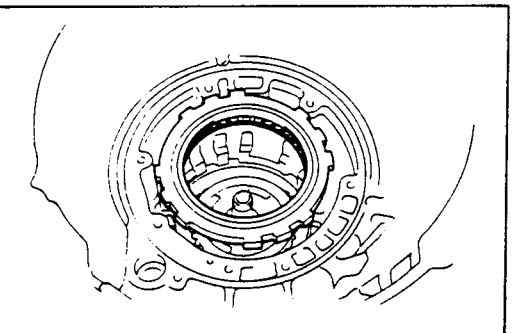

INSTALL NO. 2 ONE-WAY CLUTCH INTO CASE

Place the No. 2 one-way clutch with the shiny side of flange upward.



Technical Service Information

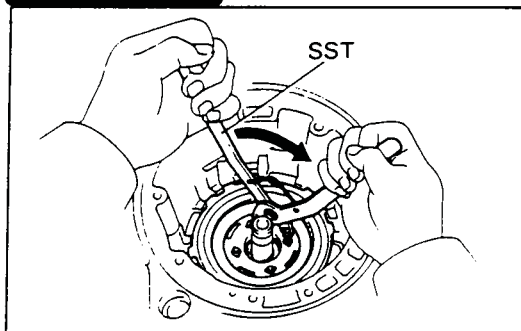

Install the one-way clutch while turning the planetary gear clockwise with SST.

SST 09350-32014 (09351-32050)

If can not turn the planetary gear clockwise, check the installation of the one-way clutch.

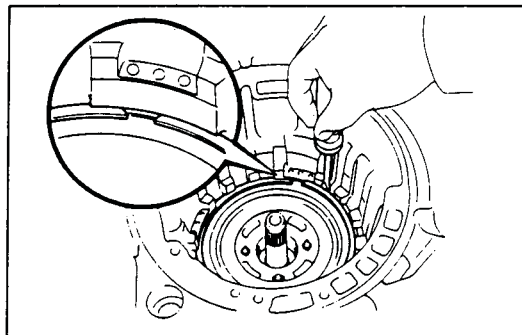

Install the snap ring.

NOTE: Be sure that the end gap of the snap ring is not aligned with one of cutouts.

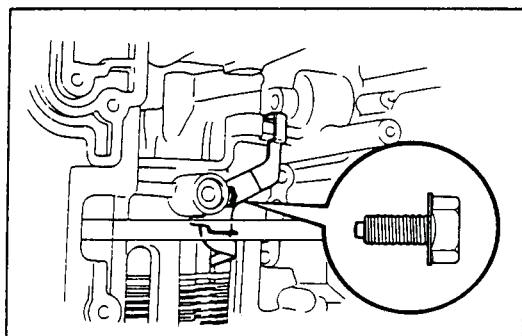

INSTALL SECOND COAST BRAKE BAND GUIDE

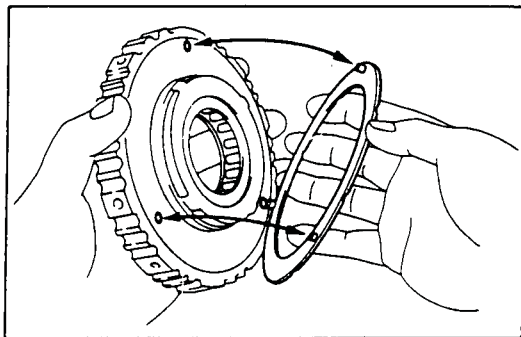

PLACE NO. 1 ONE-WAY CLUTCH

Coat the thrust washer with petroleum jelly and install it on the No. 1 one-way clutch.

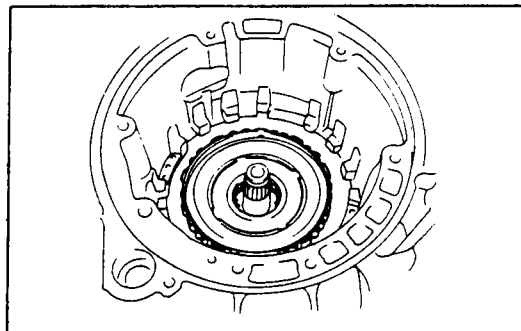

Place the No. 1 one-way clutch onto the rear planetary gear.



Technical Service Information

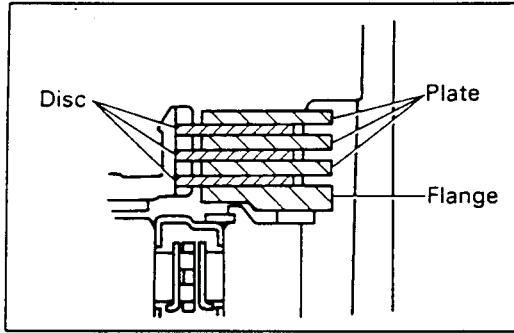

INSTALL SECOND BRAKE

Install the flange, facing the flat end upward.

Install the three discs and plates.

Install in order: P=Plate D=Disc
D-P-D-P-D-P

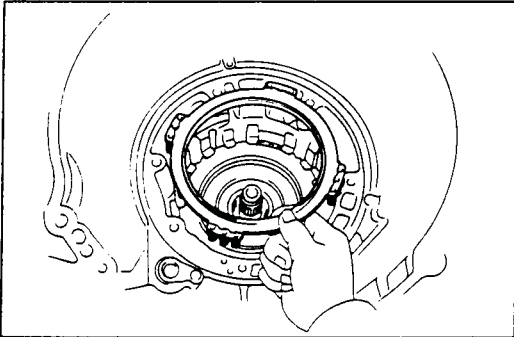

Place the piston return spring into the case.

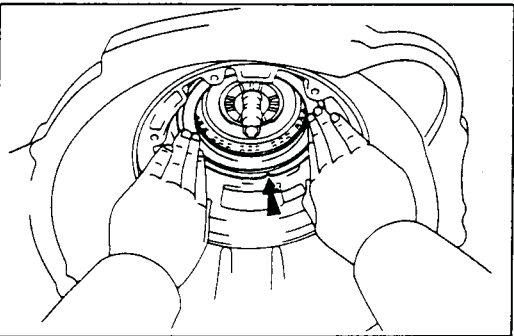

Place the second brake drum into the case.

NOTE: Align the groove of the drum with the bolt.

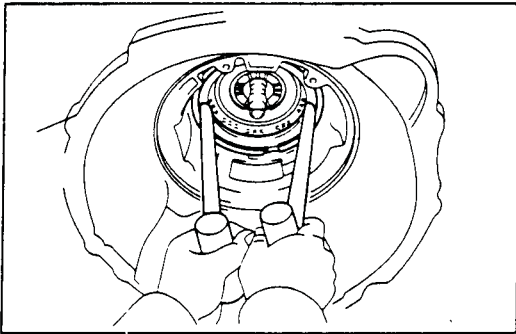

Place the snap ring into the case so that the end gap is installed into the groove.

While compressing the piston return springs over the drum with hammer handles, install the snap ring into the groove.

Be sure that the end gap of the snap ring is not aligned with one of cutouts.

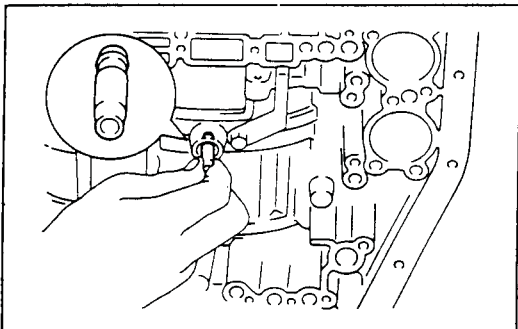

INSTALL NEW SECOND BRAKE GASKET

Install a new gasket until it makes contact with the second brake drum.



Technical Service Information

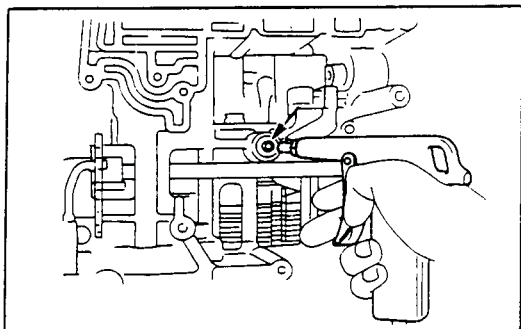

CHECK OPERATION OF SECOND BRAKE

Apply compressed air into the second brake gasket and confirm that the piston moves.

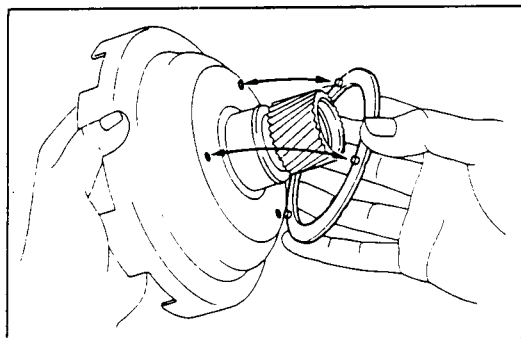

INSTALL SUN GEAR AND SUN GEAR INPUT DRUM

Coat the thrust washer with petroleum jelly and install it on the sun gear input drum.

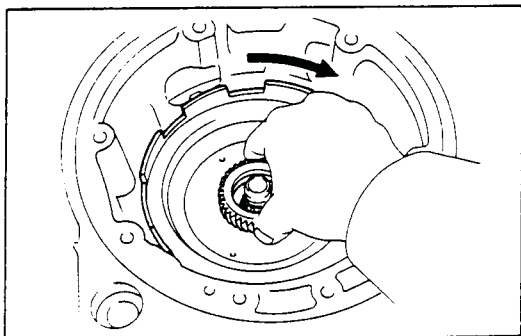

While turning the sun gear clockwise, install it into the one-way clutch.

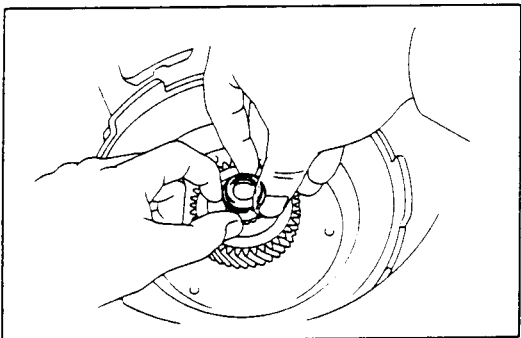

INSTALL OIL SEAL RING TO INTERMEDIATE SHAFT

NOTE: After installing the oil seal ring, check that it moves smoothly.

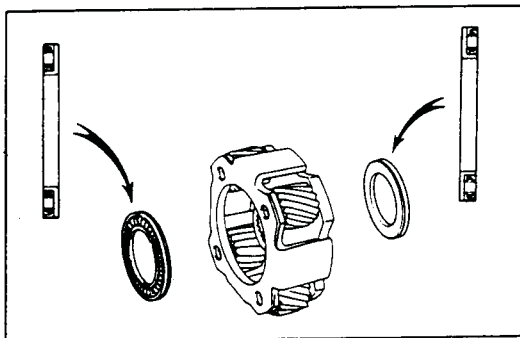

INSTALL FRONT PLANETARY GEAR

Coat the bearings with petroleum jelly, and install them onto the both sides of planetary gear.

Bearing: Outer diameter 45.5 mm (1.791 in.)
Inner diameter 30.1 mm (1.185 in.)

NOTE: The bearings are the same on the front and rear side.



Technical Service Information

Install the planetary gear onto the sun gear.

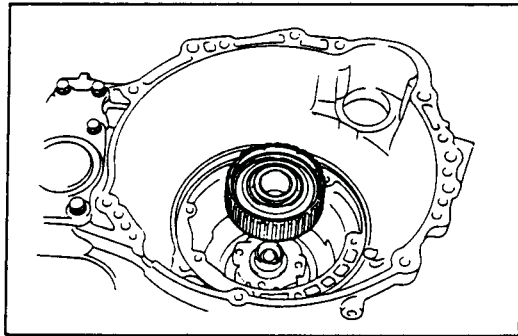
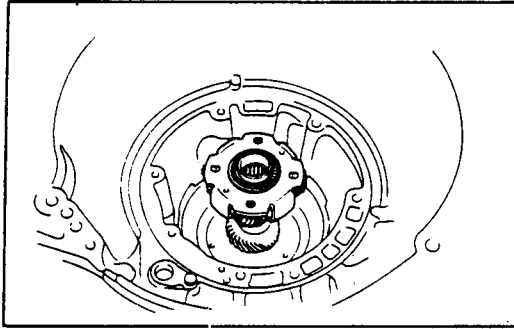

INSTALL FRONT PLANETARY RING GEAR

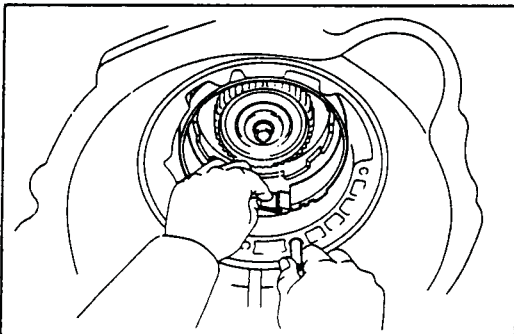

INSTALL SECOND COAST BRAKE BAND

Place the band into the case.

Install the pin through the oil pump mounting bolt hole.

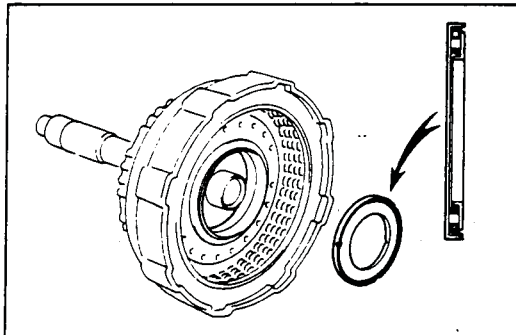

INSTALL FORWARD CLUTCH AND DIRECT CLUTCH

Coat the bearing with petroleum jelly and install it onto rear side of the forward clutch.

Bearing: Outer diameter 47.6 mm (1.874 in.)
Inner diameter 31.4 mm (1.236 in.)

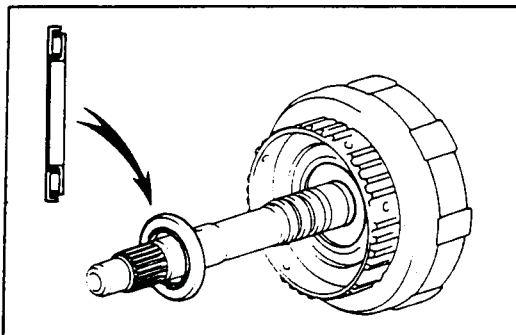

Coat the bearing with petroleum jelly and install it onto front side of the forward clutch.

NOTE: There are two different-thick bearings for adjustment of the input shaft thrust play.

Thickness	Outer diameter	Inner diameter
3.60 mm (0.1417 in.)	45.9 mm (1.807 in.)	27.7 mm (1.091 in.)
4.19 mm (0.1650 in.)	47.1 mm (1.854 in.)	27.7 mm (1.091 in.)



Technical Service Information

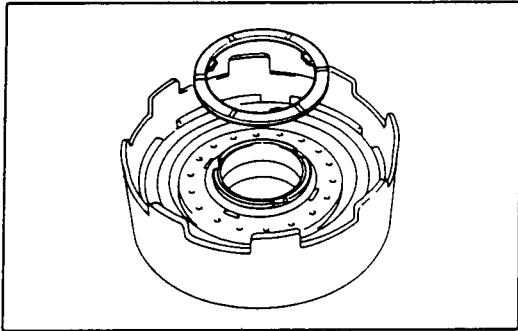

Coat the thrust washer with petroleum jelly and install it with the oil groove facing upward onto the direct clutch drum.

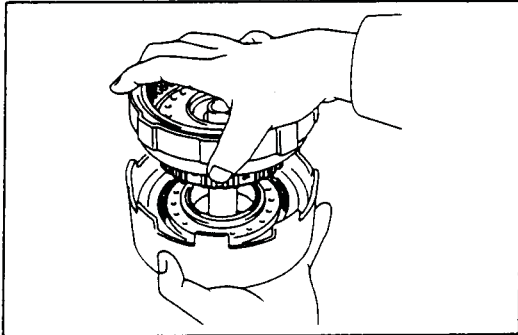

Mesh the hub of the forward clutch with flanges of the direct clutch discs.

NOTE: Be careful that the bearing and thrust washer do not get out of place.

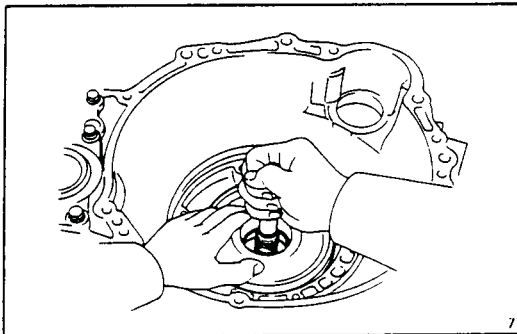

Install the direct clutch and forward clutch into the case.

NOTE: Hold the direct clutch toward the forward clutch to prevent the thrust washer from getting out of place.

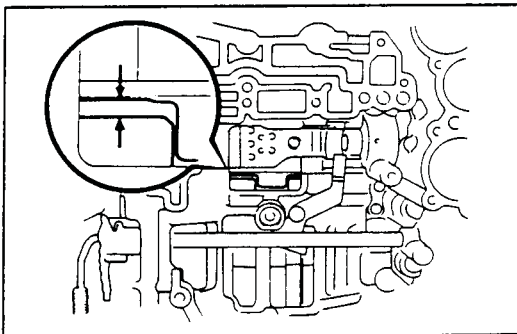

Check the distance between the direct clutch drum and the sun gear input drum.

Distance: Approx. 3 mm (0.12 in.)

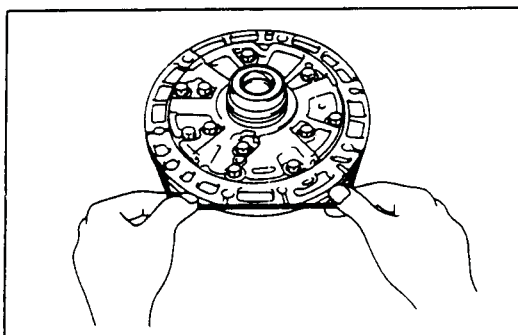

INSTALL OIL PUMP INTO CASE

Coat a new O-ring with ATF and install it to the oil pump.



Technical Service Information

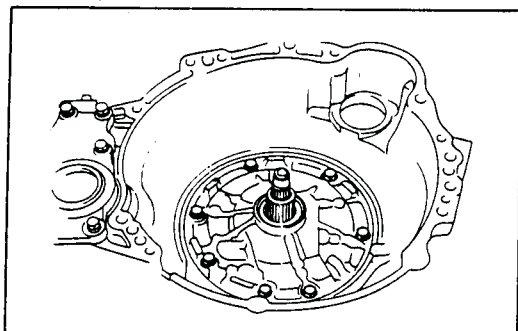

Place the oil pump through the input shaft, and align the bolt holes of the pump body with the transmission case.

CAUTION: Do not push on the oil pump strongly or the oil seal ring will stick to the direct clutch drum.

(c) Install and tighten the seven bolts.

Torque: 225 kg-cm (16 ft-lb, 22 N·m)

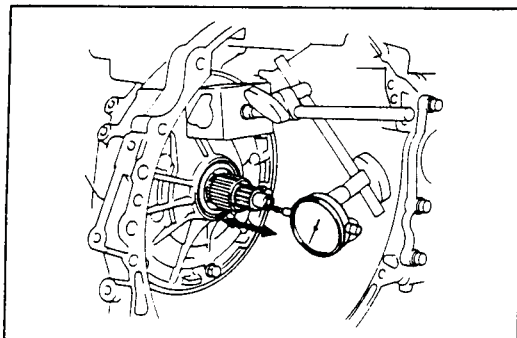

MEASURE THRUST PLAY OF INPUT SHAFT

Measure the thrust play with a dial gauge.

Thrust play: 0.13 – 0.90 mm (0.0051 – 0.0354 in.)

NOTE: There are two different-thick bearings for the end of stator shaft. If the thrust play is in excess of standard, select one of them.

Bearing thickness: 3.60 mm (0.1417 in.)
4.19 mm (0.1650 in.)

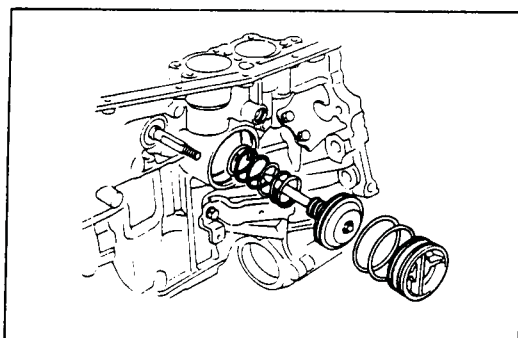

CHECK INPUT SHAFT ROTATION

Make sure that the input shaft rotates smoothly.

INSTALL SECOND COAST BRAKE PISTON

Coat the new O-rings with ATF and install it to the cover.

Install the outer spring with the piston.

Place the cover into the bore.

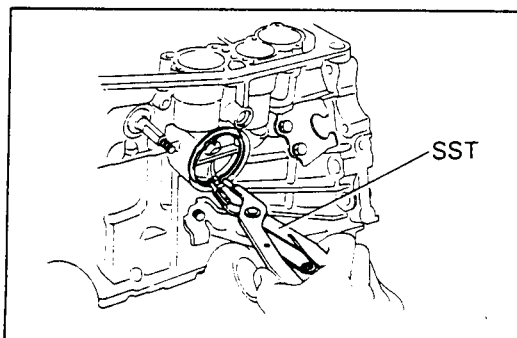

Using SST, install the snap ring while pressing the cover.

SST 09350-32014 (09351-32050)

Check that the front end of the piston rod contacts the center of the second brake band depression.

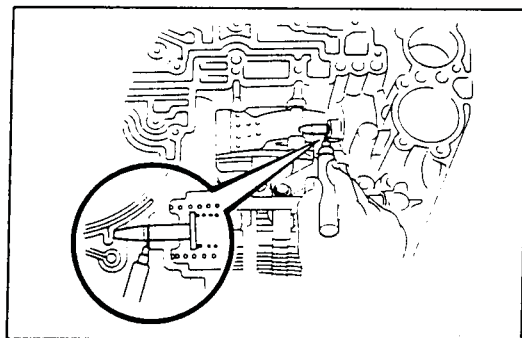

CHECK SECOND COAST BRAKE PISTON STROKE

Apply a small amount of paint to the piston rod at the point it meets the case as shown in the illustration.



Technical Service Information

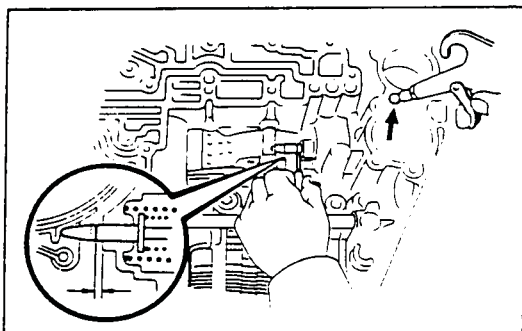

Using SST, measure the piston stroke applying and releasing the compressed air (4 – 8 kg/cm², 57 – 114 psi or 392 – 785 kPa) as shown.

SST 09240-00020

Piston stroke: 2.0 – 3.5 mm (0.079 – 0.138 in.)

If the stroke is more than specified, replace the piston rod with a longer one.

Piston rod length: 95.2 mm (3.748 in.)
96.3 mm (3.791 in.)

If it is still more than standard value, replace the brake band with a new one.

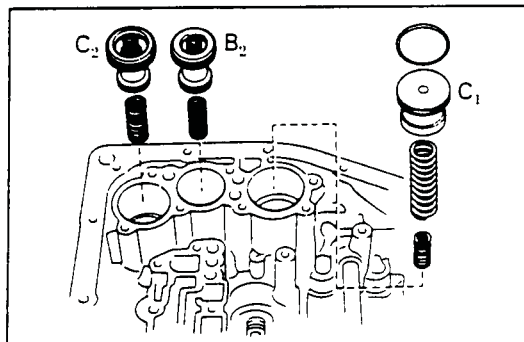

INSTALL ACCUMULATOR PISTONS AND SPRINGS

Install the new O-rings to the pistons.

Install the springs and pistons into the bores.

Spring	Free length mm (in.)	Outer diameter mm (in.)	Color	
C ₂	51.0 (2.008)	18.0 (0.709)	Red	
B ₂	58.5 (2.303)	15.2 (0.598)	Orange	
C ₁	Outer	71.2 (2.803)	24.4 (0.961)	Blue
	Inner	43.4 (1.709)	17.8 (0.701)	Light green

Place the cover with a new gasket and gradually tighten the bolts a little a time in sequence.

NOTE: Each bolt length (mm) is indicated in the figure.

Torque: 100 kg-cm (7 ft-lb, 10 N·m)

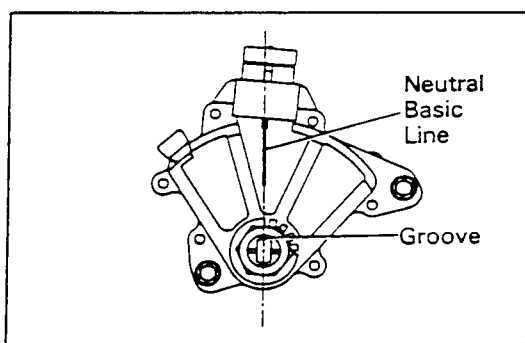
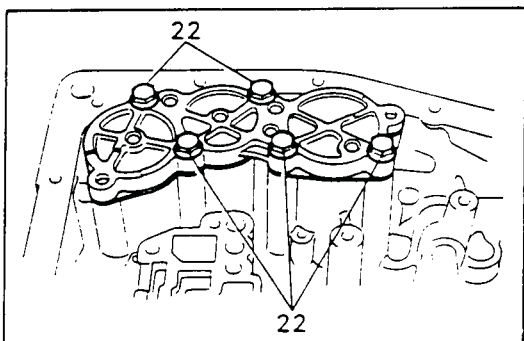

INSTALL NEUTRAL START SWITCH

Install the neutral start switch to the manual valve shaft.

Place the new locking plate and tighten the nut.

Stake the nut with locking plate.

Install the two bolts.

Adjust the neutral start switch.

NOTE: Align the groove and neutral basic line.

Tighten the two bolts.

INSTALL UNION AND ELBOW

Install the new O-rings to the union and elbow.

Install the union and elbow to the transaxle case.

Torque: 275 kg-cm (20 ft-lb, 27 N·m)

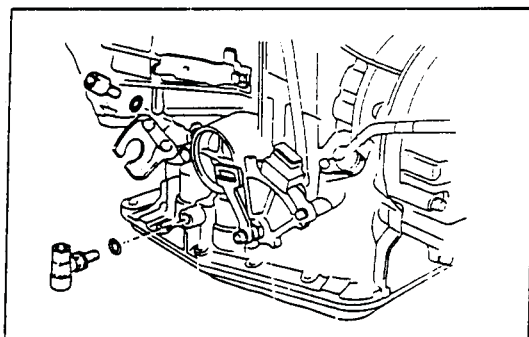

NOTE: Install the elbow at right angles to the bottom of the transaxle case.

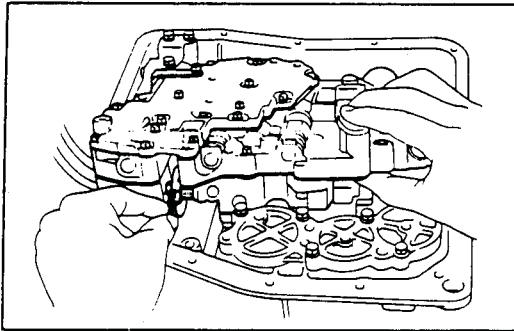

INSTALL VALVE BODY TO TRANSAXLE CASE

While holding the cam down with your hand, slip the cable end into the slot.

Lower the valve body into place.

CAUTION: Do not entangle the solenoid wire.

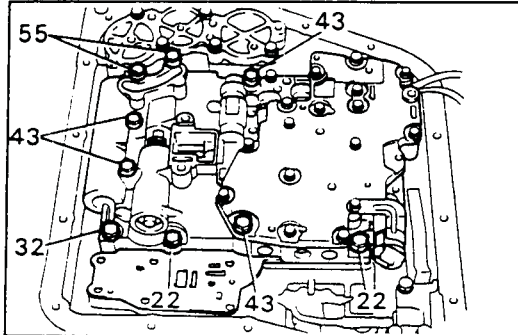

Install and tighten the nine bolts.

NOTE:

- Each bolt length (mm) is indicated in the figure.
- Hand tighten the nine bolts first, then torque with a torque wrench.

Torque: 110 kg-cm (8 ft-lb, 11 N·m)

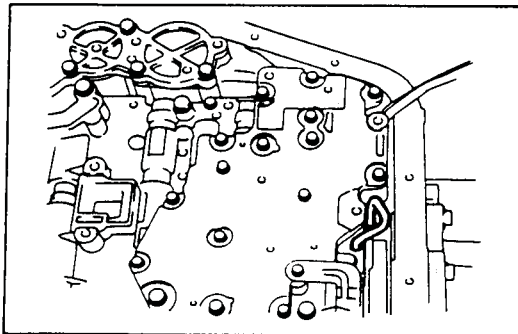

INSTALL B₃ APPLY TUBE

CAUTION: Be careful not to bend or damage the tube.

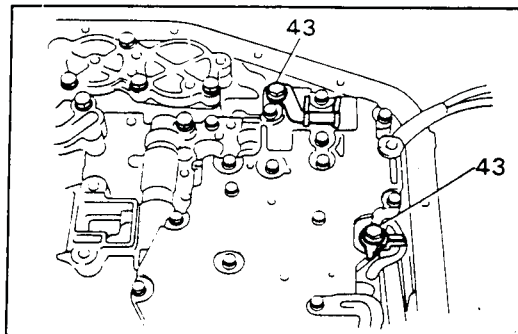

INSTALL CONNECTOR CLAMP AND TUBE RETAINER

NOTE: Each bolt length (mm) is indicated in the figure.

Torque: 110 kg-cm (8 ft-lb, 11 N·m)

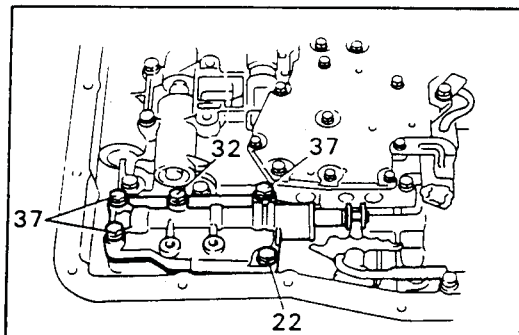

INSTALL MANUAL VALVE BODY AND DETENT SPRING

NOTE: Each bolt length (mm) is indicated in the figure.

Align the manual valve with the pin on the manual shaft lever.

Lower the manual valve body into place.

Hand tighten the five bolts first. Then, tighten them with a torque wrench.

Torque: 110 kg-cm (8 ft-lb, 11 N·m)



Technical Service Information

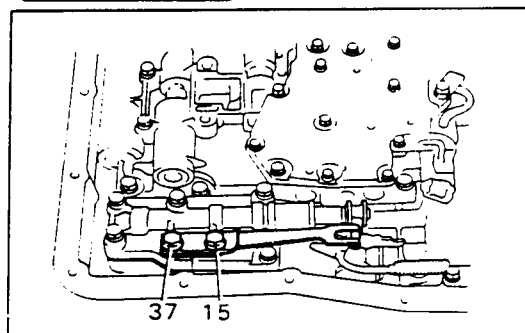

Place the detent spring on the manual valve body and hand tighten the two bolts first. Then, tighten them with a torque wrench.

Torque: 110 kg-cm (8 ft-lb, 11 N·m)

NOTE: Each bolt length (mm) is indicated in the figure.

Check that the manual valve lever is touching the center of the detent spring tip roller.

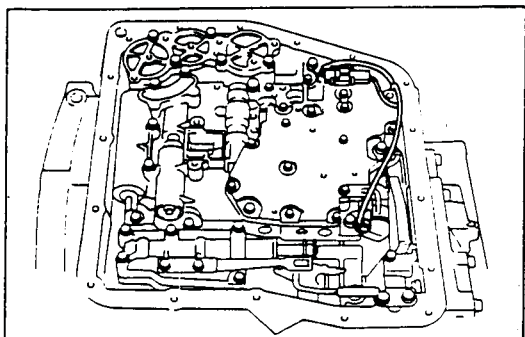

CONNECT SOLENOID CONNECTORS

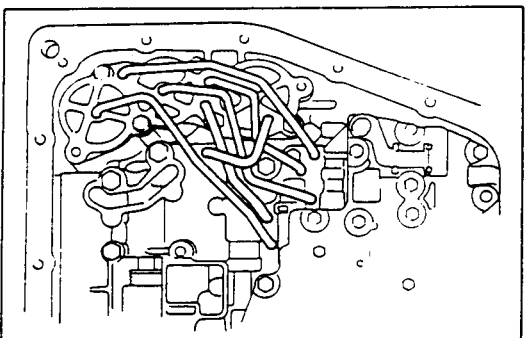

INSTALL OIL TUBES

Using a plastic hammer, install the tubes into the positions indicated in the figure.

CAUTION: Be careful not to bend or damage the tubes.

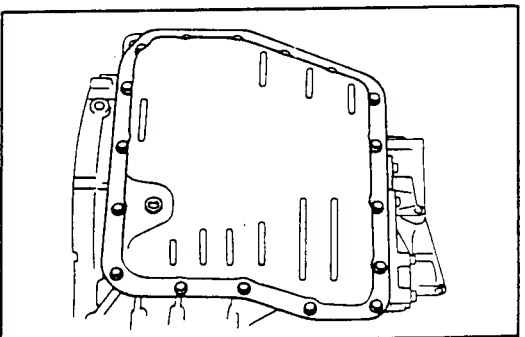

INSTALL OIL PAN WITH NEW GASKET

Torque: 50 kg-cm (43 in.-lb, 4.9 N·m)

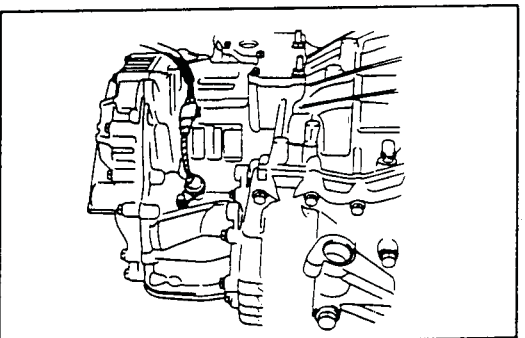

INSTALL SPEED SENSOR

Install a new O-ring to the speed sensor.

Install the speed sensor to the transaxle case.

Tighten the bolt.

Connect the sensor connector.



Technical Service Information

TOYOTA A540E TRANSMISSIONS

"UPPER" VALVE BODY AND ACCUMULATOR HOUSING

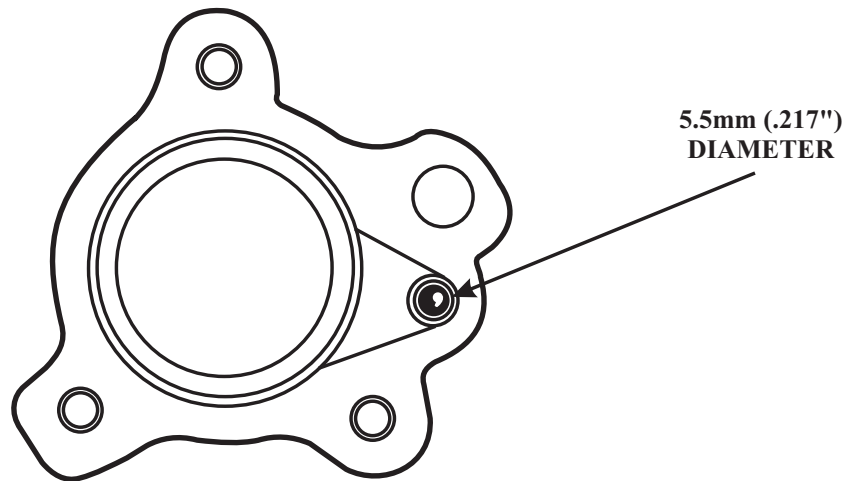
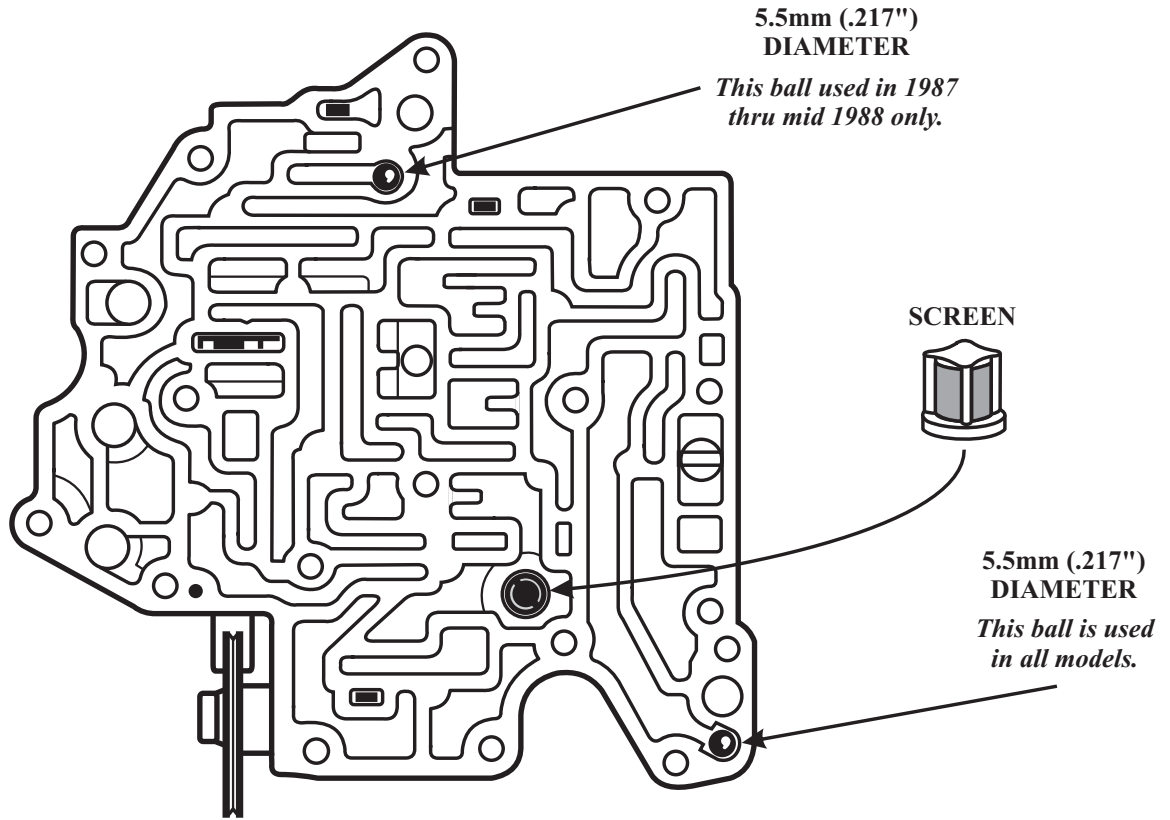



Technical Service Information

TOYOTA A540E TRANSMISSIONS

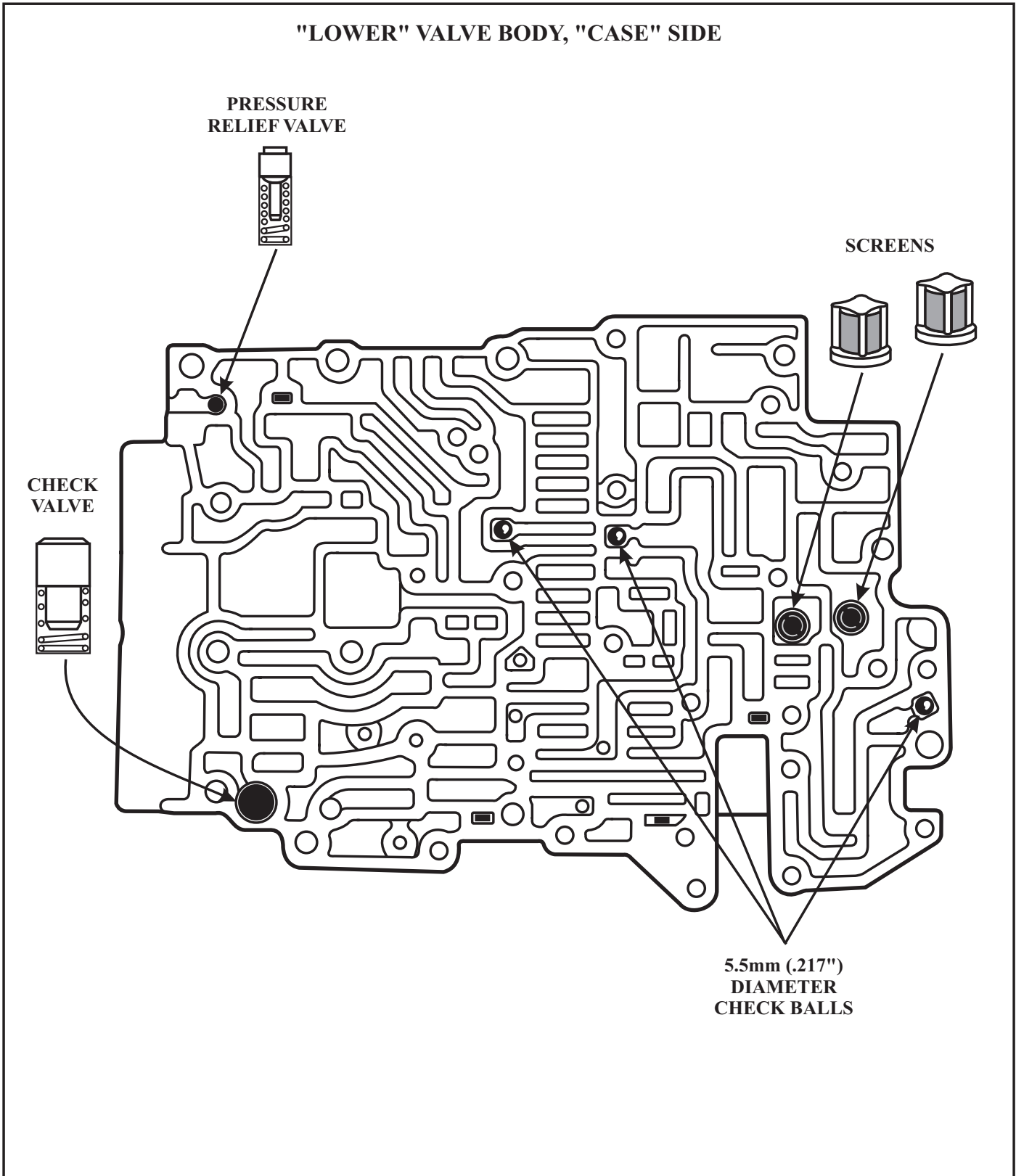



TOYOTA A540E TRANSMISSIONS

"LOWER" VALVE BODY, "FILTER" SIDE

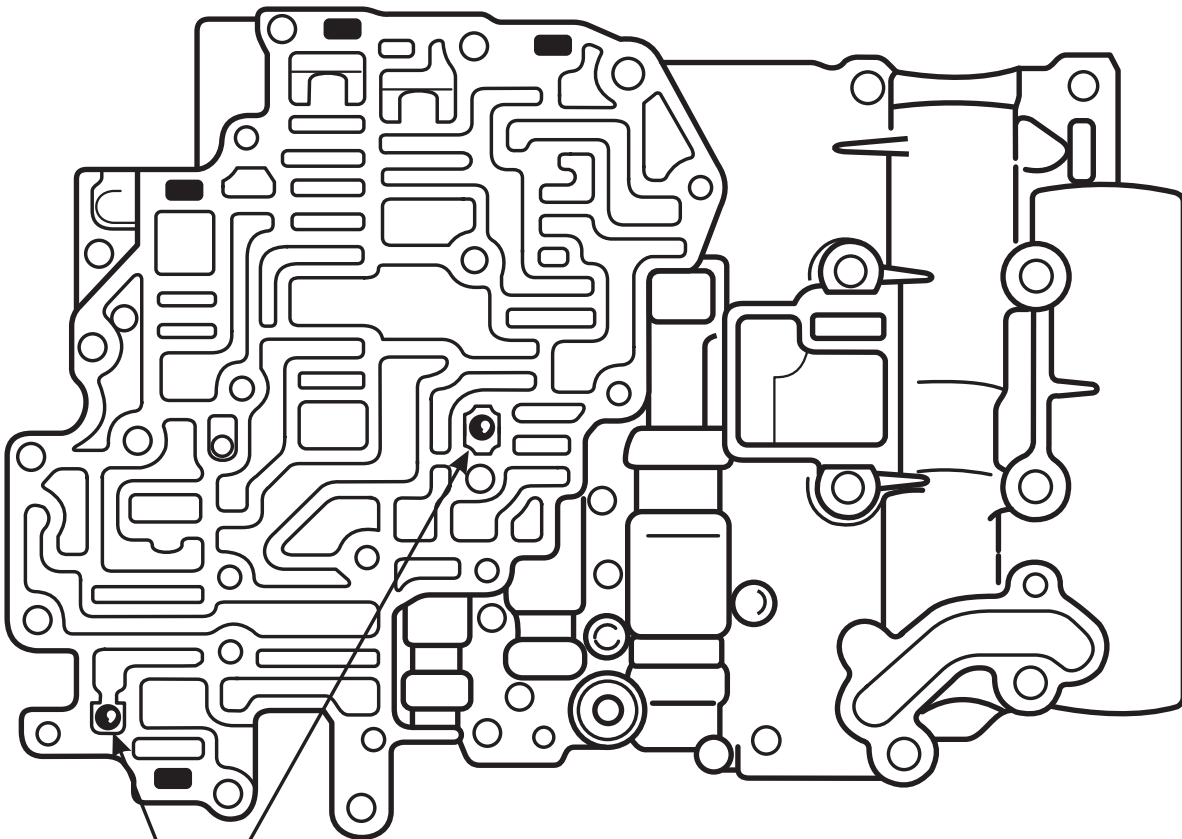

5.5mm (.217")
DIAMETER
CHECK BALLS

**TOYOTA A540 SERIES
LOW ONE-WAY CLUTCH**

***THE PLANETARY MUST FREEWHEEL COUNTER CLOCKWISE
AND LOCK CLOCKWISE WHEN THE OUTER RACE IS HELD***

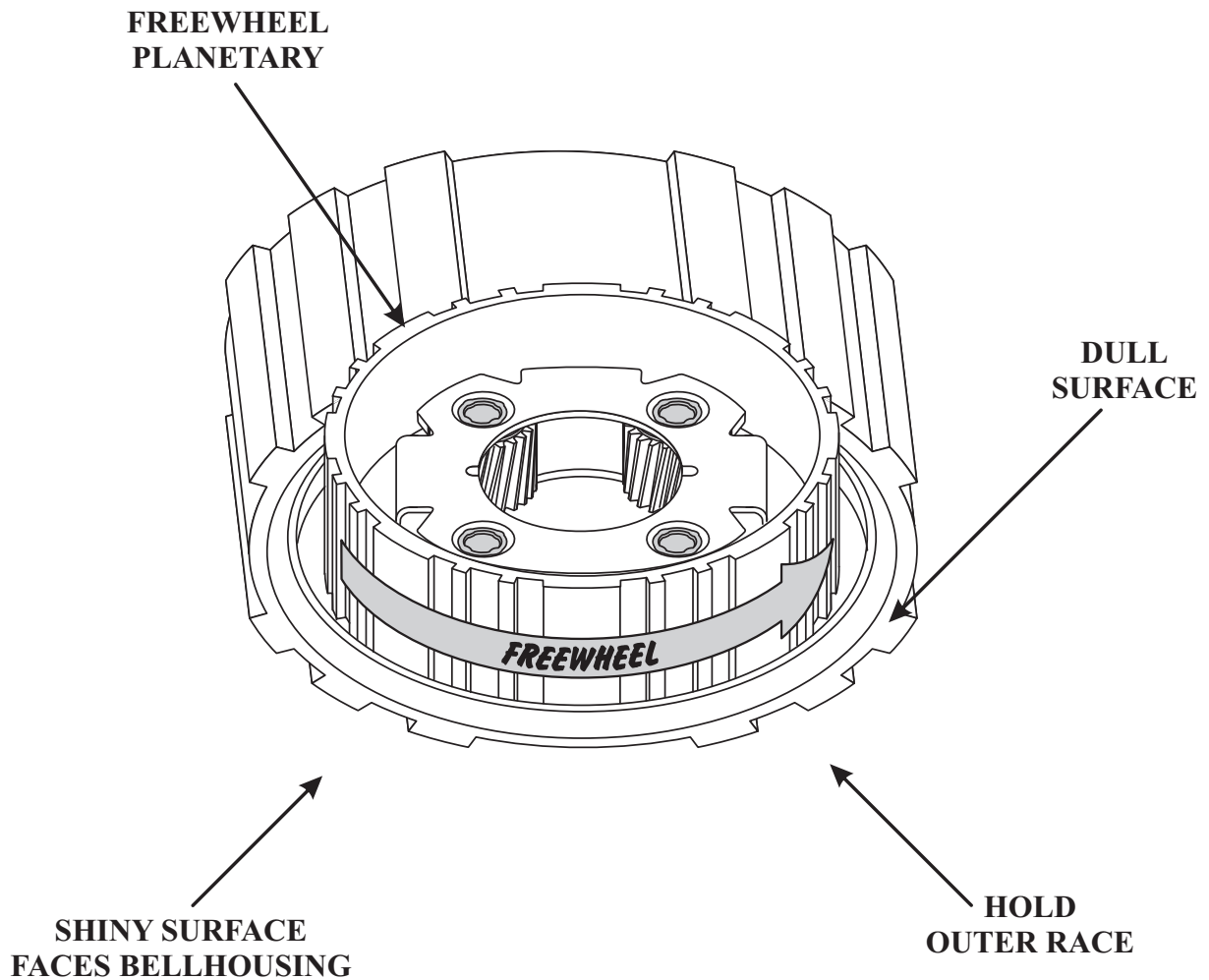

TOYOTA A540 SERIES INTERMEDIATE ONE-WAY CLUTCH

***THE CLUTCH HUB MUST FREEWHEEL CLOCKWISE AND LOCK
COUNTER CLOCKWISE WHEN THE SUN SHELL IS HELD***

**FREEWHEEL
CLUTCH HUB**

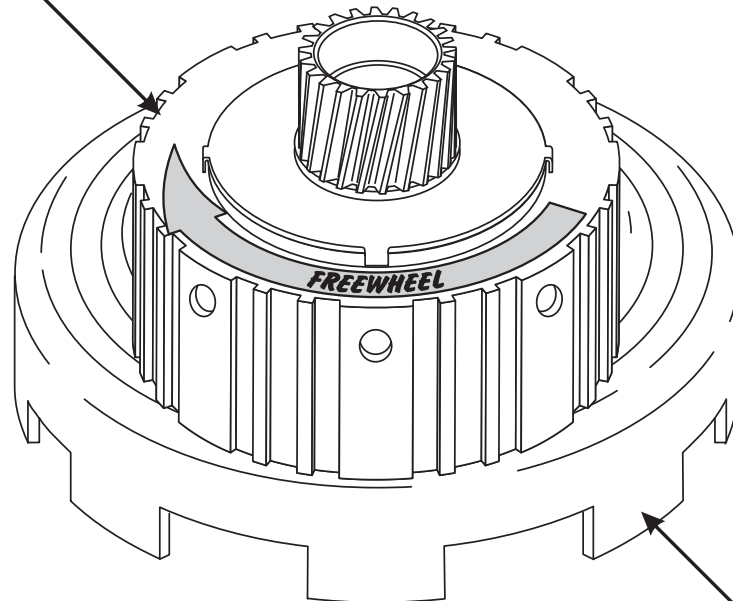

**HOLD
SUN SHELL**



Technical Service Information

TOYOTA A540 SERIES OVERDRIVE ONE-WAY CLUTCH

***THE SHAFT MUST FREEWHEEL CLOCKWISE AND LOCK COUNTER
CLOCKWISE WHEN THE OVERDRIVE DIRECT DRUM IS HELD***

**HOLD
OVERDRIVE
DIRECT DRUM**

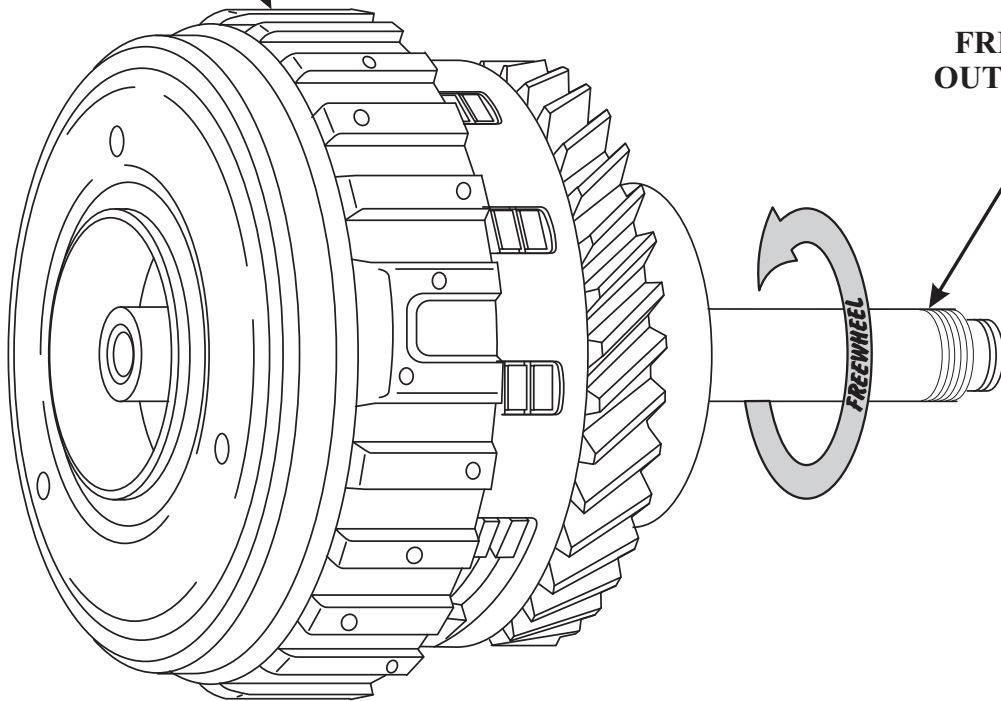

**FREEWHEEL
OUTPUT SHAFT**



Technical Service Information

"UPDATE SECTION"

TOYOTA A540-E TRANSAXLE MODIFICATIONS FOR NEW DESIGN "COMMON SUMP"

CHANGE: Beginning in Mid-May, 1991, many engineering changes were made on all Toyota and Lexus vehicles equipped with the A540-E transaxle, to accommodate a new design "Common Sump" that now allows the transaxle *and* differential to be filled from the transaxle fill tube.

REASON: Increased lubrication performance, and increased final drive durability.

PARTS AFFECTED:

- (1) **TRANSAXLE CASE** - Added passage in transaxle case to allow free flow of oil between the transaxle and the differential. Refer to Figure 2.
Second added passage, near the differential area that is fed with oil from the valve body to keep the differential at a constant oil level. Refer to Figure 2.
A new fitting and tube assembly added on top of the transaxle case to give the transaxle and differential a common vent system. Refer to Figure 1.
Increased thickness in the bellhousing to accommodate 5mm (1/4") increase in the bolts that attach the transaxle to the engine. Refer to Figure 1.
- (2) **TRANSAXLE CASE UPPER COVER** - Added fitting and tube assembly to connect the differential to the transaxles air vent system.
- (3) **DIFFERENTIAL COVER** - Added passage in the cover to transport the oil from the valve body to fill the differential. Refer to Figure 3.
A new design rear engine mount to accommodate the added passage in the differential cover, as shown in Figure 3.
- (4) **VALVE BODY** - Added passage to accommodate a new tube and hold down brackets to supply the differential with fluid, direct from the valve body. Refer to Figure 4.
- (5) **TRANSAXLE DIPSTICK** - The "Full" mark increased from 1.338" to 1.929" on the Lexus vehicles, and from 1.338" to 2.047" on Toyota vehicles, which changes the transaxle and differential fluid capacity. Refer to Figure 5.

INTERCHANGEABILITY:

NONE OF THE PARTS LISTED ABOVE WILL INTERCHANGE WITH PREVIOUS DESIGN LEVEL PARTS. THE NEW DESIGN LEVEL PARTS WILL RETRO-FIT BACK TO PREVIOUS MODEL VEHICLES WHEN ALL OF THE PARTS LISTED ABOVE ARE USED AS A PACKAGE.

TRANSMISSION CASE AND UPPER COVER

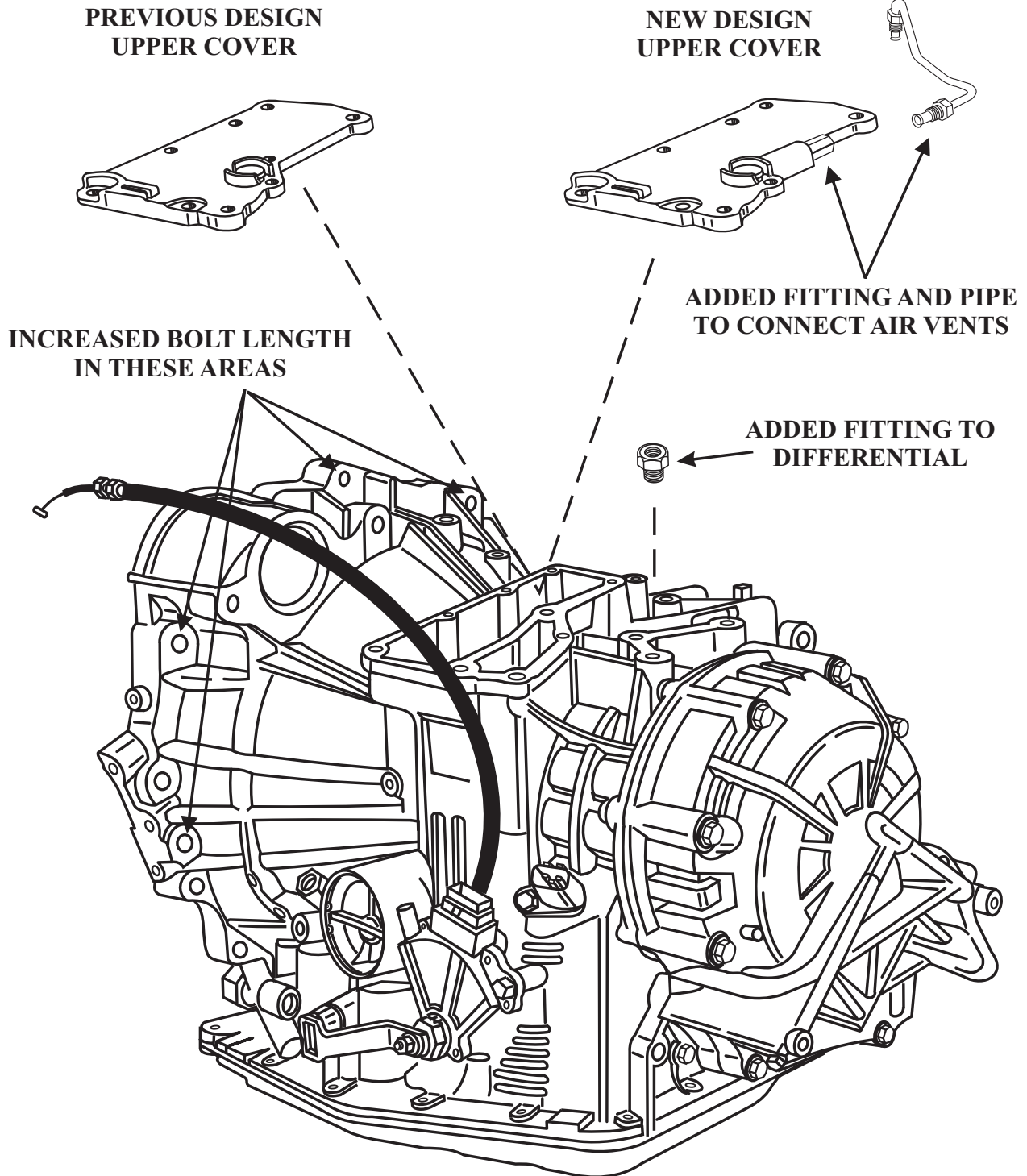
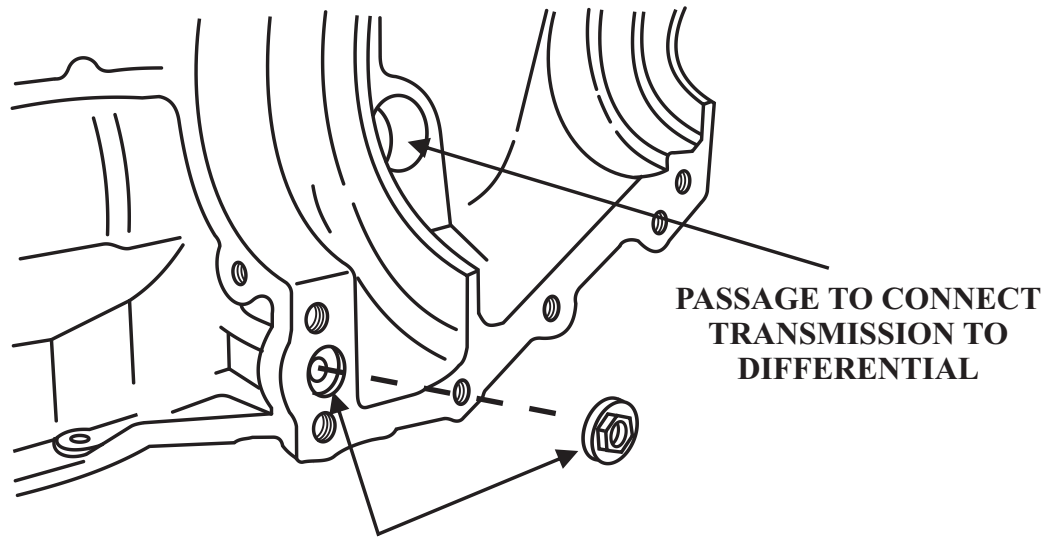

Figure 1
AUTOMATIC TRANSMISSION SERVICE GROUP

DIFFERENTIAL AREA CHANGES



ADDED PASSAGE AND GASKET FOR CONSTANT LEVEL IN DIFFERENTIAL

Figure 2

DIFFERENTIAL COVER CHANGES

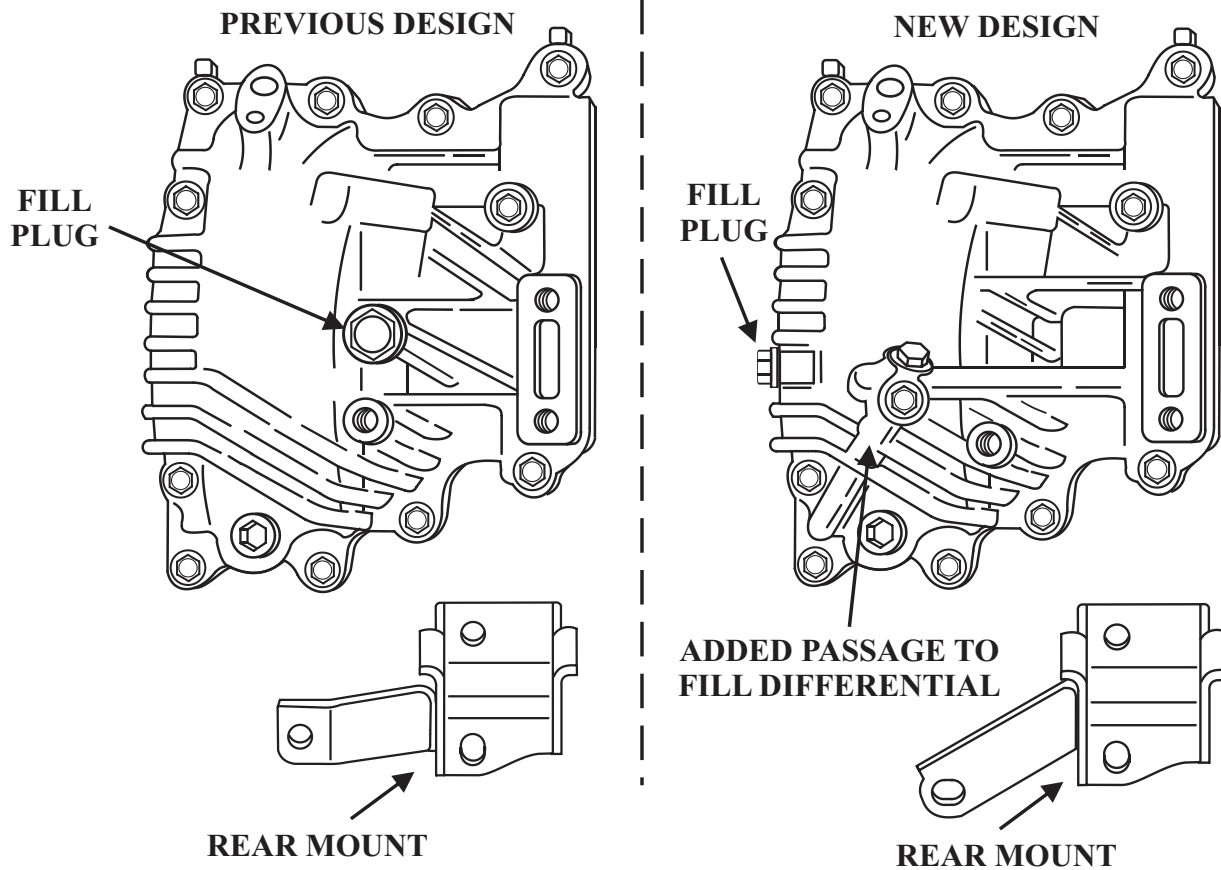

Figure 3

VALVE-BODY

**ADDITIONAL TUBE
AND HOLD DOWN BRACKETS**

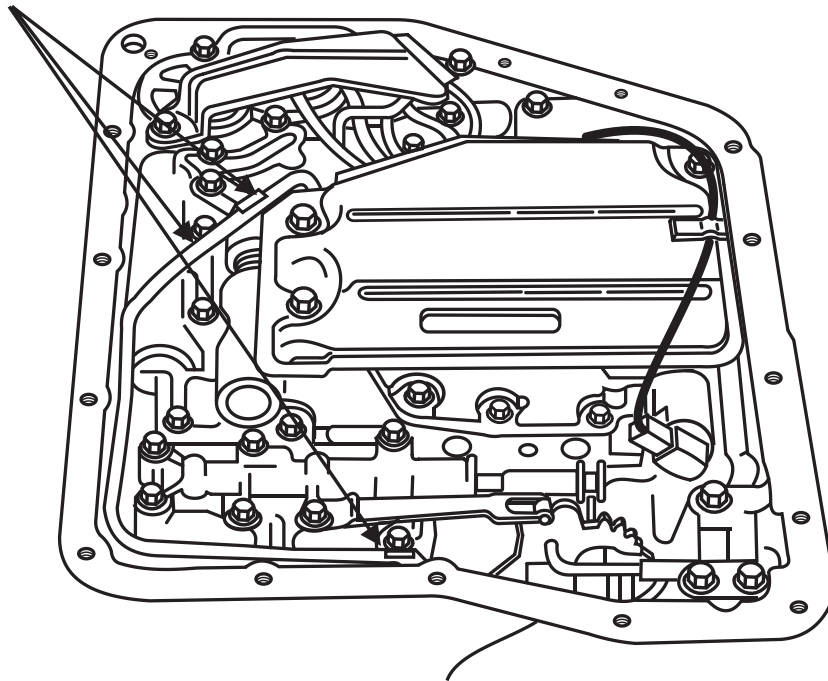
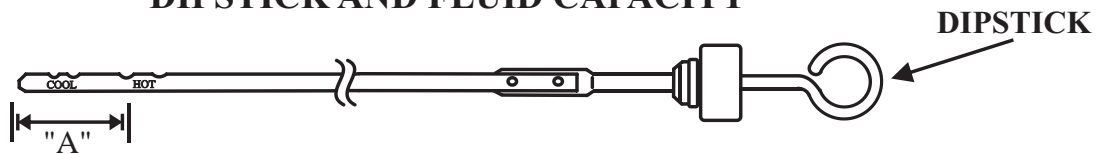

Figure 4

DIPSTICK AND FLUID CAPACITY



DIMENSION "A" = 34mm. (1.338") now 49mm. (1.929") on LEXUS
DIMENSION "A" = 34mm. (1.338") now 52mm. (2.047") on TOYOTA

FLUID CAPACITY'S

	PREVIOUS DESIGN	NEW DESIGN
TRANSMISSION	DRY FILL 6.2 qts. (5.9 liters)	DRY FILL 6.9 qts. (6.5 liters)
	DRAIN & REFILL 2.6 qts. (2.5 liters)	DRAIN & REFILL 3.3 qts. (3.1 liters)
DIFFERENTIAL	DRY FILL 1.1 qts. (1.0 liters)	DRY FILL 0.8 qts. (0.8 liters)
	DRAIN & REFILL 1.1 qts. (1.0 liters)	DRAIN & REFILL 0.8qts. (0.8 liters)

Figure 5



Technical Service Information

TOYOTA 140-E / 540-E HIGH AND/OR LOW LINE PRESSURE

COMPLAINT: Vehicles equipped with 140-E or 540-E transaxles may exhibit insufficient line pressure rise in the Drive ranges and higher than normal pressures in the Reverse range.

CAUSE: The cause may be, the Boost Sleeve in the Pressure Regulator line up severely worn, allowing T.V. pressure to leak into the reverse boost circuit which is open to exhaust at the manual valve, only when the manual valve is in the Drive ranges. When the selector is in the Reverse range, reverse boost oil can now enter the T.V. circuit forcing the Main Regulator valve to create higher than normal pressures.

CORRECTION: Refer to Figure 2 for the location of the boost sleeve in the valve body, and Figure 1 to check the Boost Sleeve for any wear. Replace as necessary with the OEM part numbers listed

SERVICE INFORMATION:

140-E Boost Sleeve (Toyota NO.).....	35417-32010
540-H Boost Sleeve (Toyota NO.).....	35417-32031
540-E Boost Sleeve (Toyota NO.).....	35417-32021

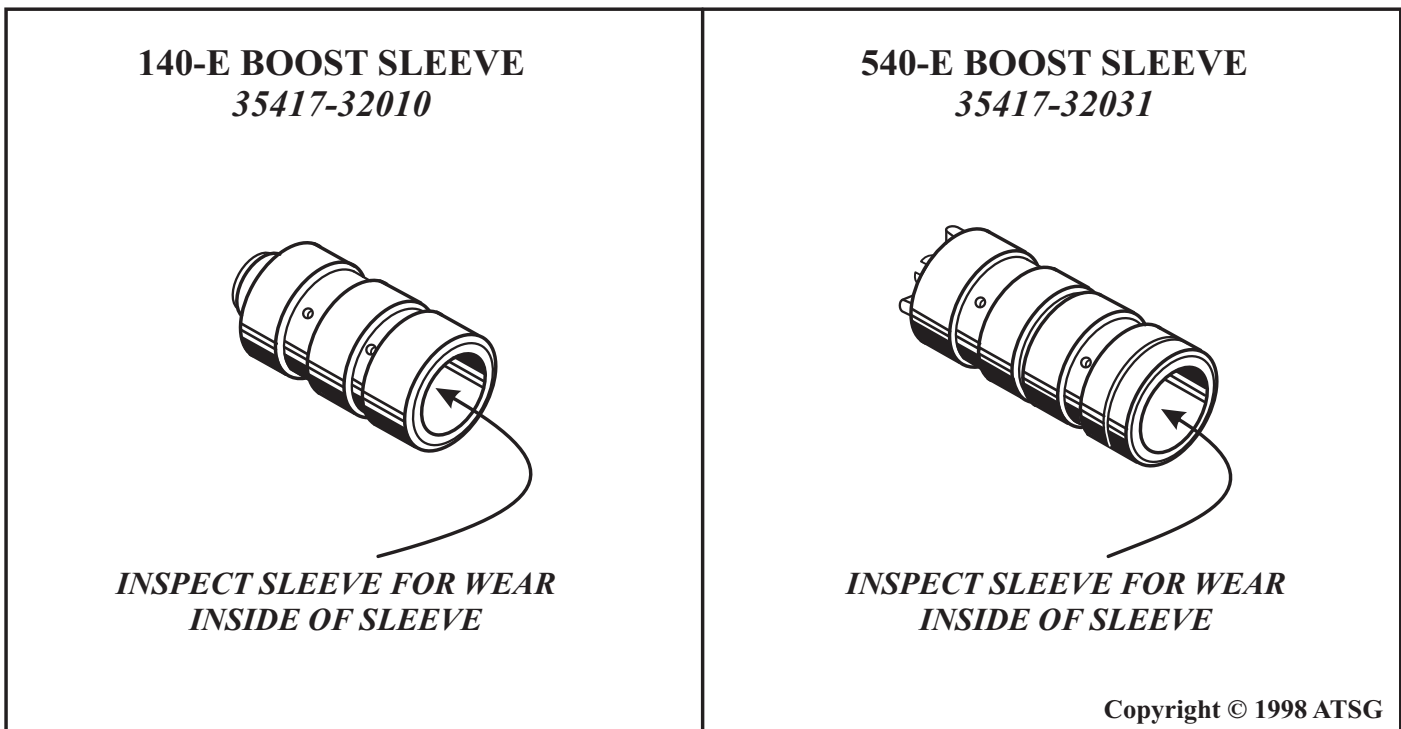
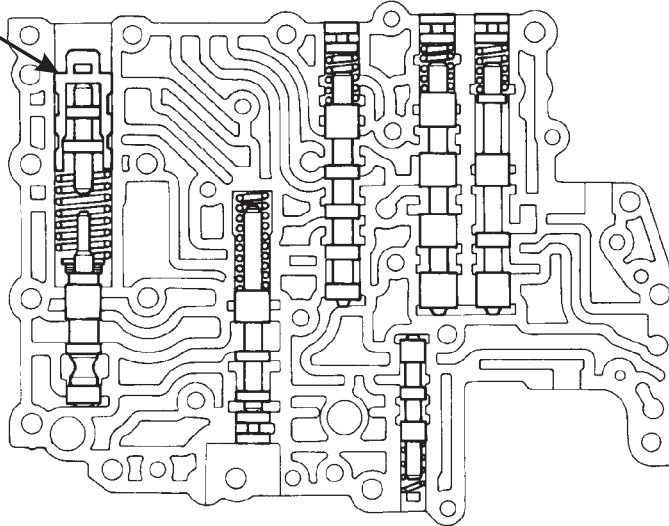

Figure 1

140-E LOWER VALVE BODY

BOOST SLEEVE
LOCATION



540-E LOWER VALVE BODY

BOOST SLEEVE
LOCATION

ADJUSTABLE
STEP

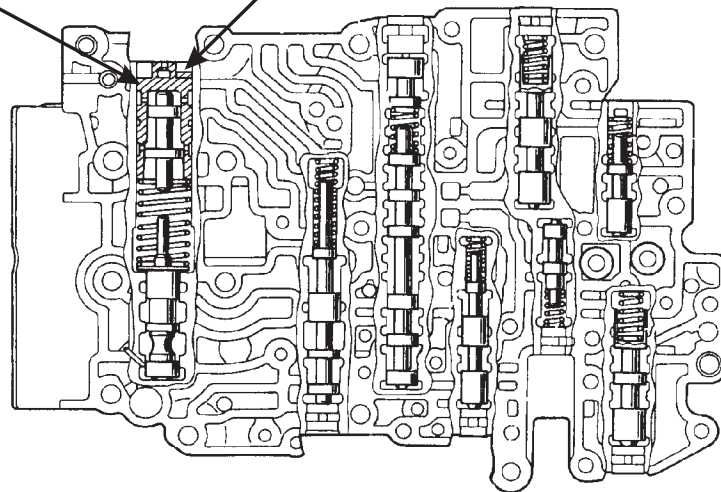

NOTE: THE BOOST SLEEVE ON 540-E HAS AN ADJUSTABLE STEP. ENSURE THAT THE RETAINER IS IN THE SAME LOCATION AS BEFORE.

Copyright © 1998 ATSG

Figure 2